

Product catalogue 2024 for professionals



What's new?

UV Streamer kit – BAEF125AWB



p. 20

- Purifies the air of pollutants such as viruses, bacteria, fine dust, odours, allergens, etc ensuring a healthy and hygienic indoor environment
- Removes 99.9% of viruses in 30 minutes thanks to the Catch and Clean approach
 - Highly efficient ISO ePM1 60% filter (F7)
 - UV light and Streamer technology for cleaning and decomposition of pollutants
- Can be retrofitted into existing installations
- Can be used with BYCQ140E and BYCQ140EW decoration panels

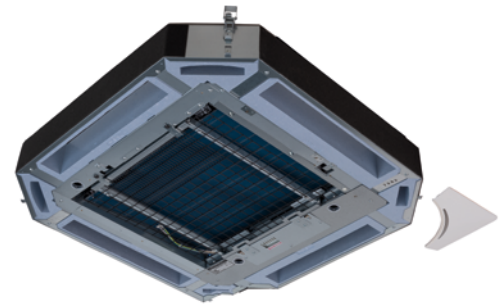

New Sky Air Active-series combinations

p. 49

- AZAS/ARXM outdoor units now also combine with FHA71~140A9 and FVA100~140A
- Ideal solution for busy environments and small shops
- Maximum piping length up to 30m



Biddle air curtains - CYA

p. 58

- Unified model for R-32 and R-410A
- Connectable to VRV and ERQ
- 3 models: F: Free-hanging; C: Cassette and R: Recessed (concealed ceiling)



Daikin Cloud Plus

p. 124

- Remote monitoring and control no matter where you are
- Manage multiple sites and visualize energy consumption with benchmarking
- Remote diagnostics
- Intelligent algorithms predict and prevent failures



Follow energy consumption via Onecta app

p. 110

- You can now easily follow up energy consumption thanks to visualisation of power consumption and heat output



Sky Air

Light commercial applications

What's new?	2
Our sustainability values	5
7 reasons why Sky Air is unique in the market	8
Year-round comfort with air-to-air heat pumps	10
Sky Air Indoor units and air curtains	13
Sky Air Outdoor units	61
Rooftop	87
Commercial Ventilation & Air Purification	94
Control Systems	106
Options & accessories	139
Tools and platforms	151
Technical drawings	157



We're on a mission to build a sustainable legacy

It is in our DNA to provide safe, healthy and comfortable spaces throughout the building life cycle using world-leading technology. Driven by a dedication to achieve net zero CO₂ emissions by 2050, we work together with our partners and customers in helping to create a world with healthier indoor air and minimal environmental impact

Our sustainability values

Supporting decarbonisation

Our solutions are designed to **support your sustainable goals by reducing the CO₂ footprint of buildings**, whether they are new builds or renovation.

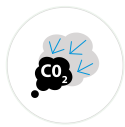

We continuously develop products with lower CO₂ footprint



We maximise real life seasonal efficiency, delivered in a transparent and trustworthy way



We reuse materials where possible, including refrigerants

A collective journey

Together with our partners and customers, we are working towards the sustainable transformation of our buildings. We provide expert **support and peace of mind** throughout the building life cycle, ensuring **future-proof** solutions for a healthier planet.



We help to make the right choice based on the total lifecycle impact of the solutions



Our team of experts provide in-depth knowledge in the use of EPDs, green building schemes, etc.



AI predictive monitoring of our systems, keeps running costs low and maximises uptime

Building for the future

As market leaders in total solutions, we are constantly **innovating to meet your changing needs** and offer you a comfortable, healthy and safe environment.



With our wide range of reliable solutions, our experts can meet even the most complex demands



Making fresh air supply and filtration an integral part of our solution ensures maximum well being



Our solutions are in line with or ahead of legislation, proving you complete peace of mind

Low height.
High value.



Unique, low-height single fan range

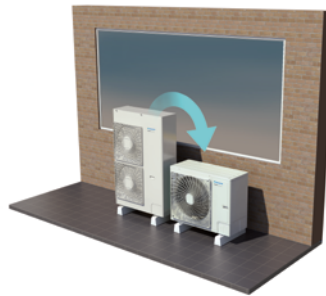

Compact unit, easy to transport

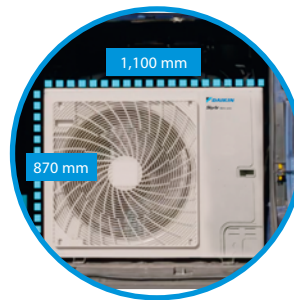

Market-leading serviceability and handling



Fast and easy access to all critical component

- Single screw access
- Wider access area



Newly positioned handle for easier carrying

The smart way for sound reduction

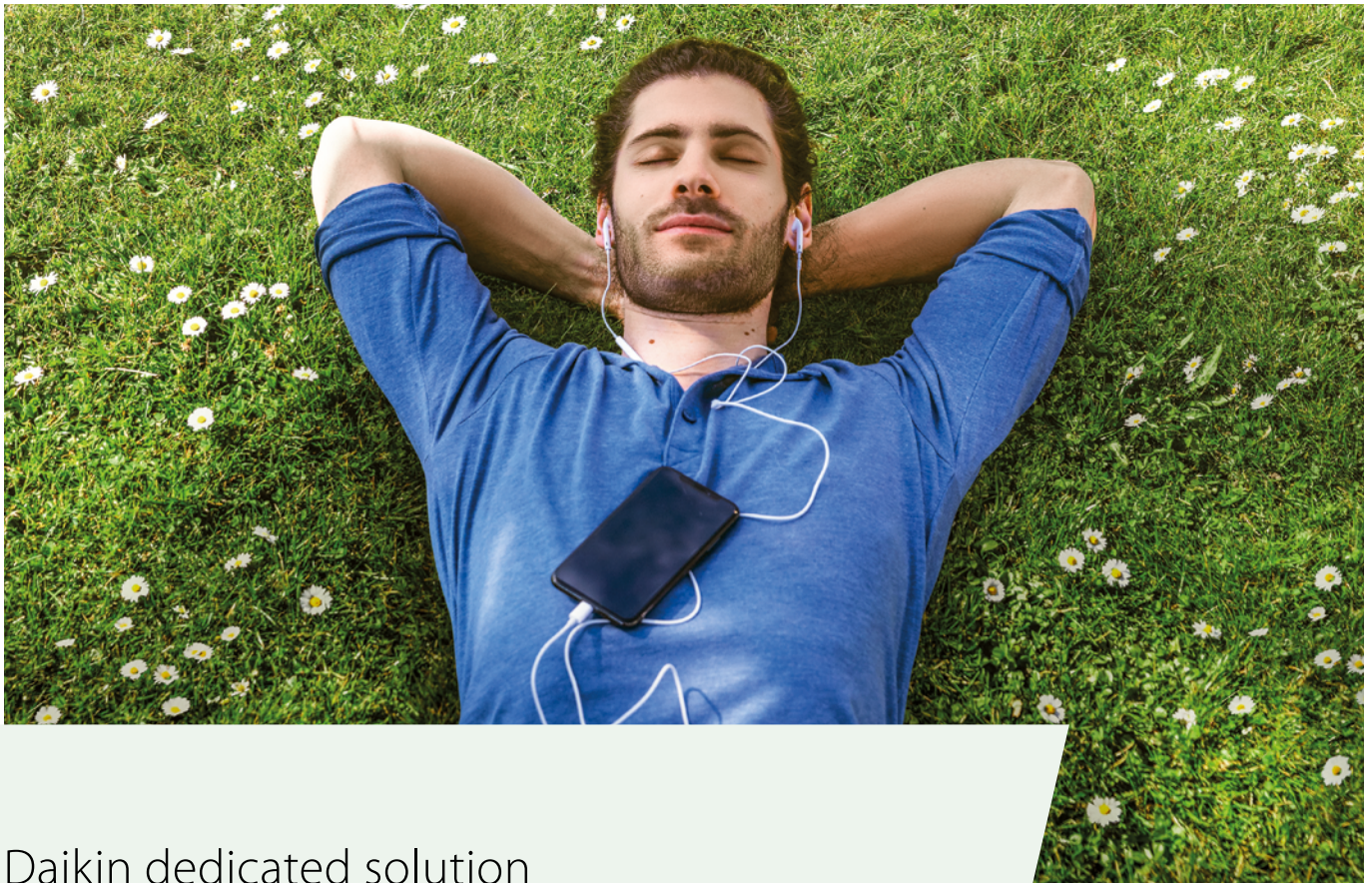

Daikin dedicated solution for sound reduction

Meet strict sound requirements, while increasing flexibility to apply Sky Air and VRV heat pumps thanks to sound power reduction of up to 10 dB(A).

- **Guaranteed high performance:** optimised design to keep the capacity and air flow as close as possible to the standard conditions
- **Faster and reliable planning:** no calculations or estimations necessary thanks to tested data according to ISO 3744
- **Perfect fit:** specially designed for Sky Air and VRV heat pumps
- **Maximum flexibility:** can be installed and retrofitted on any plain surface
- **Easy access:** simple and fast installation and maintenance through large side panels with fast locks
- **Designed to be discreet:** tailor-made low height design; highly aesthetic finishing and smooth surface in anthracite colour-tone



www.daikin.eu/en_us/products/ekln-a.html

SkyAir **VRV**

7 Reasons why sky air is unique in the market

1 Full Sky Air R-32 range delivering future-proofed, best-in-class climate control

SkyAir A-series BLUEEVOLUTION

More details on page 62



System	Type	Model	Product name	35	50	60	71	100	125	140	200	250		
				3.5 kW	5.0 kW	6.0 kW	6.8 kW	9.5 kW	12.1 kW	13.4 kW	21.5 kW	23.6 kW		
Air cooled	Heat pump	SkyAir Alpha-series <ul style="list-style-type: none"> Industry leading technology for commercial applications Dedicated solution for infrastructure cooling Variable Refrigerant Temperature (RZAG71-100-125-140 series) Maximum piping length up to 85m (50m for RZAG35-50-60) Replacement technology Extended operation range down to -20°C in both heating and cooling Pair, twin, triple and double twin application (RZAG71-100-125-140 series) 	R-32 A++ (A+++ - D)	RZAG-A	RZAG-NV1/NY1									
		SkyAir Advance-series <ul style="list-style-type: none"> Technology and comfort combined for commercial applications Very compact and easy to install outdoor units Maximum piping length up to 50m (RZA-D up to 100m) Replacement technology Operation range down to -15°C both cooling and in heating (RZA-D down to -20°C) Pair, twin, triple and double twin application 	R-32 A+ (A+++ - D)	RZASG-MV(1)/MY(1)	RZA-D									
		SkyAir Active-series <ul style="list-style-type: none"> Ideal solution for busy environments and small shops Very compact and easy to install outdoor units Maximum piping length up to 30m Replacement technology Easy-to-mount outdoor units: roof, terrace or wall Exclusively offered for pair applications 	R-32 A (A+++ - D)	ARXM-R	AZAS-MV/MY									

Full indoor line up

(over 45 different models)



2 High energy efficiency

- **Top seasonal efficiency**
 - SEER up to 8.02 and A++ label in cooling and heating
 - Variable Refrigerant Temperature that automatically adapts the refrigerant temperature to the load
- Round flow and concealed ceiling units with **auto cleaning filter**

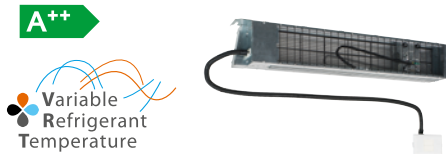

3 Best comfort

- **Variable Refrigerant Temperature** preventing cold draughts
- **Low sound** indoor and outdoor units
- **Presence and floor sensors** direct the air flow away from persons, while ensuring an even temperature distribution
- Operation down to **-20°C in heating and cooling operation**
- **NEW UV Streamer kit**, purifies the air of pollutants such as viruses, bacteria, fine dust (PM1), odours, allergens, etc
- Fresh air intake integrated in indoor unit



4 Top reliability

- For **infrastructure cooling**
 - unique boosted capacity indoor unit systems
 - duty rotation control
- **Refrigerant cooled PCB**
- New refrigerant passes keeping heat exchanger and drain holes completely open at all times
- **Most extensive testing** before new units leave the factory
- **Widest support network** and after sales service
- All spare parts available in Europe



5 Market leading controls

- **Remote connectivity**
 - **Intuitive app control**
 - **Daikin Cloud Plus** offering online control, energy monitoring and comparison of multiple sites
- **User-friendly wired remote controller with premium design**
 - Intuitive touch button control
 - 3 color versions
 - Advanced settings can be easily done via your smartphone
- **Dedicated control solutions**
 - for retail applications
 - for infrastructure cooling



6 Superior aesthetics

- **Fully flat cassette** design unit that integrates fully flat into the ceiling
- **Auto cleaning** units ensure dirt-free ceilings with high efficiency filters for regular and dust prone areas
- Widest ever range cassette panels
 - Available in **white and black**
 - Sleek **designer panel** range





7 Unique installation benefits

- **4-way blow ceiling suspended cassette (FUA)** for rooms without false ceiling.
- Plug & play Daikin air handling unit with ERQ condensing units
- Reliably replace Daikin and non-Daikin systems without the need for pipe cleaning thanks to the new hepta filtration
- Dedicated low sound enclosure, reducing sound power up to -10 dB(A)
- Use up to 4 indoor units linked to one outdoor unit for long or irregularly shaped rooms





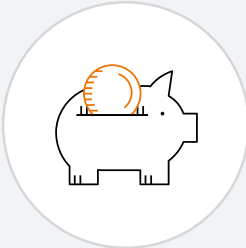
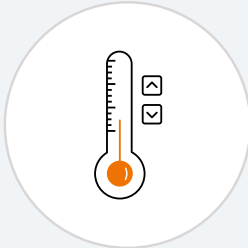
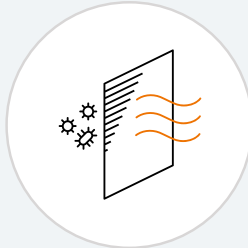





Year-round comfort with air-to-air heat pumps

Get year-round comfort with advanced, efficient, heating and cooling technology.

			
Energy efficient for sustainability and savings	Effortless temperature control, maximum comfort	Optimal indoor air quality	Sleek, elegant design

Designed to suit any space

Having the widest range on the market, Sky Air units will always fit your needs.

  Cassette units <ul style="list-style-type: none">Centrally located for balanced comfortMounted against or in the ceiling, leaving maximum space at the walls	  Concealed ceiling unit <ul style="list-style-type: none">Discreetly concealed in the ceilingOnly the grilles are visible	  Wall mounted <ul style="list-style-type: none">For installation high on the wallIdeal for above indoor installations	  Floor standing <ul style="list-style-type: none">For installation on the groundThis unit can be fit beneath a window
---	---	---	---

Tackle any size of room

Connect up to 4 indoor units on 1 outdoor unit to tackle also larger or irregular shaped rooms. All units are linked to a single control, ensuring an even comfort experience.

Pair solution

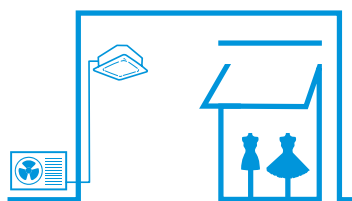



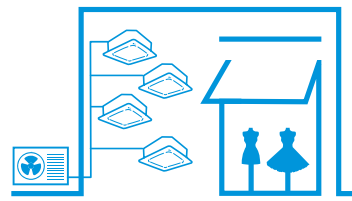

Twin, triple, double twin solution

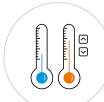

A total building solution

Our Sky Air solution does not only control temperature. Also fresh air ventilation and over-door air curtains keep your indoor space at the highest comfort. All controllable from any place you are and giving in-depth information on energy consumption to optimize energy use.

 Heating and cooling for year round comfort	 Fresh air ventilation for high quality environments	 Controls for maximum operating efficiency	 Air curtains for optimum air separation
---	--	--	--

Typical Sky Air applications

Shops

Reducing retail costs

"Together with Daikin's technical team we have optimised the design of our HVAC system, reducing investment levels and operational costs. Daikin has offered us access to the most up to date technology."
Retail shop representative



youtube.com/
DaikinEurope

Shops



Offices

Efficiency in the workplace

"Leading edge design in harmony with the construction and interior design."
Architect



youtube.com/
DaikinEurope

Office



Hotel

Hospitality with economy

"With Daikin we could perfectly combine the authenticity of the hotel with the latest technology and comfort."
B&B owner



Residential

There is no place like home

"A cost effective, low energy consumption heat pump system for home owners, offering maximum comfort."



Infrastructure cooling

Maximum reliability for IT rooms, laboratories and telecom shelters

"A reliable system and guaranteed continuous operation are what count for me."
General office manager





Sky Air, from high specification, tailored solutions to primary cooling and heating

Indoor Units

Products overview indoor units		14
Benefits overview indoor units		16
Ceiling mounted cassettes		20
▪ UV Streamer kit		20
▪ FCAHG-H	UNIQUE	23
▪ FCAG-B	UNIQUE	24
▪ FFA-A9	UNIQUE	28
Concealed ceiling units		32
▪ Auto cleaning filter for concealed ceiling units	UNIQUE	32
▪ Multi zoning kit		33
▪ FDXM-F9		34
▪ FBA-A(9)		36
▪ FDA125A		40
▪ FDA200-250A		41
▪ ADEA-A		42
Wall mounted units		43
▪ FAA-B		43
▪ FTXM-R		46
Ceiling suspended units		47
▪ FHA-A(9)		47
▪ FUA-A		51
Floor standing units		53
▪ FVA-A		53
Concealed floor standing units		56
▪ FNA-A9		56
Biddle Air curtains		58
▪ CYA-DK-F/C/R		58

Product overview



Type	Model	Product name	PG	
Ceiling mounted cassette	UNIQUE High COP, Round flow cassette	UV Streamer kit FCAHG-H	23	360° air discharge for the highest efficiency and comfort <ul style="list-style-type: none"> High COP cassette ensures top performance for commercial applications Auto cleaning function ensures high efficiency Intelligent sensors save energy and maximize comfort Flexibility to suit every room layout Widest choice ever in decoration panel designs and colors 
	UNIQUE Round flow cassette	UV Streamer kit FCAG-B	24	360° air discharge for the highest efficiency and comfort <ul style="list-style-type: none"> Auto cleaning function ensures high efficiency Intelligent sensors save energy and maximize comfort Flexibility to suit every room layout Lowest installation height in the market Widest choice ever in decoration panel designs and colors 
	UNIQUE Fully flat cassette	FFA-A9	28	Unique design that integrates fully flat into the ceiling <ul style="list-style-type: none"> Perfect integration in standard architectural ceiling tiles Blend of iconic design and engineering excellence Intelligent sensors save energy and maximize comfort Small capacity unit developed for small or well-insulated rooms Flexibility to suit every room layout
Concealed ceiling	Slim concealed ceiling unit	Auto cleaning option Multi zoning option FDXM-F9	34	Slim design for flexible installation <ul style="list-style-type: none"> Compact dimensions enable installation in narrow ceiling voids Medium external static pressure up to 40Pa Small capacity unit developed for small or well-insulated rooms Auto cleaning function ensures high efficiency and reliability
	Concealed ceiling unit with medium ESP	Multi zoning option FBA-A(9)	36	Slimmest yet most powerful medium static pressure unit on the market! <ul style="list-style-type: none"> Slimmest unit in class, only 245mm Low operating sound level Medium external static pressure up to 150Pa facilitates using flexible ducts of varying lengths Automatic air flow adjustment function measures the air volume and static pressure and adjusts it towards the nominal air flow, guaranteeing comfort
	Concealed ceiling unit with high ESP	FDA-A	40	ESP up to 200Pa, ideal for large sized buildings <ul style="list-style-type: none"> Discretely concealed in the ceiling: only the grilles are visible Possibility to change ESP via wired remote control allows optimisation of the supply air volume Flexible installation as the air suction direction can be altered from rear to bottom suction 
		FDA-A	41	ESP up to 250Pa, ideal for extra large sized spaces <ul style="list-style-type: none"> Discretely concealed in the ceiling: only the grilles are visible Possibility to change ESP via wired remote control allows optimisation of the supply air volume 
	Concealed ceiling unit	Multi zoning option ADEA-A	42	Ideal for residential applications with false ceilings <ul style="list-style-type: none"> Energy label up to A Medium external static pressure up to 150Pa facilitates using flexible ducts of varying lengths Slimmest unit in class, only 245mm Exclusively offered for pair applications 
Wall mounted	Wall mounted unit	FAA-B	43	For rooms with no false ceilings nor free floor space <ul style="list-style-type: none"> Flat, stylish front panel The air is comfortably spread up- and downwards thanks to 5 different discharge angles Easy maintenance as this can be done from the front of the unit Flexible to install: pipe connection can be bottom, left or right 
	Perfera wall mounted unit	FTXM-R	46	For rooms with no false ceilings nor free floor space <ul style="list-style-type: none"> Practically inaudible 2 area motion detection sensor Flash streamer technology 3D air flow 
Ceiling suspended	Ceiling suspended unit	FHA-A(9)	47	For wide rooms with no false ceilings nor free floor space <ul style="list-style-type: none"> Ideal for comfortable air flow in wide rooms thanks to Coanda effect Even rooms with ceilings up to 3.8m can be heated up or cooled down very easily! Can be mounted in corners or narrow spaces without any problem 
	UNIQUE 4-way blow ceiling suspended unit	FUA-A	51	Unique Daikin unit for high rooms with no false ceilings nor free floor space <ul style="list-style-type: none"> Rooms with ceilings up to 3.5m can be heated up or cooled down very easily! Can easily be installed in both new and refurbishment projects Intelligent sensors save energy and maximize comfort Flexibility to suit every room layout 
Floor standing	Floor standing unit	FVA-A	53	For spaces with high ceilings <ul style="list-style-type: none"> Ideal solution for commercial spaces with no or narrow false ceilings Even rooms with very high ceilings can be heated up or cooled down very easily! Guarantees a stable temperature Vertical and horizontal outblow 
	Concealed floor standing unit	FNA-A9	56	Designed to be concealed in walls, only grilles remain visible <ul style="list-style-type: none"> Slimmest unit on the market with a depth of only 200mm! Both window sill or ducted installation are possible thanks to sufficient ESP Whisper quiet operation allows installation in any location 

Full R-32 BLUEEVOLUTION line up



























INDOOR UNITS

FULL
single fan
range

Capacity class										Outdoor unit combination						
										R-32						
										SkyAir Alpha-series		SkyAir Advance-series		SkyAir Active-series	SkyAir Active-series	
										RZAG-A	RZAG- NV1/NY1	RZASG- MV(1)/MY(1)	RZA-D	AZAS- MV/MY	ARXM-R	
25	35	50	60	71	100	125	140	200	250							
				•	•	•	•									
	•	•	•	•	•	•	•				✓	✓	✓	✓	✓	✓
•	•	•	•								✓	✓	✓	✓		
•	•	•	•								✓	✓	✓			
	•	•	•	•	•	•	•				✓	✓	✓	✓	✓	✓
						•						✓	✓			
								•	•				✓			
				•	•	•								✓	✓	
				•	•							✓	✓	✓	✓	✓
	•	•	•								✓					
	•	•	•	•	•	•	•				✓	✓	✓	✓	NEW ✓	
				•	•	•						✓	✓	✓		
				•	•	•	•					✓	✓	✓	NEW ✓	
•	•	•	•								✓	✓	✓	✓		

Benefit overview



We care	 Home leave operation	Maintains the indoor temperature at your specified comfort level during absence, thus saving energy.
	 Fan only	The unit can be used as fan, blowing air without heating or cooling.
	 Auto cleaning filter	The filter automatically cleans itself. Simplicity of upkeep means optimum energy efficiency and maximum comfort without the need for expensive or time-consuming maintenance.
	 Presence & floor sensor	The presence sensor directs the air away from any person detected in the room, when the air flow control is on. The floor sensor detects the average floor temperature and ensures an even temperature distribution between ceiling and floor.
Comfort	 Draught prevention	When starting to warm up or when the thermostat is off, the air discharge direction is set horizontally and the fan to low speed, to prevent draught. After warming up, air discharge and fan speed are set as desired.
	 Whisper quiet	Daikin indoor units are whisper quiet. Also the outdoor units are guaranteed not to disturb the quiet of the neighbourhood.
	 Auto cooling-heating changeover	Automatically selects cooling or heating mode to achieve the set temperature.
Air treatment	 NEW UV Streamer kit	Purifies the air of pollutants such as viruses, bacteria, fine dust, odours, allergens, etc ensuring a healthy and hygienic indoor environment
	 Air filter	Removes airborne dust particles to ensure a steady supply of clean air.
Humidity control	 Dry programme	Allows humidity levels to be reduced without variations in room temperature.
Air flow	 Ceiling soiling prevention	Prevents air from blowing out too long in horizontal position, to prevent ceiling stains.
	 Vertical auto swing	Possibility to select automatic vertical moving of the air discharge louvre, for uniform air flow and temperature distribution.
	 Fan speed steps	Allows to select up to the given number of fan speed.
	 Individual flap control	Individual flap control via the wired remote controller enables you to easily fix the position of each flap individually, to suit any new room configuration. Optional closure kits are available as well.
Remote control & timer	 Onecta app	Control your indoor climate from any location via smartphone or tablet.
	 Weekly timer	Can be set to start heating or cooling anytime on a daily or weekly basis.
	 Infrared remote control	Starts, stops and regulates the air conditioner from a distance.
	 Wired remote control	Starts, stops and regulates the air conditioner.
	 Centralised control	Starts, stops and regulates several air conditioners from one central point.
	 Multi zoning	Allows up to 6 individual climate zones with one indoor unit
Other functions	 Infrastructure cooling	Remove in a reliable, efficient and flexible way the heat constantly generated by the IT and server equipment to ensure maximum uptime while offering the best return on investment.
	 Auto-restart	The unit restarts automatically at the original settings after power failure.
	 Self-diagnosis	Simplifies maintenance by indicating system faults or operating anomalies.
	 Drain pump kit	Facilitates condensation draining from the indoor unit.
	 Twin/triple/double twin application	2, 3 or 4 indoor units can be connected to only a single outdoor unit even if they have different capacities. All indoor units operate within the same heating or cooling mode from one remote control.
	 Multi model application	Up to 5 indoor units can be connected to a single outdoor unit, even if they have different capacities. All indoor units can individually be operated within the same heating or cooling mode.
	 VRV for residential application	Up to 9 indoor units (even different capacities and up to 71 class) can be connected to a single outdoor unit. All indoor units can individually be operated within the same mode.

Ceiling mounted cassette units			Concealed ceiling units					Ceiling suspended units	4-Way blow ceiling suspended unit	Wall mounted unit	Perfera wall mounted unit	Floor standing units	
FCAHG-H	FCAG-B	FFA-A9	FDXM-F9	FBA-A(9)	FDA125A	FDA200-250A	ADEA-A	FHA-A(9)	FUA-A	FAA-B	FTXM-R	FVA-A	FNA-A9
●	●	●	●	●	●	●	●	●	●	●	●	●	●
●	●	●	●	●	●	●	●	●	●	●	●	●	●
○	○		○										
○	○	○							○ NEW				
●	●	●							●				
●	●	●		●			●				●		
●	●	●	●	●	●	●	●	●	●	●	●	●	●
○	○												
● (Optional high efficiency filter ePM10 60%)	●	●	●	●	●	●	●	●	●	●	● (Flash streamer; titanium apatite deodorising filter)	●	●
●	●	●	●	●	●	●	●	●	●	●	●	●	●
●	●	●											
●	●	●									● (incl. 3D air flow)	●	
5 + auto	5 + auto	3 + auto	3	3 + auto	9 + auto	3 + auto	3 + auto	5 + auto	3 + auto	3 + auto	5 + auto	3 + auto	3 + auto
●	●	●							●				
○	○	○	○	○	○	○	○	○	○	○	○	○	○
○	○	○	○	○	○	○	○	○	○	○	○	○	○
○	○	○	○	○	○	○	○	○	○	○	●		○
○	○	○	○	○	○	○	○	○	○	○	○	○	○
			○	○			○						
●	●	●	●	●	●	●	●	●	●	●	●	●	●
●	●	●	●	●	●	●	●	●	●	●	●	●	●
●	●	●	●	●	●	●	●	●	●	●	●	●	●
●	●	●	●	●	●	○	●	○	●	○			●
●	●	●	●	●	●	●		●	●	●			●
	●	●	●	●				●					●
	●	●	●	●				●					●

● standard, ○ optional



Fully flat cassette



Concealed ceiling unit

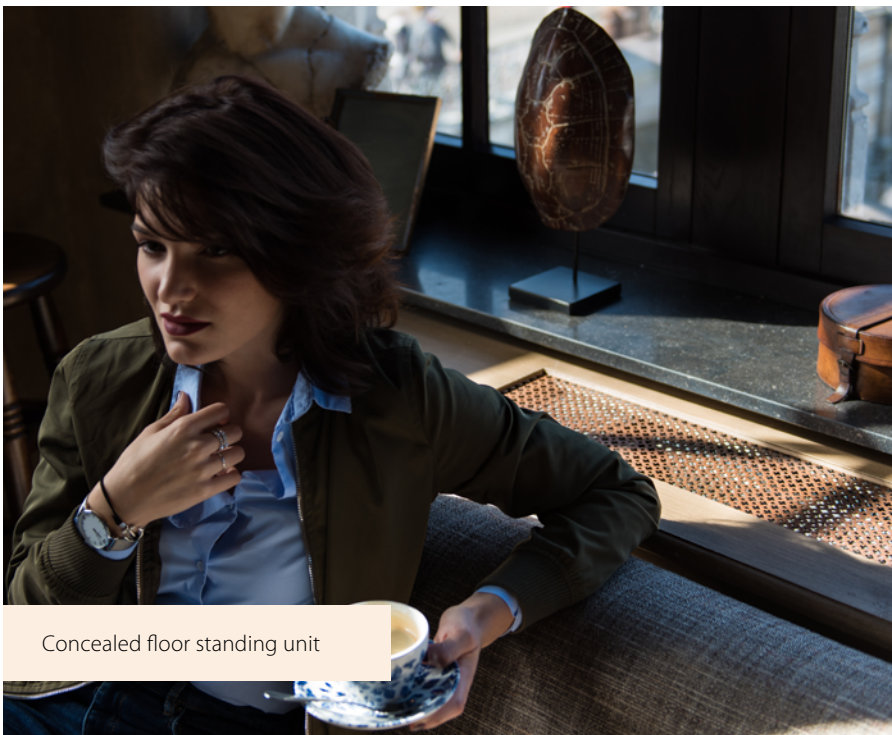

Concealed floor standing unit

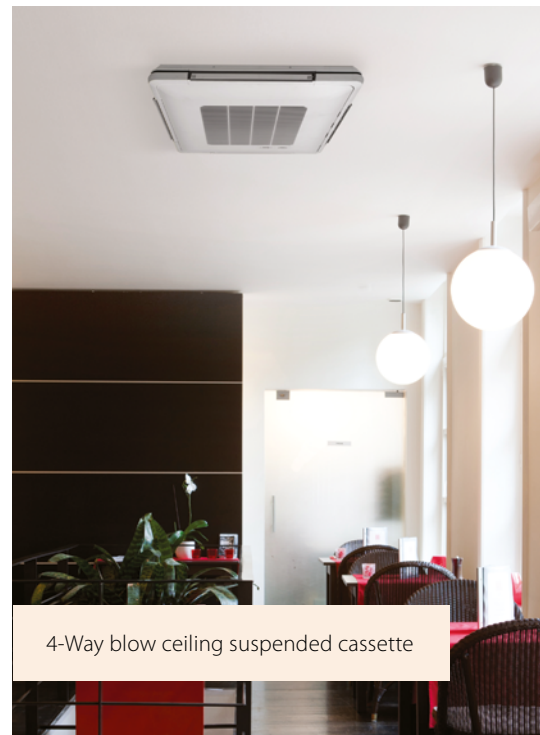

4-Way blow ceiling suspended cassette



Wall mounted unit



Ceiling suspended unit



Round flow cassette, designer panel



Pure air because we care

Breathe healthy air with the round flow UV Streamer kit

90% of our time is spent indoors. However indoor air is 2 to 5 times more polluted than outdoor air.

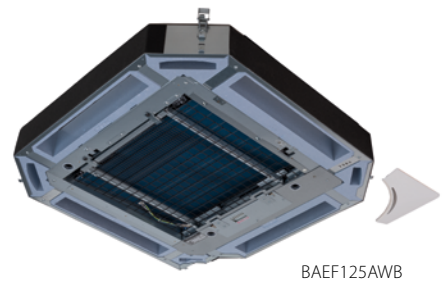

These internal pollution effects on people are manifested in the long run. Tackle them now!

- Our UV streamer kit offers you the solution:
- It purifies the air of pollutants such as viruses, bacteria, fine dust (PM1), odours, allergens, etc ensuring a healthy and hygienic indoor environment
- Unique catch & clean approach includes an ISO ePM1 60% (F7) filter, UV-C light and Streamer technology
- Thanks to large air flow rate of the Round flow cassette, clean air can be quickly delivered to every corner of your space
- Can be retrofitted into existing installations
- Can be used with BYCQ140E and BYCQ140EW decoration panels



99.9%

of viruses removed in 30 minutes, thanks to Daikin's unique

Catch & Clean approach

Tested at Intertek

Results based on tests performed in the laboratories of Intertek, in a 28m³ room. Daikin's Round flow cassette (FXFQ125B) removes more than 99.9% of enveloped viruses such as Corona viruses.

* Additional details regarding this function can be found in the unit technical manual.

Tested according to real life sized room

28m³



View full test report:



Daikin's unique Catch & Clean approach includes an ePM1 50% filter, UV-C light and Streamer technology

1 Effective capturing of air borne pollutants

- Highly efficient capturing particulate matter and pollutants thanks to the ISO ePM1 60% (F7) filter
- Anti bacterial and viral coating

Indicator light

Indicates operation, malfunction or replacement status

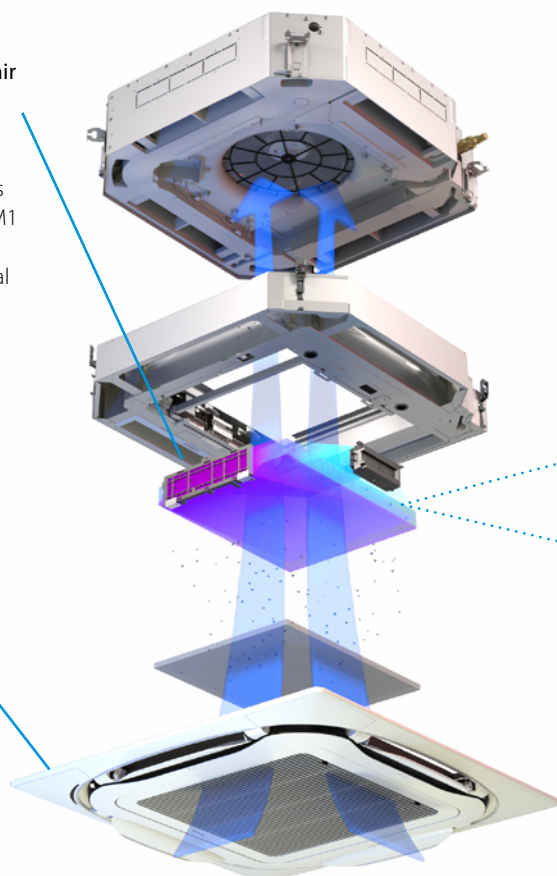

2 Effective cleaning and decomposition of pollutants

Our unique combined UV-C light and Streamer technology ensures both surface and in-depth sanitising of the filter to ensure hygienic air.

UVC LED light with high output wavelength of 265nm which is the most effective for surface cleaning and inactivation of bacteria and viruses.

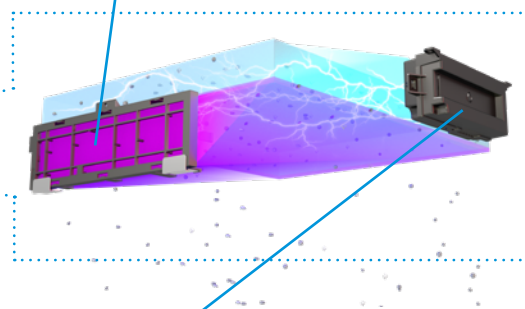

Streamer technology for deep sanitising of the filter and powerful decomposition of viruses and bacteria trapped inside the filter.

Specifications

		BAEF125AWB
Power Supply		1P, 220-240V, 50/60 Hz
Dimensions HxWxD	mm	100 x 840 x 840
Weight	kg	12
Compatible decoration panels		BYCQ140E/BYCQ140EW * (UV-streamer kit cannot be used with other filters, chambers, fresh air intake kits or air discharge outlet sealing member kit)
Filter efficiency		ePM1 60% @ISO16890 (F7)
Replacement interval		Pleated filter (BAF55A125): every year Flash streamer device: every 7 years UV-C LED: every 7 years

* For compatibility with older panels, consult your local sales representative

download the leaflet here



Complete indoor comfort, including pure air

The round flow cassette

- Maximum comfort thanks to **360° air discharge** and intelligent sensors
- **Widest ever choice in panels** to match any interior

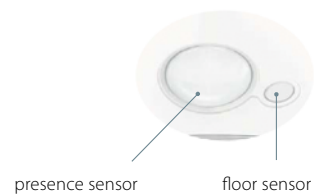

- **Auto cleaning panel** keeps the filter free of dust for maximum efficiency
- **UV streamer kit** **NEW**
 - Purifies the air of pollutants such as viruses, bacteria, fine dust PM1, odours, allergens, etc ensuring a healthy and hygienic indoor environment
 - Unique catch & clean approach includes an ISO ePM1 60% (F7) filter, UV-C light and Streamer technology
 - Can be **retrofitted** into existing installations



99.9%

of viruses removed in 30 minutes,
thanks to Daikin's unique

Catch & Clean approach

Tested at Intertek

Results based on tests performed in the laboratories of Intertek, in a 28m³ room. Daikin's Round flow cassette (FXFQ125B) removes more than 99.9% of enveloped viruses such as Corona viruses.

* Additional details regarding this function can be found in the unit technical manual.

Tested according to
real life sized room

28m³

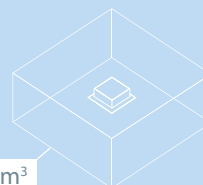

View full
test report:



High COP, round flow cassette

360° air discharge for optimum efficiency and comfort

- Combination with Sky Air Alpha-series ensures best in class quality, highest efficiency and performance
- High COP cassette ensures top performance and great energy savings
- Optional automatic filter cleaning panel results in higher efficiency & comfort and lower maintenance costs.
- Individual flap control: flexibility to suit every room layout without changing the location of the unit!
- Widest choice ever in decoration panels: designer panels in white (RAL9010) and black (RAL9005) and standard panels in white (RAL9010) with grey louvers or full white
- Bigger flaps and unique swing pattern improve equal air distribution
- 5 different fan speeds available for maximum comfort
- UV streamer kit, purifies the air of pollutants such as viruses, bacteria, fine dust, odours, allergens, etc ensuring a healthy and hygienic indoor environment
- Optional fresh air intake
- Branch duct discharge allows to optimize air distribution in irregular shaped rooms or to supply air to small adjacent rooms
- Standard drain pump with 675mm lift increases flexibility and installation speed



FCAHG-H RZAG-NV1 RZAG-NY1

Efficiency data		FCAHG + RZAG									
			71H	100H	125H	140H	71H	100H	125H	140H	
Cooling capacity	Nom.	kW	6.80	9.50	12.1	13.4	6.80	9.50	12.1	13.4	
Heating capacity	Nom.	kW	7.50	10.8	13.5	15.5	7.50	10.8	13.5	15.5	
Space cooling	Energy efficiency class		A++				A++				
	Capacity	Pdesign kW	6.80	9.50	12.1	13.4	6.80	9.50	12.1	13.4	
	SEER		7.90	7.70	8.02	7.93	7.90	7.70	8.02	7.93	
	ηs,c	%	-	-	318	314	-	-	318	314	
Space heating (Average climate)	Annual energy consumption	kWh/a	301	432	905	1,014	301	432	905	1,014	
	Energy efficiency class		A++				A+				
	Capacity	Pdesign kW	4.70	-	9.52	-	4.70	-	9.52	-	
	SCOP/A		4.61	4.75	4.53	4.44	4.56	4.75	4.53	4.44	
ηs,h	%	-	-	178	175	-	-	178	175		
Annual energy consumption	kWh/a	1,427	2,805	2,943	3,002	1,443	2,805	2,943	3,002		
Indoor unit		FCAHG	71H	100H	125H	140H	71H	100H	125H	140H	
Dimensions	Unit	HeightxWidthxDepth	288x840x840								
Weight	Unit		25.0								
Air filter	Type		Resin net								
Decoration panel	Model		Standard panels: BYCQ140E - white with grey louvers / BYCQ140EW - full white / BYCQ140EB - black Auto cleaning panels: BYCQ140EGF - white / BYCQ140EGFB - black Designer panels: BYCQ140EP - white / BYCQ140EPB - black								
	Dimensions	HeightxWidthxDepth	Standard panels: 65x950x950 / Auto cleaning panels: 148x950x950 / Designer panels: 106x950x950								
Fan	Weight		Standard panels: 5.5 / Auto cleaning panels: 10.3 / Designer panels: 6.5								
	Air flow rate	Cooling Low/Medium/High m³/min	13.7/18.8/23.6	19.1/25.7/32.2	21.2/27.3/34.4	13.7/18.8/23.6	19.1/25.7/32.2	21.2/27.3/34.4	13.7/18.8/23.6	19.1/25.7/32.2	
Sound power level	Heating Low/Medium/High m³/min	13.7/18.8/23.6	18.3/24.6/30.8	19.7/25.5/32.1	13.7/18.8/23.6	18.3/24.6/30.8	19.7/25.5/32.1	13.7/18.8/23.6	18.3/24.6/30.8		
	Cooling	dBA	53.0	61.0	53.0	61.0					
Sound pressure level	Heating	dBA	53.0	61.0	53.0	61.0					
	Cooling Low/High	dBA	29.0/36.0	33.0/44.0	35.0/45.0	37.0/45.0	29.0/36.0	33.0/44.0	35.0/45.0	37.0/45.0	
Control systems	Heating Low/High	dBA	29.0/36.0	33.0/44.0	35.0/45.0	37.0/45.0	29.0/36.0	33.0/44.0	35.0/45.0	37.0/45.0	
	Infrared remote control		BRC7FA532F / BRC7FB532F / BRC7FA532FB / BRC7FB532FB								
Power supply	Wired remote control		BRC1H52W/S/K / BRC1E53A / BRC1E53B / BRC1E53C / BRC1D52								
	Phase/Frequency/Voltage	Hz/V	1~/50/60/220-240/220								
Piping connections	Drain		VP25 (I.D. 25/O.D. 32)								
Outdoor unit		RZAG	71NV1	100NV1	125NV1	140NV1	71NY1	100NY1	125NY1	140NY1	
Dimensions	Unit	HeightxWidthxDepth	870x1,100x460								
Weight	Unit		81	85	95	81	85	94			
Sound power level	Cooling	dBA	64	66	69	70	64	66	69	70	
	Heating	dBA	-	-	68	71	-	-	68	71	
Sound pressure level	Cooling Nom.	dBA	46	47	49	50	46	47	49	50	
	Heating Nom.	dBA	48	50	52	48	50	52			
Operation range	Cooling Ambient Min.~Max.	°CDB	-20~-52								
	Heating Ambient Min.~Max.	°CWB	-20~-18								
Refrigerant	Type/GWP		R-32/675								
	Charge	kg/TCO2Eq	3.20/2.16		3.70/2.50		3.20/2.16		3.70/2.50		
Piping connections	Liquid/Gas OD	mm	9.52/15.9								
	Piping length	OU - IU Max. m	55	85	55	85					
	System Equivalent Chargeless	m	75	100	75	100					
	Level difference IU - OU Max.	m	40								
Power supply	Additional refrigerant charge	kg/m	30								
	Phase/Frequency/Voltage	Hz/V	1~/50 /220-240				See installation manual				
Current - 50Hz	Maximum fuse amps (MFA)	A	20	32	16						

Contains fluorinated greenhouse gases



Round flow cassette

360° air discharge for optimum efficiency and comfort

- Combination with Sky Air Alpha-series ensures best in class quality, highest efficiency and performance
- Optional automatic filter cleaning panel results in higher efficiency & comfort and lower maintenance costs
- Two optional intelligent sensors improve energy efficiency and comfort
- Individual flap control: flexibility to suit every room layout without changing the location of the unit!
- Lowest installation height in the market: 214mm for class 20-63
- Widest choice ever in decoration panels: designer panels in white (RAL9010) and black (RAL9005) and standard panels in white (RAL9010) with grey louvers or full white
- Bigger flaps and unique swing pattern improve equal air distribution
- UV streamer kit, purifies the air of pollutants such as viruses, bacteria, fine dust, odours, allergens, etc ensuring a healthy and hygienic indoor environment
- Optional fresh air intake
- Branch duct discharge allows to optimize air distribution in irregular shaped rooms or to supply air to small adjacent rooms
- Standard drain pump with 675mm lift increases flexibility and installation speed



- Floor and presence sensor
- Home leave operation
- Auto cleaning filter
- Draught prevention
- Individual flap control

		FCAG-B				RZAG-A				RZAG-NV1				RZAG-NY1				
Efficiency data		FCAG + RZAG		35B	+ 35A	50B	+ 50A	60B	+ 60A	71B	+ 71NV1	100B	+ 100NV1	125B	+ 125NV1	140B	+ 140NY1	
Cooling capacity	Nom.	kW		1.6/3.5/4.5	1.7/5.0/6.0	1.7/6.0/6.5	-/6.80/-	-/9.50/-	-/12.1/-	-/13.4/-	-/6.80/-	-/9.50/-	-/12.1/-	-/13.4/-	-/13.4/-	-/13.4/-	-/13.4/-	
Heating capacity	Nom./Max.	kW		1.40/4.00/5.00	1.50/5.80/6.00	1.60/7.00/7.50	-/7.50/-	-/10.8/-	-/13.5/-	-/15.5/-	-/7.50/-	-/10.8/-	-/13.5/-	-/15.5/-	-/15.5/-	-/15.5/-	-/15.5/-	
Space cooling	Energy efficiency class			A++				-				A++						
	Capacity	Pdesign	kW	3.50	5.00	6.00	6.80	9.50	12.1	13.4	6.80	9.50	12.1	13.4	13.4	13.4	13.4	
	SEER			7.30	6.80	6.60	6.83	7.14	7.15	6.80	6.83	7.14	7.15	6.80	6.83	7.15	6.80	
	ηs,c		%	-	-	-	-	-	283	269	-	-	283	269	-	283	269	
Space heating (Average climate)	Energy efficiency class			A+				-				A+						
	Capacity	Pdesign	kW	3.30	4.30	4.60	4.70	7.80	9.52	4.70	7.80	9.52	4.70	7.80	9.52	4.70	7.80	
	SCOP/A			4.30	4.25	4.22	4.53	4.53	4.34	4.22	4.53	4.34	4.22	4.53	4.34	4.34	4.34	
	ηs,h		%	-	-	-	-	-	171	-	-	171	-	-	171	-	171	
Annual energy consumption		kWh/a	1,074	1,398	1,515	1,560	2,413	3,071	1,560	2,413	3,071	1,560	2,413	3,071	1,560	2,413	3,071	
Indoor unit		FCAG		35B	50B	60B	71B	100B	125B	140B	71B	100B	125B	140B				
Dimensions	Unit	HeightxWidthxDp	mm	204x840x840				246x840x840				204x840x840				246x840x840		
Weight	Unit		kg	18	19		21		23		21		23					
Air filter	Type			Resin net														
Decoration panel	Model			Standard panels: BYCQ140E - white with grey louvers / BYCQ140EW - full white / BYCQ140EB - black Auto cleaning panels: BYCQ140EGF - white / BYCQ140EGFB - black Designer panels: BYCQ140EP - white / BYCQ140EPB - black														
	Dimensions	HeightxWidthxDp	mm	Standard panels: 65x950x950 / Auto cleaning panels: 148x950x950 / Designer panels: 106x950x950														
	Weight		kg	Standard panels: 5.5 / Auto cleaning panels: 10.3 / Designer panels: 6.5														
Fan	Air flow rate	Cooling	Low/Medium/High	m ³ /min	8.8/10.6/12.9	9.4/11.8/14.6	9.6/12.2/14.9	10.8/13.0/15.1	13.0/17.8/22.7	13.1/20.4/27.2	10.8/13.0/15.1	13.0/17.8/22.7	13.1/20.4/27.2	9.4/11.6/14.1	9.4/11.8/14.6	9.6/12.2/14.9	10.8/12.9/15.1	13.2/18.1/23.0
	Heating	Low/Medium/High	m ³ /min	9.4/11.6/14.1	9.4/11.8/14.6	9.6/12.2/14.9	10.8/12.9/15.1	13.2/18.1/23.0	13.0/20.2/27.0	10.8/12.9/15.1	13.2/18.1/23.0	13.0/20.2/27.0	9.4/11.6/14.1	9.4/11.8/14.6	9.6/12.2/14.9	10.8/12.9/15.1	13.2/18.1/23.0	13.0/20.2/27.0
Sound power level	Cooling		dB(A)	49.0		51.0		54.0		58.0		51.0		54.0		58.0		51.0
	Heating		dB(A)	49.0		51.0		54.0		58.0		51.0		54.0		58.0		51.0
Sound pressure level	Cooling	Low/High	dB(A)	27.0/31.0		28.0/33.0		28.0/35.0		29.0/37.0		28.0/35.0		29.0/37.0		29.0/41.0		28.0/35.0
	Heating	Low/High	dB(A)	27.0/31.0		28.0/33.0		29.0/37.0		29.0/41.0		28.0/33.0		29.0/37.0		29.0/41.0		29.0/41.0
Control systems	Infrared remote control			BRC7FA532F / BRC7FB532F / BRC7FA532FB / BRC7FB532FB														
	Wired remote control			BRC1H52W/S/K / BRC1E53A / BRC1E53B / BRC1E53C / BRC1D52														
Power supply	Phase/Frequency/Voltage		Hz/V	1~/50/60/220-240/220														
Piping connections	Drain			VP25 (O.D. 32 / I.D. 25)														
Outdoor unit		RZAG		35A	50A	60A	71NV1	100NV1	125NV1	140NV1	71NY1	100NY1	125NY1	140NY1				
Dimensions	Unit	HeightxWidthxDp	mm	734x870x373				870x1,100x460										
Weight	Unit		kg	52				81	85	95		81	85	94				
Sound power level	Cooling		dB(A)	62.0	63.0	64.0	64	66	69	70	64	66	69	70				
	Heating		dB(A)	62.0	63.0	64.0			68	71			68	71				
Sound pressure level	Cooling	Nom.	dB(A)	48.0	49.0	50.0	46	47	49	50	46	47	49	50				
	Heating	Nom.	dB(A)	48.0	49.0	50.0	48	50		52	48	50		52				
Operation range	Cooling	Ambient	Min.~Max.	-20~-52				-20~-52										
	Heating	Ambient	Min.~Max.	-20~-24				-20~-18										
Refrigerant	Type/GWP			R-32/675.0														
	Charge	kg/TCO2Eq		1.55/1.05				3.20/2.16		3.70/2.50		3.20/2.16		3.70/2.50				
Piping connections	Liquid/Gas OD		mm	6.35/9.52		6.35/12.7		9.52/15.9										
	Piping length	OU - IU	m	50				55		85		55		85				
	System	Equivalent	m	-				75		100		75		100				
	Chargeless		m	30				40										
	Level difference	IU - OU	Max.	m	30.0				30									
Additional refrigerant charge		kg/m		0.02 (for piping length exceeding 30m)														
Power supply	Phase/Frequency/Voltage		Hz/V	1~/50 / 220-240														
Current - 50Hz	Maximum fuse amps (MFA)		A	-				20		32		3~/50 / 380-415				16		

Contains fluorinated greenhouse gases

Round flow cassette

360° air discharge for optimum efficiency and comfort

- Combination with Sky Air Advance-series ensures good value for money for all types of commercial applications
- Optional automatic filter cleaning panel results in higher efficiency & comfort and lower maintenance costs.
- Two optional intelligent sensors improve energy efficiency and comfort
- Widest choice ever in decoration panels: designer panels in white (RAL9010) and black (RAL9005) and standard panels in white (RAL9010) with grey louvers or full white
- Bigger flaps and unique swing pattern improve equal air distribution
- Individual flap control: flexibility to suit every room layout without changing the location of the unit!
- UV streamer kit, purifies the air of pollutants such as viruses, bacteria, fine dust, odours, allergens, etc ensuring a healthy and hygienic indoor environment
- Optional fresh air intake
- Branch duct discharge allows to optimize air distribution in irregular shaped rooms or to supply air to small adjacent rooms
- Standard drain pump with 675mm lift increases flexibility and installation speed



FCAG-B		RZASG-MV1		RZASG-MY1		RZASG-MV		RZASG-MY			
Efficiency data		FCAG + RZASG		71B + 71MV1	100B + 100MV(1)	125B + 125MV(1)	140B + 140MV(1)	100B + 100MY(1)	125B + 125MY(1)	140B + 140MY(1)	
Cooling capacity	Nom.	kW		6.80	9.50	12.1	13.4	9.50	12.1	13.4	
Heating capacity	Nom.	kW		7.50	10.8	13.5	15.5	10.8	13.5	15.5	
Space cooling	Energy efficiency class		A++		-		A++		-		
	Capacity	Pdesign	kW		6.80	9.50	12.1	13.4	9.50	12.1	13.4
	SEER		6.47		6.55	5.76	6.53	6.55	5.76	6.53	
	ηs,c		%		-	227	258	-	227	258	
Annual energy consumption		kWh/a		368	507	1,261	1,231	507	1,261	1,231	
Space heating (Average climate)	Energy efficiency class		A+		-		A+		-		
	Capacity	Pdesign	kW		4.50	6.00	7.80	6.00	7.80		
	SCOP/A		4.10		4.17	4.05	4.31	4.17	4.05	4.31	
	ηs,h		%		-	159	169	-	159	169	
Annual energy consumption		kWh/a		1,537	2,016	2,074	2,534	2,016	2,074	2,534	
Indoor unit		FCAG		71B	100B	125B	140B	100B	125B	140B	
Dimensions	Unit	HeightxWidthxDepth		mm		204x840x840		246x840x840			
Weight	Unit	kg		21		23		23			
Air filter	Type	Resin net									
Decoration panel	Model	Standard panels: BYCQ140E - white with grey louvers / BYCQ140EW - full white / BYCQ140EB - black Auto cleaning panels: BYCQ140EGF - white / BYCQ140EGFB - black Designer panels: BYCQ140EP - white / BYCQ140EPB - black									
Fan	Dimensions		HeightxWidthxDepth		mm		Standard panels: 65x950x950 / Auto cleaning panels: 148x950x950 / Designer panels: 106x950x950				
	Weight		kg		Standard panels: 5.5 / Auto cleaning panels: 10.3 / Designer panels: 6.5						
Sound power level	Air flow rate	Cooling	Low/Medium/High	m³/min	10.8/13.0/15.1	13.0/17.8/22.7	13.1/20.4/27.2	13.0/17.8/22.7	13.1/20.4/27.2		
	Heating	Low/Medium/High	m³/min	10.8/12.9/15.1	13.2/18.1/23.0	13.0/20.2/27.0	13.2/18.1/23.0	13.0/20.2/27.0			
Sound pressure level	Cooling	dBA		51.0	54.0	58.0	54.0	58.0			
	Heating	dBA		51.0	54.0	58.0	54.0	58.0			
Sound pressure level	Cooling	Low/Medium/High	dBA	28.0/31.0/35.0	29.0/33.0/37.0	29.0/35.0/41.0	29.0/33.0/37.0	29.0/35.0/41.0			
	Heating	Low/Medium/High	dBA	28.0/31.0/33.0	29.0/33.0/37.0	29.0/35.0/41.0	29.0/33.0/37.0	29.0/35.0/41.0			
Control systems	Infrared remote control		BRC7FA532F / BRC7FB532F / BRC7FA532FB / BRC7FB532FB								
Wired remote control		BRC1H52W/S/K / BRC1E53A / BRC1E53B / BRC1E53C / BRC1D52									
Power supply	Phase/Frequency/Voltage		Hz/V		1~/50/60/220-240/220						
Outdoor unit		RZASG		71MV1	100MV(1)	125MV(1)	140MV(1)	100MY(1)	125MY(1)	140MY(1)	
Dimensions	Unit	HeightxWidthxDepth		mm		770x900x320		990x940x320			
Weight	Unit	kg		60		70 (MV1) / 72 (MV)		78 (MV1) / 79 (MV)		70 (MY1) / 72 (MY)	
Sound power level	Cooling	dBA		65		70		73		71	
	Heating	dBA		-		71		73		71	
Sound pressure level	Cooling	Nom.	dBA	46		53		54		53	
	Heating	Nom.	dBA	47		-		57		54	
Operation range	Cooling	Ambient	Min.~Max.	°CDB		-15~46					
	Heating	Ambient	Min.~Max.	°CWB		-15~-15.5					
Refrigerant	Type/GWP		R-32/675								
Piping connections	Charge	kg/TCO2Eq		2.45/1.65		2.60/1.76		2.90/1.96		2.60/1.76	
	Liquid/Gas OD	mm		9.52/15.9							
Piping connections	Piping length	OU - IU	Max.	m		50					
	System	Equivalent	Chargeless	m		70					
	Additional refrigerant charge		kg/m		See installation manual						
	Level difference IU - OU		Max.		m		30.0				
Power supply	Phase/Frequency/Voltage		Hz/V		1~/50 / 220-240		3~/50 / 380-415				
Current - 50Hz	Maximum fuse amps (MFA)		A		20		25		32		
										16	

Contains fluorinated greenhouse gases



Round flow cassette

360° air discharge for optimum efficiency and comfort

- Ideal solution for small businesses and shops
- Optional automatic filter cleaning panel results in higher efficiency & comfort and lower maintenance costs.
- Two optional intelligent sensors improve energy efficiency and comfort
- Widest choice ever in decoration panels: designer panels in white (RAL9010) and black (RAL9005) and standard panels in white (RAL9010) with grey louvers or full white
- Individual flap control: flexibility to suit every room layout without changing the location of the unit!
- Bigger flaps and unique swing pattern improve equal air distribution
- UV streamer kit, purifies the air of pollutants such as viruses, bacteria, fine dust, odours, allergens, etc ensuring a healthy and hygienic indoor environment
- Optional fresh air intake
- Branch duct discharge allows to optimize air distribution in irregular shaped rooms or to supply air to small adjacent rooms
- Standard drain pump with 675mm lift increases flexibility and installation speed



		FCAG-B		ARXM-R		AZAS-MV		AZAS-MY			
Efficiency data		FCAG + ARXM / AZAS		71B + ARXM 71R	100B + AZAS100MV	125B + AZAS125MV	140B + AZAS140MV	100B + AZAS100MY	125B + AZAS125MY	140B + AZAS140MY	
Cooling capacity	Nom.	kW		6.80/7.05	9.50/-	12.1/-	13.4/-	9.50/-	12.1/-	13.4/-	
Heating capacity	Nom./Max.	kW		7.50/7.58	10.8/-	13.5/-	15.5/-	10.8/-	13.5/-	15.5/-	
Space cooling	Energy efficiency class			A+		-		A+		-	
	Capacity	Pdesign	kW	6.80	9.50	12.1	13.0	9.50	12.1	13.0	
	SEER			5.87	6.1	5.6	6.2	6.1	5.6	6.2	
	ηs,c		%	-	-	221	245	-	221	245	
	Annual energy consumption	kWh/a		405	586	1,345	1,300	586	1,345	1,300	
Space heating (Average climate)	Energy efficiency class			A		-		A		-	
	Capacity	Pdesign	kW	4.50	6.00	7.80	7.80	6.00	6.00	7.80	
	SCOP/A			4.00	3.85	3.80	4.31	3.85	3.80	4.31	
	ηs,h		%	-	-	149	169	-	149	169	
	Annual energy consumption	kWh/a		1,573	2,182	2,211	2,534	2,182	2,211	2,534	
Indoor unit		FCAG		71B	100B	125B	140B	100B	125B	140B	
Dimensions	Unit	HeightxWidthxDepth	mm	204x840x840		246x840x840					
Weight	Unit		kg	21	23						
Air filter	Type			Resin net							
Decoration panel	Model			Standard panels: BYCQ140E - white with grey louvers / BYCQ140EW - full white / BYCQ140EB - black Auto cleaning panels: BYCQ140EGF - white / BYCQ140EGFB - black Designer panels: BYCQ140EP - white / BYCQ140EPB - black							
		Dimensions	HeightxWidthxDepth	mm	Standard panels: 65x950x950 / Auto cleaning panels: 148x950x950 / Designer panels: 106x950x950						
		Weight	kg	Standard panels: 5.5 / Auto cleaning panels: 10.3 / Designer panels: 6.5							
Fan	Air flow rate	Cooling	Low/Medium/High	m³/min	10.8/13.0/15.1	13.0/17.8/22.7	13.1/20.4/27.2	13.0/17.8/22.7	13.1/20.4/27.2	13.0/17.8/22.7	
		Heating	Low/Medium/High	m³/min	10.8/12.9/15.1	13.2/18.1/23.0	13.0/20.2/27.0	13.2/18.1/23.0	13.0/20.2/27.0	13.2/18.1/23.0	
Sound power level	Cooling			dBA	51.0	54.0	58.0	54.0	58.0	58.0	
	Heating			dBA	51.0	54.0	58.0	54.0	58.0	58.0	
Sound pressure level	Cooling	Low/Medium/High		dBA	28.0/31.0/35.0	29.0/33.0/37.0	29.0/35.0/41.0	29.0/33.0/37.0	29.0/35.0/41.0	29.0/35.0/41.0	
	Heating	Low/Medium/High		dBA	28.0/31.0/33.0	29.0/33.0/37.0	29.0/35.0/41.0	29.0/33.0/37.0	29.0/35.0/41.0	29.0/35.0/41.0	
Control systems	Infrared remote control			BRC7FA532F / BRC7FB532F / BRC7FA532FB / BRC7FB532FB							
	Wired remote control			BRC1H52W/S/K / BRC1E53A / BRC1E53B / BRC1E53C / BRC1D52							
Power supply	Phase/Frequency/Voltage		Hz/V	1~/50/60/220-240/220							
Outdoor unit		ARXM / AZAS		ARXM71R	AZAS100MV	AZAS125MV	AZAS140MV	AZAS100MY	AZAS125MY	AZAS140MY	
Dimensions	Unit	HeightxWidthxDepth	mm	734x954x401		990x940x320					
Weight	Unit		kg	49.0	72	71	79	72	71	79	
Sound power level	Cooling		dBA	-	70	71	73	70	71	73	
	Heating		dBA	-	-	71	73	-	71	73	
Sound pressure level	Cooling	Nom.	dBA	52.0	53	54	54	53	53	54	
	Heating	Nom.	dBA	52.0	57						
Operation range	Cooling	Ambient	Min.~Max.	°CDB		-10~-46					
	Heating	Ambient	Min.~Max.	°CWB		-15~-15.5					
Refrigerant	Type/GWP			R-32/675							
	Charge	kg/TCO2Eq		1.15/0.780	2.60/1.76	2.90/1.96	2.60/1.76	2.60/1.76	2.90/1.96		
Piping connections	Liquid/Gas	OD	mm	9.52/15.9							
	Piping length	OU - IU	Max.	m							
		System	Equivalent	m							
			Chargeless	m							
		Additional refrigerant charge	kg/m	0.035	See installation manual						
	Level difference	IU - OU	Max.	m		30.0					
Power supply	Phase/Frequency/Voltage		Hz/V	1~/50 /220-240				3~/50 /380-415			
Current - 50Hz	Maximum fuse amps (MFA)		A	-	25	32			16		

Contains fluorinated greenhouse gases

Round flow cassette

360° air discharge for optimum efficiency and comfort

- Combination with split outdoor units is ideal for small retail, offices or residential applications
- Optional automatic filter cleaning panel results in higher efficiency & comfort and lower maintenance costs.
- Two optional intelligent sensors improve energy efficiency and comfort
- Widest choice ever in decoration panels: designer panels in white (RAL9010) and black (RAL9005) and standard panels in white (RAL9010) with grey louvers or full white
- Bigger flaps and unique swing pattern improve equal air distribution
- Individual flap control: flexibility to suit every room layout without changing the location of the unit!
- UV streamer kit, purifies the air of pollutants such as viruses, bacteria, fine dust, odours, allergens, etc ensuring a healthy and hygienic indoor environment
- Optional fresh air intake
- Branch duct discharge allows to optimize air distribution in irregular shaped rooms or to supply air to small adjacent rooms
- Standard drain pump with 675mm lift increases flexibility and installation speed



		FCAG-B		RXM-R		RXM-R9		RXM-A			
Efficiency data		FCAG + RXM		35B + 35R9		50B + 50A		60B + 60R			
Cooling capacity	Nom.	kW		3.50		5.00		5.70			
Heating capacity	Nom.	kW		4.20		6.00		7.00			
Space cooling	Energy efficiency class				A++		A++				
	Capacity	Pdesign	kW		3.50		5.00		5.70		
	SEER			6.35		6.54		6.40			
	Annual energy consumption	kWh/a		193		268		312			
Space heating (Average climate)	Energy efficiency class				A++		A+				
	Capacity	Pdesign	kW		3.32		4.36		4.71		
	SCOP/A			4.90		4.30		4.20			
	Annual energy consumption	kWh/a		948		1,418		1,569			
Indoor unit		FCAG		35B		50B		60B			
Dimensions	Unit	HeightxWidthxDepth		mm		204x840x840					
Weight	Unit			kg		18		19			
Air filter	Type					Resin net					
Decoration panel	Model						Standard panels: BYCQ140E - white with grey louvers / BYCQ140EW - full white / BYCQ140EB - black Auto cleaning panels: BYCQ140EGF - white / BYCQ140EGFB - black Designer panels: BYCQ140EP - white / BYCQ140EPB - black				
	Dimensions	HeightxWidthxDepth	mm				Standard panels: 65x950x950 / Auto cleaning panels: 148x950x950 / Designer panels: 106x950x950 Standard panels: 5.5 / Auto cleaning panels: 10.3 / Designer panels: 6.5				
Fan	Air flow rate	Cooling	Low/Medium/High	m³/min		8.8/10.6/12.9		9.4/11.8/14.6		9.6/12.2/14.9	
		Heating	Low/Medium/High	m³/min		9.4/11.6/14.1		9.4/11.8/14.6		9.6/12.2/14.9	
Sound power level	Cooling			dBA		49.0		49.0		51.0	
	Heating			dBA		49.0		49.0		51.0	
Sound pressure level	Cooling	Low/Medium/High			dBA		27.0/29.0/31.0		28.0/31.0/33.0		
	Heating	Low/Medium/High			dBA		27.0/29.0/31.0		28.0/31.0/33.0		
Control systems	Infrared remote control						BRC7FA532F / BRC7FB532F / BRC7FA532FB / BRC7FB532FB				
	Wired remote control						BRC1H52W/S/K / BRC1E53A / BRC1E53B / BRC1E53C / BRC1D52				
Power supply	Phase/Frequency/Voltage				Hz/V		1~/50/60/220-240/220				
Outdoor unit		RXM		35R9		50A		60R			
Dimensions	Unit	HeightxWidthxDepth		mm		552x840x350		734x954x401			
Weight	Unit			kg		32		49.0			
Sound pressure level	Cooling	Nom.		dBA		49.0		48.0			
	Heating	Nom.		dBA		49.0		48.0			
Operation range	Cooling	Ambient	Min.~Max.	°CDB		-10~-46					
	Heating	Ambient	Min.~Max.	°CWB		-15~-18					
Refrigerant	Type					R-32					
	GWP					675.0					
Piping connections	Charge			kg/TCO2Eq		0.76/0.52		1.15/0.780			
	Liquid	OD			mm		6.35		12.7		
Piping length	Gas	OD			mm		9.50		20		
	OU - IU	Max.			m		20		30		
Additional refrigerant charge	System	Chargeless		m				10			
	Level difference	IU - OU	Max.		m		15		20.0		
Power supply	Phase/Frequency/Voltage				Hz/V		1~/50 / 220-240				
Current - 50Hz	Maximum fuse amps (MFA)				A		13		16		

Contains fluorinated greenhouse gases



Fully Flat Cassette Design & Genius in one

Why choose fully flat cassette

- Unique design in the market that integrates fully flat into the ceiling
- Advanced technology and top efficiency combined
- Most quiet cassette available on the market

FFA-A9 / FXZQ-A



Choice between grey or white panel

Benefits for the installer

- Unique product in the market!
- Most quiet unit (25dBA)
- The user-friendly remote control, available in several languages, enables the easy set-up of sensor option and control of the individual flap position
- Meeting European design taste.

Benefits for the consultant

- Unique product in the market!
- Blends seamlessly in any modern office interior design
- Ideal product to improve BREEAM score/EPBD in combination with Sky Air (FFA*) or VRV IV heat pump units (FXZQ*).

Benefits for the end user

- Engineering excellence and unique design in one
- Most quiet unit (25dBA)
- Perfect working conditions: no more cold draughts
- Save up to 27% on your energy bill thanks to the optional sensors
- Flexible usage of space and suits any room configuration thanks to individual flap control
- User-friendly remote control, available in several languages.

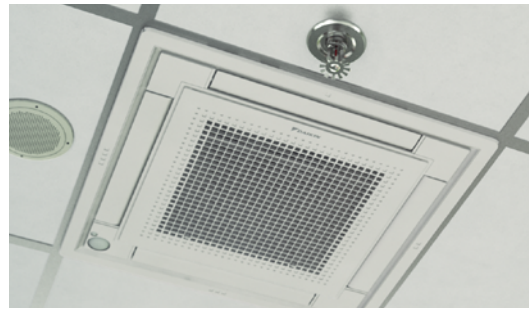
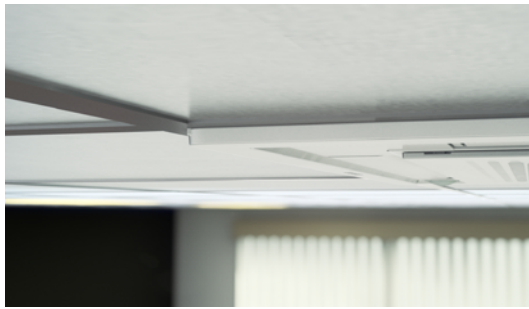

Unique design

- Designed by a European design office to fully meet the European taste.
- Fully flat into the ceiling, leaving only 8mm.
- Fully integrated in the one ceiling tile, enabling lights, speakers and sprinklers to be installed in adjoining ceiling tiles.
- Decoration panel available in 2 colours (white and white-silver).

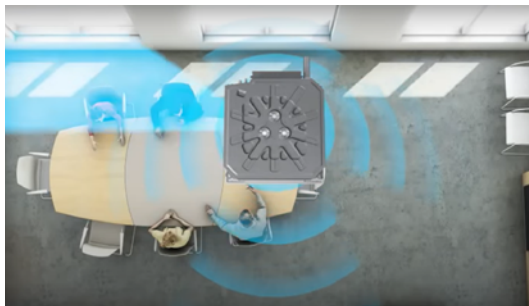

Differentiating in technology

Optional presence sensor

- When the room is empty, it can adjust the set temperature or switch off the unit – saving energy.
- When people are detected, the direction of the airflow is adapted to avoid cold draughts being directed towards occupants.

Optional floor sensor

- Detects the temperature difference and re-directs the airflow to ensure even temperature distribution.

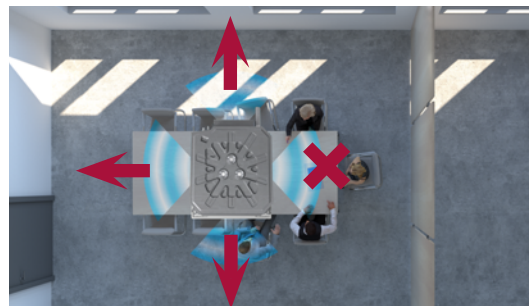

Top efficiency

- Seasonal efficiency labels up to **A++***
- When the room is empty, the sensor option can adjust the set temperature or switch off the unit – saving up to 27% energy.

* for FFA25,35A9 in combination with RXM25,35

Other benefits

- Individual flap control: easily control one or more flaps via the wired remote controller (BRC1E/BRC1H) when rearranging the room. When fully closing or blocking the flaps, the option "Sealing member of air discharge outlet" is needed.
- Most silent cassette in the market (25dBA), important for office applications.

Marketing tools

- https://www.daikin.eu/en_us/product-group/fully-flat-cassette.html
- www.youtube.com/DaikinEurope



Fully flat cassette

Unique design in the market that integrates fully flat into the ceiling

- Combination with Sky Air Alpha-series ensures best in class quality, highest efficiency and performance
- Fully flat integration in standard architectural ceiling tiles, leaving only 8mm
- Remarkable blend of iconic design and engineering excellence with an elegant finish in white or a combination of silver and white
- Two optional intelligent sensors improve energy efficiency and comfort
- Individual flap control: flexibility to suit every room layout without changing the location of the unit!
- Optional fresh air intake
- Branch duct discharge allows to optimize air distribution in irregular shaped rooms or to supply air to small adjacent rooms
- Standard drain pump with 630mm lift increases flexibility and installation speed



FFA-A9

RZAG-A

Efficiency data		FFA + RZAG		35A9 + 35A		50A9 + 50A		60A9 + 60A			
Cooling capacity	Min./Nom./Max.	kW		1.6/3.5/4.5		1.7/5.0/6.0		1.7/6.0/6.5			
Heating capacity	Min./Nom./Max.	kW		1.40/4.00/5.00		1.50/5.80/6.00		1.60/7.00/7.50			
Space cooling	Energy efficiency class				A++		A+				
	Capacity	Pdesign	kW		3.50		5.00		6.00		
	SEER				6.40		6.30		5.80		
	Annual energy consumption		kWh/a		191		278		362		
Space heating (Average climate)	Energy efficiency class				A		A+				
	Capacity	Pdesign	kW		4.20		4.30		4.50		
	SCOP/A				3.80		4.01		4.04		
	Annual energy consumption		kWh/a		1,546		1,501		1,558		
Indoor unit		FFA		35A9		50A9		60A9			
Dimensions	Unit	HeightxWidthxDepth		mm		260x575x575					
Weight	Unit			kg		16.0		17.5			
Air filter	Type					Resin net					
Decoration panel	Model						BYFQ60C2W1W / BYFQ60C2W1S / BYFQ60B2W1 / BYFQ60B3W1				
	Colour						White (N9.5)/SILVER/White (RAL9010)/WHITE (RAL9010)				
	Dimensions		HeightxWidthxDepth		mm		46x620x620 / 46x620x620 / 55x700x700 / 55x700x700				
	Weight				kg		2.8/2.8/2.7/2.7				
Fan	Air flow rate	Cooling	Low/Medium/High	m³/min		6.5/8.5/10.0		8.6/10.9/12.7		9.5/12.5/14.5	
		Heating	Low/Medium/High	m³/min		6.5/8.5/10.0		8.6/10.9/12.7		9.5/12.5/14.5	
Sound power level	Cooling			dBA		51.0		56.0		60.0	
Sound pressure level	Cooling	Low/Medium/High		dBA		25.0/30.5/34.0		27.0/34.0/39.0		32.0/40.0/43.0	
	Heating	Low/Medium/High		dBA		25.0/30.5/34.0		27.0/34.0/39.0		32.0/40.0/43.0	
Control systems	Infrared remote control						BRC7EB530W (standard panel) / BRC7F530W (white panel) / BRC7F530S (grey panel)				
	Wired remote control						BRC1H52W/S/K / BRC1E53A / BRC1E53B / BRC1E53C / BRC1D52				
Power supply	Phase/Frequency/Voltage				Hz/V		1~/50/220-240				
Outdoor unit		RZAG		35A		50A		60A			
Dimensions	Unit	HeightxWidthxDepth		mm		734x870x373					
Weight	Unit			kg		52					
Sound power level	Cooling			dBA		62.0		63.0		64.0	
	Heating			dBA		62.0		63.0		64.0	
Sound pressure level	Cooling	Nom.		dBA		48.0		49.0		50.0	
	Heating	Nom.		dBA		48.0		49.0		50.0	
Operation range	Cooling	Ambient	Min.~Max.	°CDB				-20~-52			
	Heating	Ambient	Min.~Max.	°CWB				-20~-24			
Refrigerant	Type/GWP						R-32/675.0				
	Charge		kg/TCO2Eq				1.55/1.05				
Piping connections	Liquid/Gas OD		mm		6.35/9.52		6.35/12.7				
	Piping length	OU - IU	Max.		m		50				
	Additional refrigerant charge		kg/m				30				
	Level difference IU - OU		Max.		m		30.0				
Power supply	Phase/Frequency/Voltage				Hz/V		1~/50/220-240				

Contains fluorinated greenhouse gases

Fully flat cassette

Unique design in the market that integrates fully flat into the ceiling

- Combination with split outdoor units is ideal for small retail, offices and residential applications
- Fully flat integration in standard architectural ceiling tiles, leaving only 8mm
- Remarkable blend of iconic design and engineering excellence with an elegant finish in white or a combination of silver and white
- Unified indoor unit range for R-32 and R-410A
- Two optional intelligent sensors improve energy efficiency and comfort
- Individual flap control: flexibility to suit every room layout without changing the location of the unit!
- Optional fresh air intake
- Branch duct discharge allows to optimize air distribution in irregular shaped rooms or to supply air to small adjacent rooms
- Standard drain pump with 630mm lift increases flexibility and installation speed

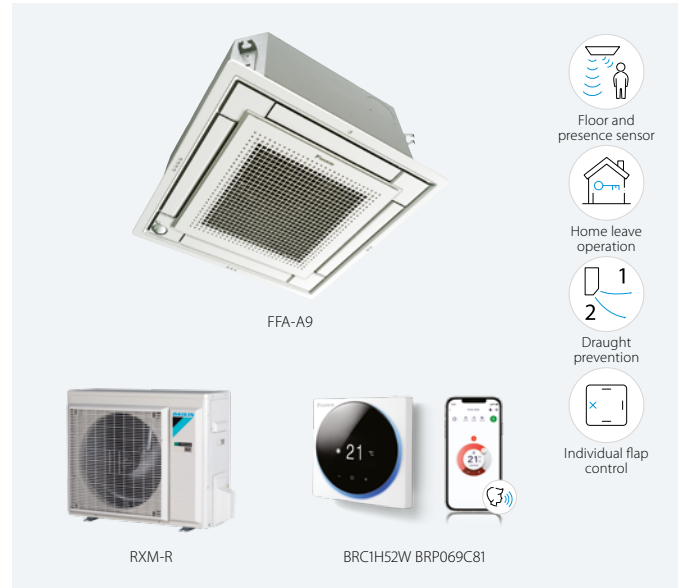

		FFA + RXM	25A9 + 25R9	35A9 + 35R9	50A9 + 50A	60A9 + 60R
Efficiency data	Cooling capacity	Nom. kW	2.50	3.40	5.00	5.70
	Heating capacity	Nom. kW	3.20	4.20	5.80	7.00
Power input	Cooling	Nom. kW	0.55	0.89	1.54	1.86
	Heating	Nom. kW	0.82	1.20	1.66	2.05
Space cooling	Energy efficiency class		A++		A+	
	Capacity	Pdesign kW	2.50	3.40	5.00	5.70
	SEER		6.17	6.38	5.98	5.76
Space heating	Annual energy consumption	kWh/a	142	186	293	346
	Energy efficiency class		A+		A	
	Capacity	Pdesign kW	2.31	3.10	3.84	3.96
(Average climate)	SCOP/A		4.24	4.10	3.90	4.04
	Annual energy consumption	kWh/a	762	1,058	1,378	1,373
	EER		4.57	3.81	3.24	3.05
Nominal efficiency	COP		3.90	3.50	3.49	3.41
	Annual energy consumption	kWh	273	446	772	931
	Energy labeling Directive Cooling/Heating		A/A		A/B	
Indoor unit		FFA	25A9	35A9	50A9	60A9
Dimensions	Unit	HeightxWidthxDepth	mm			
Weight	Unit		16.0		17.5	
Air filter	Type		Resin net			
Decoration panel	Model		BYFQ60C2W1W / BYFQ60C2W1S / BYFQ60B2W1 / BYFQ60B3W1			
	Colour		White (N9.5)/SILVER/White (RAL9010)/WHITE (RAL9010)			
	Dimensions	HeightxWidthxDepth	mm			
Fan	Air flow rate	Cooling	Low/Medium/High	m³/min		
	Heating	Low/Medium/High	m³/min			
Sound power level	Cooling		dBA	48.0		60.0
Sound pressure level	Cooling	Low/Medium/High	dBA	25.0/28.5/31.0		32.0/40.0/43.0
	Heating	Low/Medium/High	dBA	25.0/28.5/31.0		32.0/40.0/43.0
Control systems	Infrared remote control		BRC7EB530W (standard panel) / BRC7F530W (white panel) / BRC7F530S (grey panel)			
	Wired remote control		BRC1H52W/S/K / BRC1E53A / BRC1E53B / BRC1E53C / BRC1D52			
Power supply	Phase/Frequency/Voltage	Hz/V	1~/50 /220-240			
Outdoor unit		RXM	25R9	35R9	50A	60R
Dimensions	Unit	HeightxWidthxDepth	552x840x350		734x954x401	
Weight	Unit		32		49.0	
Sound pressure level	Cooling	Nom.	dBA	46.0		48.0
	Heating	Nom.	dBA	47.0		49.0
Operation range	Cooling	Ambient	Min.~Max.	°CDB		-10~-46
	Heating	Ambient	Min.~Max.	°CWB		-15~-18
Refrigerant	Type		R-32			
	GWP		675		675.0	
Piping connections	Charge	kg/TCO2Eq	0.76/0.52		1.15/0.780	
	Liquid	OD	mm		6.35	
Piping length	Gas	OD	mm		12.7	
	OU - IU	Max. length	m		30	
Additional refrigerant charge	System	Chargeless	m		10	
	Level difference	IU - OU	Max. m		0.02 (for piping length exceeding 10m)	
Power supply	Phase/Frequency/Voltage	Hz/V	15		20.0	
Current - 50Hz	Maximum fuse amps (MFA)	A	13		16	

Contains fluorinated greenhouse gases



Auto cleaning filter for concealed ceiling units

The unique automatic cleaning filter achieves higher efficiency and comfort with lower maintenance costs

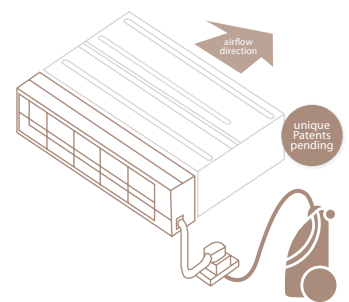

Reduce running costs

- Automatic filter cleaning ensures low maintenance costs because the filter is always clean

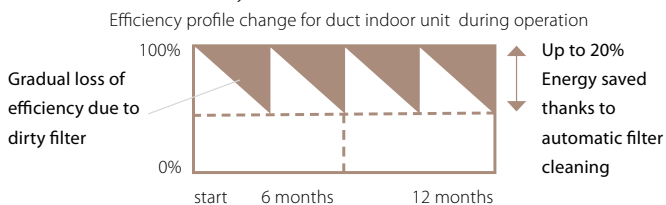

Minimal time required for filter cleaning

- The dust box can be emptied with a vacuum cleaner for fast and easy cleaning
- No more dirty ceilings

Improved indoor air quality

- Optimum airflow eliminates draft and insulates sound

Superb reliability

- Prevents clogged filters for seamless operation

Unique technology

- Unique and innovative filter technology inspired by the Daikin auto cleaning cassette



How does it work?

- Scheduled automatic filter cleaning
- Dust collects in a dust box that's integrated into the unit
- The dust can easily be removed with a vacuum cleaner



Combination table

	Split / Sky Air				VRV						
	FDXM-F9				FXDA-A/FXDQ-A3						
	25	35	50	60	15	20	25	32	40	50	63
BAE20A62	•	•			•	•	•	•			
BAE20A82									•	•	
BAE20A102			•	•							•

Specifications

	BAE20A62	BAE20A82	BAE20A102
Height (mm)	210		
Width (mm)	830	1,030	1,230
Depth (mm)	188		

Multi zoning kit for concealed ceiling units

The multi-zoning system is a room-by-room controller. It is fitted with motorised dampers, which immediately adapt using Daikin ducted solutions. This system supports control of up to 8 zones via a centralised thermostat located in the main room and individual thermostats for each of the zones.

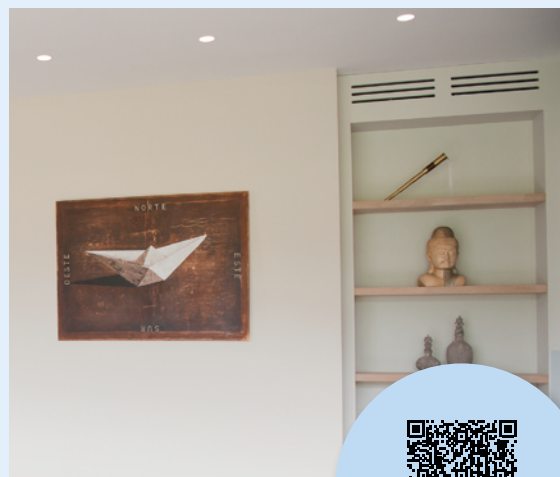

Easy selection via our
NEW software!

Benefits

Increased comfort

- Increases comfort levels by allowing more individual zone control
 - Up to 8 individual zones can be served thanks to separate modulating dampers
 - Individual thermostat for room-by-room or zone-by-zone control

Easy to install

- Automatic air flow adjustment according to the demand
- Easy to install, integrates with the Daikin indoor units and system controls
- Time saving as plenum comes fully pre-assembled with dampers, and control boards
- Reduces the amount of refrigerant required in the installation

How does it work?

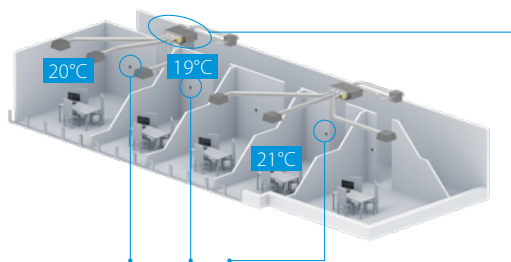

Zoning box:
fully pre-assembled
plenum with
dampers

Individual zone thermostats

Bluezero - Airzone Main Thermostat

- Color graphic interface for controlling zones



AZCE6BLUEZEROCB (Wired)

Airzone Zone Thermostat

- Graphic interface with low-energy e-ink screen for controlling zones



AZCE6THINKRB (Wireless)



Airzone Zone Thermostat

- Thermostat with buttons for controlling the temperature

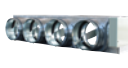

AZCE6LITECB (Wired)
AZCE6LITERB (Wireless)

Compatibility

		SkyAir											VRV IV+																															
		FDXM-F9				FBA-A(9)				ADEA-A			FXDQ-A3						FXSQ-A																									
Number of motorised dampers		Reference	Dimensions H x W x D (mm)		Ø (mm)	25	35	50	60	35	50	60	71	100	125	140	71	100	125	15	20	25	32	40	50	63	15	20	25	32	40	50	63	80	100	125	140							
Standard plenum 	2	AZE(Z/R)6DAIST07XS2	300 x 930 x 454	200																																								
		AZE(Z/R)6DAIST07S2																																										
	3	AZE(Z/R)6DAIST07XS3																																										
		AZE(Z/R)6DAIST07S3																																										
		AZE(Z/R)6DAIST07S4																																										
	4	AZE(Z/R)6DAIST07M4	300 x 1,140 x 454																																									
		AZE(Z/R)6DAIST07M5																																										
		AZE(Z/R)6DAIST07L5	300 x 1,425 x 454																																									
5	AZE(Z/R)6DAIST07M6																																											
	AZE(Z/R)6DAIST07L6	300 x 1,638 x 454																																										
6	AZE(Z/R)6DAIST07L7																																											
	AZE(Z/R)6DAIST07L7	515 x 1,425 x 454																																										
7	AZE(Z/R)6DAIST07XL7																																											
	AZE(Z/R)6DAIST07L8																																											
8	AZE(Z/R)6DAIST07XL8																																											
Medium plenum 	2	AZEZ6DAIBS07XS2	250 x 930 x 454		200																																							
		AZEZ6DAIBS07S2																																										
	3	AZEZ6DAIBS07XS3																																										
		AZEZ6DAIBS07S3																																										
		AZEZ6DAIBS07M3																																										
		AZEZ6DAIBS07S4																																										
	4	AZEZ6DAIBS07M4	250 x 1,140 x 454																																									
		AZEZ6DAIBS07L4																																										
		AZEZ6DAIBS07S5	250 x 1,425 x 454																																									
	5	AZEZ6DAIBS07M5																																										
		AZEZ6DAIBS07L5																																										
		AZEZ6DAIBS07XL5																																										
	AZEZ6DAIBS07M6	250 x 1,638 x 454																																										
6	AZEZ6DAIBS07L6																																											
	AZEZ6DAIBS07XL6																																											
Slim plenum 	2	AZE(Z/R)6DAISL01S2	210 x 720 x 444	200																																								
	3	AZE(Z/R)6DAISL01S3																																										
	4	AZE(Z/R)6DAISL01M4				210 x 930 x 444																																						
	5	AZE(Z/R)6DAISL01L5																																										
						210 x 1,140 x 444																																						

(1) Z models are reversible; R models are heating only

(2) Medium Ceiling Void reversible units can be blocked to heating only via AZX6MCS module

Slim concealed ceiling unit

Compact concealed ceiling unit, with a height of only 200mm

- Combination with Sky Air Alpha-series ensures best in class quality, highest efficiency and performance
- Invisible unit as the unit is concealed in the ceiling: only the suction and discharge grilles are visible
- Compact dimensions, can easily be mounted in a ceiling void of only 240mm
- Medium external static pressure up to 40Pa facilitates unit use with flexible ducts of varying lengths
- Auto cleaning filter option ensures maximum efficiency, comfort and reliability by regular filter cleaning
- Multi zoning kit allows multiple individually-controlled climate zones to be served by one indoor unit
- Onecta app (optional): control your indoor from any location with an app, via your local network or internet and keep an overview on your energy consumption

with auto cleaning and multi zoning option

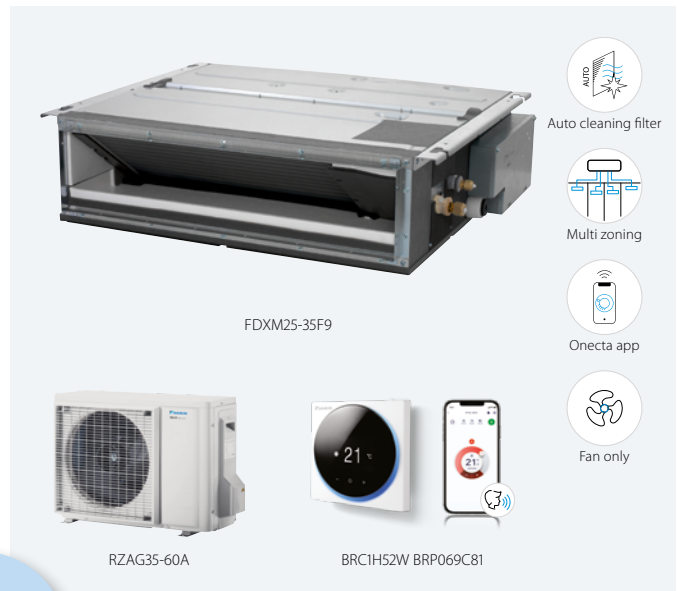

FDXM-F9 RZAG-A

Efficiency data		FDXM + RZAG		35F9 + 35A		50F9 + 50A		60F9 + 60A			
Cooling capacity	Min./Nom./Max.	kW		1.6/3.5/4.5		1.7/5.0/6.0		1.7/6.0/6.5			
Heating capacity	Min./Nom./Max.	kW		1.40/4.00/5.00		1.70/5.00/6.00		1.70/7.00/7.50			
Space cooling	Energy efficiency class					A+					
	Capacity	Pdesign	kW	3.50		5.00		6.00			
	SEER			5.90				5.70			
	Annual energy consumption			kWh/a		208		296		368	
Space heating (Average climate)	Energy efficiency class					A					
	Capacity	Pdesign	kW	3.50		4.30		4.50			
	SCOP/A			3.90							
	Annual energy consumption			kWh/a		1,255		1,544		1,616	
Indoor unit		FDXM		35F9		50F9		60F9			
Dimensions	Unit	HeightxWidthxD	Depth	mm		200x750x620		200x1,150x620			
Weight	Unit				kg		21		28		
Air filter	Type						Removable / washable				
Fan	Air flow rate	Cooling	Low/Medium/High	m ³ /min	7.3/8.0/8.7		13.3/14.6/15.8		13.5/14.8/16.0		
		Heating	Low/Medium/High	m ³ /min	7.3/8.0/8.7		13.3/14.6/15.8		13.5/14.8/16.0		
	External static pressure	Nom.				Pa		30		40	
Sound power level	Cooling				dBA		53.0		55.0		
	Heating				dBA		53.0		55.0		
Sound pressure level	Cooling	Low/High				dBA		27.0/35.0		30.0/38.0	
	Heating	Low/High				dBA		27.0/35.0		30.0/38.0	
Control systems	Infrared remote control					BRC4C65					
	Wired remote control					BRC1H52W/S/K, BRC1E53A/B/C, BRC1D52					
Outdoor unit		RZAG		35A		50A		60A			
Dimensions	Unit	HeightxWidthxD	Depth			mm		734x870x373			
Weight	Unit				kg		52				
Sound power level	Cooling				dBA		62.0		63.0		
	Heating				dBA		62.0		63.0		
Sound pressure level	Cooling	Nom.				dBA		48.0		49.0	
	Heating	Nom.				dBA		48.0		49.0	
Operation range	Cooling	Ambient	Min.~Max.	°CDB		-20~-52					
	Heating	Ambient	Min.~Max.	°CWB		-20~-24					
Refrigerant	Type/GWP					R-32/675.0					
	Charge			kg/TCO ₂ Eq		1.55/1.05					
Piping connections	Liquid/Gas OD			mm		6.35/9.52		6.35/12.7			
	Piping length	OU - IU	Max.	m		50					
		System	Chargeless	m		30					
	Additional refrigerant charge			kg/m		0.02 (for piping length exceeding 30m)					
Power supply	Level difference IU - OU			Max.		m		30.0			
	Phase/Frequency/Voltage			Hz/V		1~/50/220-240					

Contains fluorinated greenhouse gases

Slim concealed ceiling unit

Compact concealed ceiling unit, with a height of only 200mm

- Combination with split outdoor units is ideal for small retail, offices and residential applications
- Invisible unit as the unit is concealed in the ceiling: only the suction and discharge grilles are visible
- Compact dimensions, can easily be mounted in a ceiling void of only 240mm
- Medium external static pressure up to 40Pa facilitates unit use with flexible ducts of varying lengths
- Auto cleaning filter option ensures maximum efficiency, comfort and reliability by regular filter cleaning
- Multi zoning kit allows multiple individually-controlled climate zones to be served by one indoor unit
- Onecta app (optional): control your indoor from any location with an app, via your local network or internet.

with auto cleaning and multi zoning option



FDXM-F9 RXM-R RXM-R9 RXM-A

Efficiency data		FDXM + RXM	25F9 + 25R9	35F9 + 35R9	50F9 + 50A	60F9 + 60R	
Cooling capacity	Nom.	kW	1.30/2.40/3.00	1.40/3.40/3.80	1.70/5.00/5.30	1.70/6.00/6.50	
Heating capacity	Nom./Max.	kW	1.30/3.20/4.50	1.40/4.00/5.00	1.70/5.80/6.00	1.70/7.00/7.10	
Space cooling	Energy efficiency class		A+	A	A+	A	
	Capacity	Pdesign	kW	2.40	3.40	5.00	6.00
	SEER			5.26	5.77	5.56	
	Annual energy consumption		kWh/a	148	226	303	378
Space heating (Average climate)	Energy efficiency class		A+	A		A	
	Capacity	Pdesign	kW	2.60	2.90	4.00	4.60
	SCOP/A			4.24	3.88	3.93	3.80
	Annual energy consumption		kWh/a	858	1,046	1,424	1,693

Indoor unit		FDXM		25F9	35F9	50F9	60F9
Dimensions	Unit	HeightxWidthxDepth	mm	200x750x620		200x1,150x620	
Weight	Unit		kg	21		28	
Air filter	Type			Removable/washable			
Fan	Air flow rate	Cooling	Low/Medium/High	7.3/8.0/8.7		13.3/14.6/15.8	
		Heating	Low/Medium/High	7.3/8.0/8.7		13.3/14.6/15.8	
	External static pressure	Nom.	Pa	30		40	
Sound power level	Cooling		dB(A)	53.0		55.0	
	Heating		dB(A)	53.0		55.0	
Sound pressure level	Cooling	Low/High	dB(A)	27.0/35.0		30.0/38.0	
	Heating	Low/High	dB(A)	27.0/35.0		30.0/38.0	

Outdoor unit		RXM		25R9	35R9	50A	60R	
Dimensions	Unit	HeightxWidthxDepth	mm	552x840x350		734x954x401		
Weight	Unit		kg	32		49.0		
Sound pressure level	Cooling	Nom.	dB(A)	46.0		49.0		
	Heating	Nom.	dB(A)	47.0		49.0		
Operation range	Cooling	Ambient	Min.~Max.	°CDB		-10~46		
	Heating	Ambient	Min.~Max.	°CWB		-15~18		
Refrigerant	Type			R-32		R-32		
	GWP			675		675.0		
	Charge		kg/TCO2Eq	0.76/0.52		1.15/0.780		
Piping connections	Liquid	OD	mm			6.35		
	Gas	OD	mm	9.50		12.7		
	Piping length	OU - IU	Max.	m	20		30	
		System	Chargeless	m	10		10	
	Additional refrigerant charge		kg/m	0.02 (for piping length exceeding 10m)		0.02 (for piping length exceeding 10m)		
Level difference IU - OU	Max.	m	15		20.0			
Power supply	Phase/Frequency/Voltage	Hz/V	1~/50 /220-240		1~/50 /220-240			
Current - 50Hz	Maximum fuse amps (MFA)	A	13		16			

Contains fluorinated greenhouse gases

Concealed ceiling unit with medium ESP

Slimmest yet most powerful medium static pressure unit on the market

- Slimmest unit in class, only 245mm (300mm built-in height) and therefore narrow ceiling voids are no longer a challenge
- Low operation sound level down to 25dBA
- Medium external static pressure up to 150Pa facilitates using flexible ducts of varying lengths
- Possibility to change ESP via wired remote control allows optimisation of the supply air volume
- Discretely concealed in the ceiling: only the suction and discharge grilles are visible
- Multi zoning kit allows multiple individually-controlled climate zones to be served by one indoor unit
- Optional fresh air intake
- Flexible installation: air suction direction can be altered from rear to bottom suction and choice between free use or connection to optional suction grilles
- Standard built-in drain pump with 625mm lift increases flexibility and installation speed

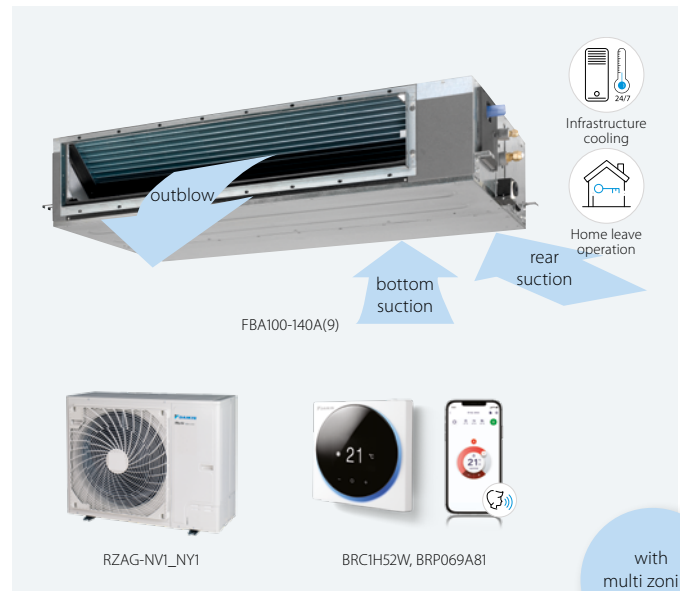

		FBA-A(9)		RZAG-A		RZAG-NV1		RZAG-NY1											
Efficiency data		FBA + RZAG	35A9+35A	50A9+50A	60A9+60A	71A9+71NV1	100A+100NV1	125A+125NV1	140A+140NV1	71A9+71NY1	100A+100NY1	125A+125NY1	140A+140NY1						
Cooling capacity	Min./Nom./Max.	kW		1.6/3.5/5.0	1.7/5.0/6.0	1.7/6.0/7.0	-/6.80/-	-/9.50/-	-/12.1/-	-/13.4/-	-/6.80/-	-/9.50/-	-/12.1/-	-/13.4/-					
Heating capacity	Min./Nom./Max.	kW		1.40/4.00/5.00	1.70/6.00/6.00	1.70/7.00/7.50	-/7.50/-	-/10.8/-	-/13.5/-	-/15.5/-	-/7.50/-	-/10.8/-	-/13.5/-	-/15.5/-					
Space cooling	Energy efficiency class			A++				-		A++									
	Capacity	Pdesign	kW	3.50	5.00	6.00	6.80	9.50	12.1	13.4	6.80	9.50	12.1	13.4					
	SEER			6.12	6.30	6.15	6.50	6.47	6.56	6.42	6.50	6.47	6.56	6.42					
	ηs,c		%	-				259	254	-		259	254						
	Annual energy consumption		kWh/a	200	278	341	366	514	1,107	1,252	366	514	1,107	1,252					
Space heating (Average climate)	Energy efficiency class			A+				-		A+									
	Capacity	Pdesign	kW	4.20	4.30	4.50	4.70	7.80	9.52		4.70	7.80	9.52						
	SCOP/A			4.10		4.20	4.36	4.37	4.34	4.20	4.36	4.37	4.34						
	ηs,h		%	-				172	171	-		172	171						
	Annual energy consumption		kWh/a	1,434	1,469	1,537	1,566	2,505	3,050	3,070	1,566	2,505	3,050	3,070					
Indoor unit		FBA	35A9	50A9	60A9	71A9	100A	125A	140A	71A9	100A	125A	140A						
Dimensions	Unit	HeightxWidthxDpeth	mm		245x700x800		245x1,000x800		245x1,400x800		245x1,000x800		245x1,400x800						
Weight	Unit		kg		28.0		35.0		46.0		35.0		46.0						
Air filter	Type		Resinnet																
Fan	Air flow rate	Cooling	Low/Medium/High	m³/min		10.5/12.5/15.0		12.5/15.0/18.0		23.0/26.0/29.0		23.5/29.0/34.0		12.5/15.0/18.0		23.0/26.0/29.0		23.5/29.0/34.0	
		Heating	Low/Medium/High	m³/min		10.5/12.5/15.0		12.5/15.0/18.0		23.0/26.0/29.0		23.5/29.0/34.0		12.5/15.0/18.0		23.0/26.0/29.0		23.5/29.0/34.0	
	External static pressure	Nom./High	Pa		30/150		40/150		50/150		30/150		40/150		50/150				
Sound power level	Cooling		dBA		60.0		56.0		58.0		62.0		56.0		58.0		62.0		
Sound pressure level	Cooling	Low/High	dBA		29.0/35.0		25.0/30.0		30.0/34.0		32.0/37.0		25.0/30.0		30.0/34.0		32.0/37.0		
	Heating	Low/High	dBA		29.0/37.0		25.0/31.0		30.0/36.0		32.0/38.0		25.0/31.0		30.0/36.0		32.0/38.0		
Control systems	Infrared remote control		BRC4C65 / BRC4C66																
	Wired remote control		BRC1H52W/S/K / BRC1E53A / BRC1E53B / BRC1E53C / BRC1D52																
Power supply	Phase/Frequency/Voltage		Hz/V		1~/50/60/220-240/220														
Piping connections	Drain		VP20 (I.D. 20/O.D. 26)																
Drain-up height			mm		625														
Outdoor unit		RZAG	35A	50A	60A	71NV1	100NV1	125NV1	140NV1	71NY1	100NY1	125NY1	140NY1						
Dimensions	Unit	HeightxWidthxDpeth	mm		734x870x373				870x1,100x460										
Weight	Unit		kg		52		81	85	95		81	85	94						
Sound power level	Cooling		dBA		62.0	63.0	64.0	64	66	69	70	64	66	69	70				
	Heating		dBA		62.0	63.0	64.0	-	-	68	71	-	-	68	71				
Sound pressure level	Cooling	Nom.	dBA		48.0	49.0	50.0	46	47	49	50	46	47	49	50				
	Heating	Nom.	dBA		48.0	49.0	50.0	48	50	52		48	50	52					
Operation range	Cooling	Ambient	Min.~Max.	°CDB		-20 ~ 52				-20 ~ 52									
	Heating	Ambient	Min.~Max.	°CWB		-20 ~ 24				-20 ~ 18									
Refrigerant	Type/GWP		R-32/675.0																
	Charge		kg/TCO2Eq		1.55/1.05		3.20/2.16		3.70/2.50		3.20/2.16		3.70/2.50						
Piping connections	Liquid/Gas OD		mm		6.35/9.52		6.35/12.7		9.52/15.9										
	Piping length	OU - IU	m		50		55		85		55		85						
		System	Equivalent		-		75		100		75		100						
		Chargeless	m		30		40												
		Level difference IU - OU	Max.		m		30.0		30										
	Additional refrigerant charge		kg/m		0.02 (for piping length exceeding 30m)		See installation manual												
Power supply	Phase/Frequency/Voltage		Hz/V		1~/50 / 220-240							3~/50 / 380-415							
Current - 50Hz	Maximum fuse amps (MFA)		A		-		20		32		16								

Contains fluorinated greenhouse gases

Concealed ceiling unit with medium ESP

Slimmest yet most powerful medium static pressure unit on the market

- Combination with Sky Air Advance-series ensures good value for money for all types of commercial applications
- Slimmest unit in class, only 245mm (300mm built-in height) and therefore narrow ceiling voids are no longer a challenge
- Low operation sound level down to 25dBA
- Medium external static pressure up to 150Pa facilitates using flexible ducts of varying lengths
- Possibility to change ESP via wired remote control allows optimisation of the supply air volume

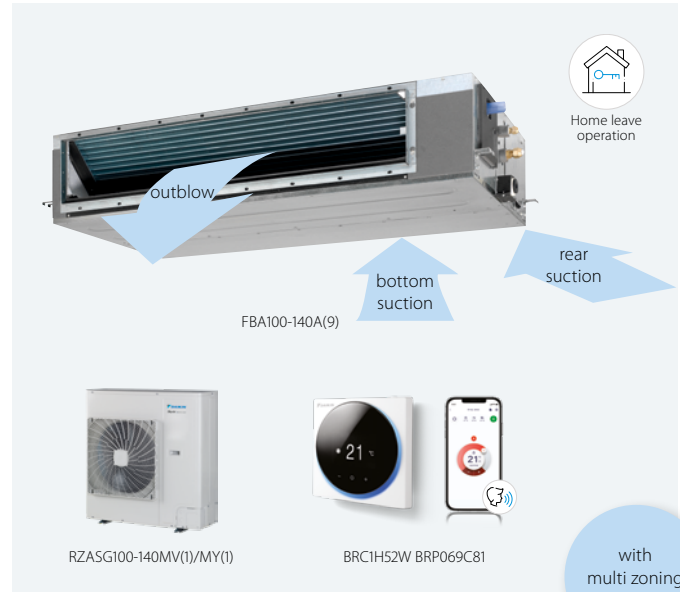

Optimised supply air volume

Automatically selects the most appropriate fan speed to achieve the units' nominal air flow within ±10%

Why?

After installation the real ducting will frequently differ from the initially calculated air flow resistance → the real air flow may be much lower or higher than nominal, leading to a lack of capacity or uncomfortable air temperature. Automatic Airflow Adjustment function will adapt the unit's fan speed to any ducting automatically (10 or more fan speeds are available on every model), making installation much faster

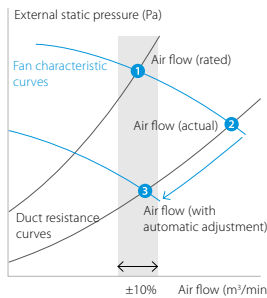

FBA-A(9) RZASG-MV1 RZASG-MY1 RZASG-MV RZASG-MY

Efficiency data		FBA + RZASG		71A9 + 71MV1	100A + 100MV(1)	125A + 125MV(1)	140A + 140MV(1)	100A + 100MY(1)	125A + 125MY(1)	140A + 140MY(1)	
Cooling capacity	Nom.	kW		6.80	9.50	12.1	13.4	9.50	12.1	13.4	
Heating capacity	Nom.	kW		7.50	10.8	13.5	15.5	10.8	13.5	15.5	
Space cooling	Energy efficiency class			A++	A+			A+			
	Capacity	Pdesign	kW	6.80	9.50	12.1	13.4	9.50	12.1	13.4	
	SEER			6.19	5.83	5.49	5.81	5.83	5.49	5.81	
	ηs,c		%			217	229		217	229	
Space heating (Average climate)	Energy efficiency class			A+	A			A			
	Capacity	Pdesign	kW	4.50		6.00	7.80		6.00	7.80	
	SCOP/A			4.01	3.85	3.63		3.85	3.63	3.85	
	ηs,h		%			142	151		142	151	
	Annual energy consumption		kWh/a	1,571	2,182	2,314	2,836	2,182	2,314	2,836	
Indoor unit		FBA		71A9	100A	125A	140A	100A	125A	140A	
Dimensions	Unit	HeightxWidthxDpeth	mm	245x1,000x800		245x1,400x800					
Weight	Unit		kg	35.0		46.0					
Air filter	Type			Resin net							
Fan	Air flow rate	Cooling	Low/Medium/High	m³/min	12.5/15.0/18.0	20.0/24.5/29.0	23.5/29.0/34.0		20.0/24.5/29.0	23.5/29.0/34.0	
		Heating	Low/Medium/High	m³/min	12.5/15.0/18.0	20.0/24.5/29.0	23.5/29.0/34.0		20.0/24.5/29.0	23.5/29.0/34.0	
		External static pressure	Nom.	Pa	30	40	50		40	50	
Sound power level	Cooling		dBA	56.0	58.0	62.0		58.0	62.0		
Sound pressure level	Cooling	Low/Medium/High	dBA	25.0/28.0/30.0	30.0/32.0/34.0	32.0/35.0/37.0		30.0/32.0/34.0	32.0/35.0/37.0		
	Heating	Low/Medium/High	dBA	25.0/28.0/31.0	30.0/33.0/36.0	32.0/35.0/38.0		30.0/33.0/36.0	32.0/35.0/38.0		
Control systems	Infrared remote control			BRC4C65 / BRC4C66							
	Wired remote control			BRC1H52W/S/K / BRC1E53A / BRC1E53B / BRC1E53C / BRC1D52							
Power supply	Phase/Frequency/Voltage		Hz/V	1~/50/60/220-240/220							
Outdoor unit		RZASG		71MV1	100MV(1)	125MV(1)	140MV(1)	100MY(1)	125MY(1)	140MY(1)	
Dimensions	Unit	HeightxWidthxDpeth	mm	770x900x320		990x940x320					
Weight	Unit		kg	60	70 (MY1) / 72 (MY)		78 (MV1) / 79 (MV)	70 (MY1) / 72 (MY)		78 (MV1) / 79 (MV)	
Sound power level	Cooling		dBA	65	70	71	73	70	71	73	
	Heating		dBA			71	73		71	73	
Sound pressure level	Cooling	Nom.	dBA	46	53		54	53		54	
	Heating	Nom.	dBA	47	57						
Operation range	Cooling	Ambient	Min.~Max.			-15~-46					
	Heating	Ambient	Min.~Max.			-15~-15.5					
Refrigerant	Type/GWP			R-32/675							
Piping connections	Charge		kg/TCO2eq	2.45/1.65	2.60/1.76		2.90/1.96	2.60/1.76		2.90/1.96	
	Liquid/Gas OD		mm	9.52/15.9							
Piping length	Piping	OU - IU	Max.			50					
	System	Equivalent	m			70					
		Chargeless	m			30					
	Additional refrigerant charge		kg/m	See installation manual							
Level difference	IU - OU	Max.	m	30.0							
Power supply	Phase/Frequency/Voltage		Hz/V	1~/50 / 220-240				3~/50 / 380-415			
Current - 50Hz	Maximum fuse amps (MFA)		A	20	25	32		16			

Contains fluorinated greenhouse gases

Concealed ceiling unit with medium ESP

Slimmest yet most powerful medium static pressure unit on the market

- Ideal solution for small businesses and shops
- Slimmest unit in class, only 245mm (300mm built-in height) and therefore narrow ceiling voids are no longer a challenge
- Low operation sound level down to 25dBA
- Medium external static pressure up to 150Pa facilitates using flexible ducts of varying lengths
- Possibility to change ESP via wired remote control allows optimisation of the supply air volume
- Discretely concealed in the ceiling: only the suction and discharge grilles are visible
- Multi zoning kit allows multiple individually-controlled climate zones to be served by one indoor unit
- Reduced energy consumption thanks to specially developed DC fan motor
- Optional fresh air intake
- Flexible installation: air suction direction can be altered from rear to bottom suction and choice between free use or connection to optional suction grilles
- Standard built-in drain pump with 625mm lift increases flexibility and installation speed

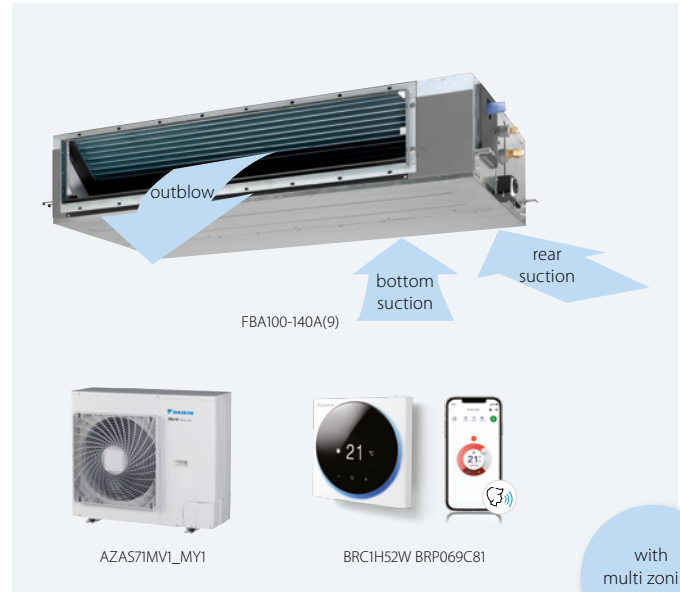

		FBA-A(9)		ARXM-R		AZAS-MV		AZAS-MY			
Efficiency data		FBA + ARXM/AZAS		71A9 + ARXM71R	100A + AZAS100MV	125A + AZAS125MV	140A + AZAS140MV	100A + AZAS100MY	125A + AZAS125MY	140A + AZAS140MY	
Cooling capacity	Nom./Max.	kW		6.80/6.98	9.50/-	12.1/-	13.4/-	9.50/-	12.1/-	13.4/-	
Heating capacity	Nom./Max.	kW		7.50/7.66	10.8/-	13.5/-	15.5/-	10.8/-	13.5/-	15.5/-	
Space cooling	Energy efficiency class		A		-		A		-		
	Capacity	Pdesign	kW		6.80	9.50	12.1	13.0	9.50	12.1	13.0
	SEER				5.57	5.7	5.2	5.7	5.7	5.2	5.7
	ηs,c		%		-	-	205	225	-	205	225
	Annual energy consumption		kWh/a		427	633	1,497	1,418	633	1,497	1,418
Space heating (Average climate)	Energy efficiency class		A		-		A		-		
	Capacity	Pdesign	kW		4.50	6.00	7.80	6.00	7.80	6.00	
	SCOP/A				3.81	-	3.55	3.85	3.81	3.55	3.85
	ηs,h		%		-	-	139	151	-	139	151
	Annual energy consumption		kWh/a		1,652	2,205	2,366	2,836	2,205	2,366	2,836
Indoor unit		FBA		71A9	100A	125A	140A	100A	125A	140A	
Dimensions	Unit	HeightxWidthxDpeth	mm		245x1,000x800	245x1,400x800					
Weight	Unit		kg		35.0	46.0					
Air filter	Type	Resin net									
Fan	Air flow rate	Cooling	Low/Medium/High	m ³ /min	12.5/15.0/18.0	20.0/24.5/29.0	23.5/29.0/34.0	20.0/24.5/29.0	23.5/29.0/34.0	20.0/24.5/29.0	23.5/29.0/34.0
		Heating	Low/Medium/High	m ³ /min	12.5/15.0/18.0	20.0/24.5/29.0	23.5/29.0/34.0	20.0/24.5/29.0	23.5/29.0/34.0	20.0/24.5/29.0	23.5/29.0/34.0
	External static pressure	Nom.	Pa		30	40	50	40	50		
Sound power level	Cooling		dBA	56.0	58.0	62.0	58.0	62.0			
Sound pressure level	Cooling	Low/Medium/High	dBA	25.0/28.0/30.0	30.0/32.0/34.0	32.0/35.0/37.0	30.0/32.0/34.0	32.0/35.0/37.0	25.0/28.0/31.0	30.0/33.0/36.0	
	Heating	Low/Medium/High	dBA	25.0/28.0/31.0	30.0/33.0/36.0	32.0/35.0/38.0	30.0/33.0/36.0	32.0/35.0/38.0			
Control systems	Infrared remote control		BRC4C65 / BRC4C66								
	Wired remote control		BRC1H52W/S/K / BRC1E53A / BRC1E53B / BRC1E53C / BRC1D52								
Power supply	Phase/Frequency/Voltage		Hz/V								
				1~/50/60/220-240/220							
Outdoor unit		ARXM/AZAS		ARXM71R	AZAS100MV	AZAS125MV	AZAS140MV	AZAS100MY	AZAS125MY	AZAS140MY	
Dimensions	Unit	HeightxWidthxDpeth	mm		734x954x401	990x940x320					
Weight	Unit		kg		49.0	72	79	72	79		
Sound power level	Cooling		dBA		-	70	71	73	70	71	73
	Heating		dBA		-	-	71	73	-	71	73
Sound pressure level	Cooling	Nom.	dBA		52.0	53	54	53	54		
	Heating	Nom.	dBA		52.0	-	57	-	57		
Operation range	Cooling	Ambient	Min.~Max.	°CDB	-10~46						
	Heating	Ambient	Min.~Max.	°CWB	-15~24						
Refrigerant	Type/GWP		R-32/675								
	Charge		kg/TCO2Eq	1.15/0.780	2.60/1.76	2.90/1.96	2.60/1.76	2.90/1.96			
Piping connections	Liquid/Gas OD		mm		9.52/15.9						
	Piping length	OU - IU	Max.	m	30						
		System Equivalent Chargeless		m	50						
	Additional refrigerant charge		kg/m	0.035	30						
				(for piping length exceeding 10m)	See installation manual						
Level difference	IU - OU	Max.	m	20.0							
Power supply	Phase/Frequency/Voltage		Hz/V		1~/50 /220-240				3~/50 /380-415		
Current - 50Hz	Maximum fuse amps (MFA)		A		-	25	32	-	16		

Contains fluorinated greenhouse gases

Concealed ceiling unit with medium ESP

Slimmest yet most powerful medium static pressure unit on the market

- Combination with split outdoor units is ideal for small retail, offices and residential applications
- Slimmest unit in class, only 245mm (300mm built-in height) and therefore narrow ceiling voids are no longer a challenge
- Low operation sound level down to 25dBA
- Medium external static pressure up to 150Pa facilitates using flexible ducts of varying lengths
- Possibility to change ESP via wired remote control allows optimisation of the supply air volume

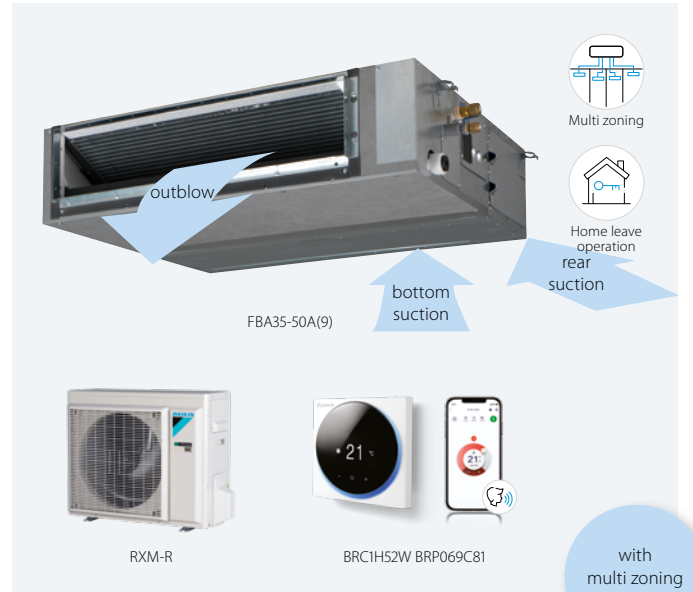

Optimised supply air volume

Automatically selects the most appropriate fan curve to achieve the units' nominal air flow within ±10%

Why?

After installation the real ducting will frequently differ from the initially calculated air flow resistance → the real air flow may be much lower or higher than nominal, leading to a lack of capacity or uncomfortable air temperature. Automatic Airflow Adjustment function will adapt the unit's fan speed to any ducting automatically (10 or more fan curves are available on every model), making installation much faster

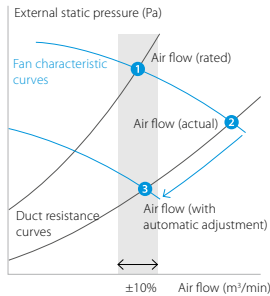

FBA-A(9) RXM-R RXM-R9 RXM-A

Efficiency data		FBA + RXM	35A9 + 35R9	50A9 + 50A	60A9 + 60R	
Cooling capacity	Nom.	kW	3.40	5.00	5.70	
Heating capacity	Nom.	kW	4.00	5.50	7.00	
Space cooling	Energy efficiency class		A++			
	Capacity	Pdesign	kW	3.40	5.00	5.70
	SEER			6.23	6.27	5.91
	Annual energy consumption		kWh/a	191	279	336
Space heating (Average climate)	Energy efficiency class		A+			
	Capacity	Pdesign	kW	2.90	4.40	4.60
	SCOP/A			4.07	4.06	4.01
	Annual energy consumption		kWh/a	996	1,517	1,607

Indoor unit		FBA	35A9	50A9	60A9
Dimensions	Unit	HeightxWidthxDepth	245x700x800		245x1,000x800
Weight	Unit		28.0		35.0
Air filter	Type		Resin net		
Fan	Air flow rate	Cooling	Low/Medium/High m³/min		12.5/15.0/18.0
	Heating	Low/Medium/High m³/min	10.5/12.5/15.0		12.5/15.0/18.0
	External static pressure	Nom.	Pa		30
Sound power level	Cooling		dBA		60.0
Sound pressure level	Cooling	Low/Medium/High	dBA		29.0/32.0/35.0
	Heating	Low/Medium/High	dBA		29.0/34.0/37.0
Control systems	Infrared remote control		BRC4C65 / BRC4C66		
	Wired remote control		BRC1H52W/S/K / BRC1E53A / BRC1E53B / BRC1E53C / BRC1D52		
Power supply	Phase/Frequency/Voltage	Hz/V	1~/50/60/220-240/220		

Outdoor unit		RXM	35R9	50A	60R
Dimensions	Unit	HeightxWidthxDepth	552x840x350		734x954x401
Weight	Unit		kg		32
Sound pressure level	Cooling	Nom.	dBA		49.0
	Heating	Nom.	dBA		49.0
Operation range	Cooling	Ambient	Min.~Max.		°CDB
	Heating	Ambient	Min.~Max.		°CWB
Refrigerant	Type		R-32		
	GWP		675.0		
Piping connections	Charge		kg/TCO2Eq		0.76/0.52
	Liquid	OD	mm		6.35
Piping connections	Gas	OD	mm		9.52
	Piping length	OU - IU Max. System Chargeless	m		20
Piping connections	Additional refrigerant charge		kg/m		
	Level difference	IU - OU Max.	m		15
Power supply	Phase/Frequency/Voltage	Hz/V	1~/50 / 220-240		
Current - 50Hz	Maximum fuse amps (MFA)	A	13		16

Contains fluorinated greenhouse gases

Concealed ceiling unit with high ESP

ESP up to 200 Pa, ideal for large sized spaces

- High external static pressure up to 200Pa facilitates extensive duct and grille network
- Possibility to change ESP via wired remote control allows optimisation of the supply air volume
- Discretely concealed in the ceiling: only the suction and discharge grilles are visible
- Built-in drain pump (625mm) increases the flexibility and installation speed (standard for FDA125, optional for FDA200-250)
- Standard supplied suction filter simplifies installation

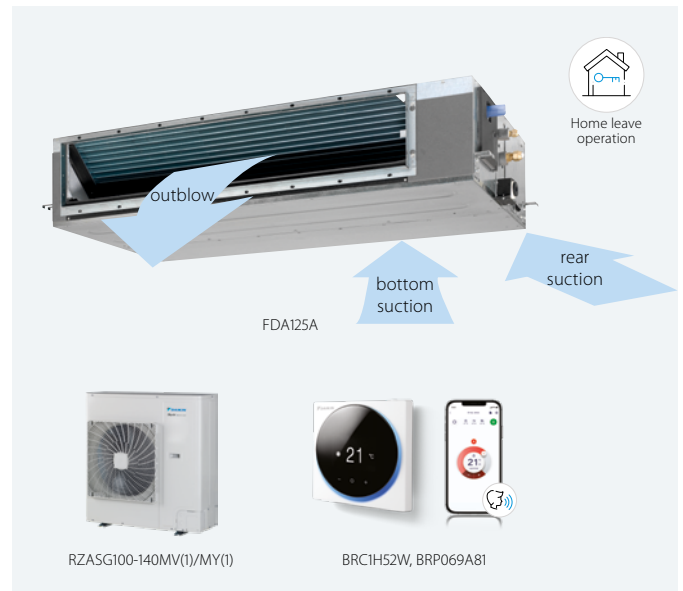

FDA-A RZAG-NV1 RZAG-NY1 RZASG-MV1 RZASG-MY1 RZASG-MV RZASG-MY

		Sky Air Alpha-series				Sky Air Advance-series							
		FDA125A+RZAG125NV1		FDA125A+RZAG125NY1		FDA125A+RZASG125MV(1)		FDA125A+RZASG125MY(1)					
Efficiency data	Cooling capacity	Nom.					12.1						
	Heating capacity	Nom.					13.5						
	Space cooling	Capacity	Pdesign				12.1						
		SEER			6.59		5.03						
	ηs,c			261		198							
	Annual energy consumption			1,102		1,444							
Space heating (Average climate)	Capacity	Pdesign		9.52		6.00							
	SCOP/A			4.35		3.58							
	ηs,h			171		140							
	Annual energy consumption			3,064		2,346							
Indoor unit		FDA		125A		125A		125A					
Dimensions	Unit	HeightxWidthxDepth		mm		300x1,400x700							
Weight	Unit			kg		45							
Required ceiling void >					mm		350						
Air filter	Type						Resin net						
Decoration panel	Model						BYBS125DJW1						
	Colour						White (10Y9/0.5)						
	Dimensions	HeightxWidthxDepth		mm		55x1,500x500							
	Weight			kg		6.5							
Fan	Air flow	Cooling	Low/High	m³/min		28.0/39.0							
	rate	Heating	Low/High	m³/min		28.0/39.0							
	External static pressure	Nom./High		Pa		50/200							
Sound power level	Cooling				dBA		66						
Sound pressure level	Cooling	Low/High		dBA		33/40							
	Heating	Low/High		dBA		33/40							
Control systems	Infrared remote control						BRC4C65/BRC4C66						
	Wired remote control						BRC1H52W/S/K/BRC1E53A/BRC1E53B/BRC1E53C/BRC1D52						
Power supply	Phase/Frequency/Voltage				Hz/V		1~/50/60/220-240/220						
Piping connections	Drain						VP25 (I.D. 25/O.D. 32)						
Outdoor unit				RZAG125NV1		RZAG125NY1		RZASG125MV(1)		RZASG125MY(1)			
Dimensions	Unit	HeightxWidthxDepth		mm		870x1,100x460		990x940x320					
Weight	Unit			kg		95		94		70 (MV1/MY1)/72 (MV/MY)			
Sound power level	Cooling			dBA		69		68		71			
	Heating			dBA		68		-		-			
Sound pressure level	Cooling	Nom.		dBA		49		54		54			
	Heating	Nom.		dBA		52		58		58			
Operation range	Cooling	Ambient	Min.~Max.	°CDB		-20~-52		-15~-46					
	Heating	Ambient	Min.~Max.	°CWB		-20~-18		-15~-15.5					
Refrigerant	Type/GWP						R-32/675		R-32/675				
	Charge				kg/TCO2Eq		3.70/2.50		2.60/1.76				
Piping connections	Liquid/Gas OD				mm		9.52/15.9		9.52/15.9				
	Piping length	OU - IU	Max.		m		85		50				
		System	Equivalent		m		100		70				
		Chargeless				m		40		30			
		Level difference	IU - OU	Max.		m		30		30.0			
	Additional refrigerant charge				kg/m		See installation manual		See installation manual				
Power supply	Phase/Frequency/Voltage				Hz/V		1~/50/220-240		3~/50/380-415		1~/50/220-240		
Current - 50Hz	Maximum fuse amps (MFA)				A		32		16		32		

Contains fluorinated greenhouse gases

Concealed ceiling unit with high ESP

ESP up to 250 Pa, ideal for large sized spaces

- High external static pressure up to 250Pa facilitates extensive duct and grille network
- Possibility to change ESP via wired remote control allows optimisation of the supply air volume
- Discretely concealed in the ceiling: only the suction and discharge grilles are visible
- Optional drain pump
- Standard supplied suction filter simplifies installation
- Up to 26.4kW in heating mode



FDA-A RZA-D

Efficiency data		FDA + RZA		200A + 200D		250A + 250D	
Cooling capacity	Min./Nom./Max.	kW		-/19.0/-		-/22.0/-	
Heating capacity	Min./Nom./Max.	kW		-/22.4/-		-/24.0/-	
Space cooling	Capacity	Pdesign kW		19.0		22.0	
	SEER			6.26		5.38	
	ηs,c	%		247		212	
	Annual energy consumption	kWh/a		1,821		2,455	
Space heating (Average climate)	Capacity	Pdesign kW		11.2		12.1	
	SCOP/A			3.59		3.55	
	ηs,h	%		141		139	
	Annual energy consumption	kWh/a		4,368		4,765	
Indoor unit		FDA		200A		250A	
Dimensions	Unit	HeightxWidthxDepth mm		470x1,490x1,100			
Weight	Unit	kg		104		115	
Air filter	Type			Resinnet			
Fan	Air flow rate	Cooling	Low/Medium/High m³/min	36.0/50/64.0		43.0/56/69.0	
		Heating	Low/Medium/High m³/min	36.0/50.0/64.0		43.0/56.0/69.0	
	External static pressure	Nom./High	Pa	62/250			
Sound power level	Cooling	dBA		69.0		71.0	
Sound pressure level	Cooling	Low/Medium/High dBA		36.0/39.0/43.0		37.0/40.0/44.0	
	Heating	Low/Medium/High dBA		36.0/39.0/43.0		37.0/40.0/44.0	
Control systems	Wired remote control				BRC1H52W/S/K / BRC1E53A / BRC1E53B / BRC1E53C / BRC1D52		
Piping connections	Drain				BSP1		
Outdoor unit		RZA		200D		250D	
Dimensions	Unit	HeightxWidthxDepth mm		870x1,100x460			
Weight	Unit	kg		117			
Sound power level	Cooling	dBA		73		76	
	Heating	dBA		76		79	
Sound pressure level	Cooling	Nom. dBA		53		57	
	Heating	Nom. dBA		60		63	
Operation range	Cooling	Ambient	Min.~Max. °CDB	-20~46			
	Heating	Ambient	Min.~Max. °CWB	-20~15			
Refrigerant	Type/GWP				R-32/675		
	Charge		kg/TCO2Eq		5/3.38		
Piping connections	Liquid/Gas OD		mm		9.52/22.2		
	Piping length	OU - IU	Max. m	100			
	System Chargeless		m		30		
	Additional refrigerant charge		kg/m		See installation manual		
Power supply	Phase/Frequency/Voltage		Hz/V		3~/50 /380-415		
Current - 50Hz	Maximum fuse amps (MFA)		A		20		

Contains fluorinated greenhouse gases

Concealed ceiling unit

Ideal for residential applications with false ceilings

- Combination with split outdoor units is ideal for small retail, offices or residential applications
- Slimmest unit in class, only 245mm (300mm built-in height) and therefore narrow ceiling voids are no longer a challenge
- Low operation sound level down to 25dBA
- Medium external static pressure up to 150Pa facilitates using flexible ducts of varying lengths
- Possibility to change ESP via wired remote control allows optimisation of the supply air volume
- Discretely concealed in the ceiling: only the suction and discharge grilles are visible
- Multi zoning kit allows multiple individually-controlled climate zones to be served by one indoor unit

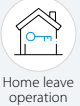
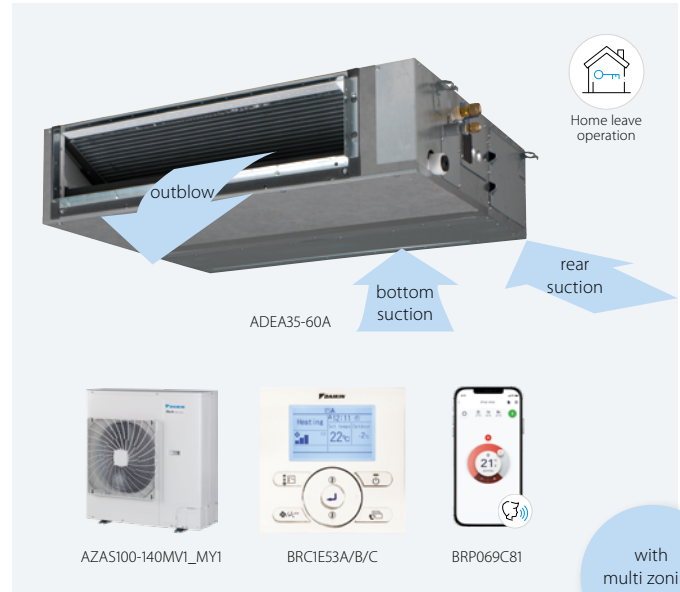

Home leave operation

with multi zoning option

Optimised supply air volume

Automatically selects the most appropriate fan speed to achieve the units' nominal air flow within ±10%

Why?

After installation the real ducting will frequently differ from the initially calculated air flow resistance → the real air flow may be much lower or higher than nominal, leading to a lack of capacity or uncomfortable air temperature. Automatic Airflow Adjustment function will adapt the unit's fan speed to any ducting automatically (10 or more fan curves are available on every model), making installation much faster

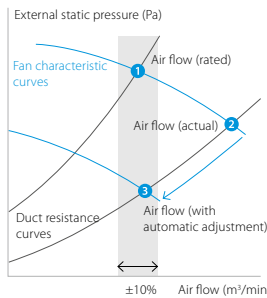

ADEA-A

ARXM-R

AZAS-MV

Efficiency data		ADEA + ARXM/AZAS	71A + ARXM71R	100A + AZAS100MV	125A + AZAS125MV
Cooling capacity	Nom.	kW	6.80/6.98	9.50	12.10
Heating capacity	Nom.	kW	7.50/7.66	10.80	13.50
Space cooling	Energy efficiency class		A	A	-
	Capacity	Pdesign	kW	6.80	12.10
	SEER		5.35	5.13	4.73
	ηs,c		445	-	186
Annual energy consumption		kWh/a	A	648	1,534
Space heating (Average climate)	Energy efficiency class		6.00	A	-
	Capacity	Pdesign	kW	3.80	6.00
	SCOP/A		2,209	3.81	3.50
	ηs,h		%	-	137
Annual energy consumption		kWh/a	2,206	2,206	2,399

Indoor unit		ADEA		71A	100A	125A
Dimensions	Unit	HeightxWidthxDPTH	mm	245x1,000x800	245x1,400x800	
Weight	Unit		kg	35.0	46.0	
Air filter	Type				Resin net	
Fan	Air flow rate	Cooling	Low/Medium/High m³/min	12.5/15.0/18.0	23.0/26.0/29.0	
		Heating	Low/Medium/High m³/min	12.5/15.0/18.0	23.0/26.0/29.0	
	External static pressure	Nom./High	Pa	30/150	40/150	
Sound power level	Cooling		dBA	56	58	
Sound pressure level	Cooling	Low/Medium/High	dBA	25/28/30	30/32/34	
	Heating	Low/Medium/High	dBA	25/28/31	30/33/36	
Control systems	Infrared remote control			BRC4C65 / BRC4C66		
	Wired remote control			BRC1E53A / BRC1E53B / BRC1E53C / BRC1D52		
Power supply	Phase/Frequency/Voltage		Hz/V	1~/50 /220-240/220		

Outdoor unit		ARXM/AZAS		ARXM71R	AZAS100MV	AZAS125MV
Dimensions	Unit	HeightxWidthxDPTH	mm	734x954x401	990x940x320	
Weight	Unit		kg	49.0	72	
Sound power level	Cooling		dBA	-	70	
	Heating		dBA	-	71	
Sound pressure level	Cooling	Nom.	dBA	52.0	53	
	Heating	Nom.	dBA	52.0	57	
Operation range	Cooling	Ambient	Min.~Max.	°CDB	-10 ~46	
	Heating	Ambient	Min.~Max.	°CWB	-15 ~15.5	
Refrigerant	Type/GWP				R-32/675	
	Charge		kg/TCO2Eq	1.15/0.780	2.60/1.76	
Piping connections	Liquid/Gas OD		mm	9.52/15.9		
	Piping length	OU - IU	Max.	m	30	
		System	Equivalent	m	50	
			Chargeless	m	30	
	Additional refrigerant charge		kg/m	0.035 (for piping length exceeding 10m)	See installation manual	
Level difference IU - OU		Max.	m	20.0		
Power supply	Phase/Frequency/Voltage		Hz/V	1~/50 /220-240		
Current - 50Hz	Maximum fuse amps (MFA)		A	-	25	
					32	

Contains fluorinated greenhouse gases

Wall mounted unit

For rooms with no false ceilings nor free floor space

- Combination with Sky Air Alpha-series ensures best in class quality, highest efficiency and performance
- Flat, stylish front panel blends easily within any interior décor and is easier to clean
- Can easily be installed in both new and refurbishment projects
- The air is comfortably spread up- and downwards thanks to 5 different discharge angles that can be programmed via the remote control
- Maintenance operations can be performed easily from the front of the unit
- Flexible to install as the largest casing only weighs 17kg and piping connection can be done at the bottom, left or right of the unit



FAA-B RZAG-NV1 RZAG-NY1

Efficiency data		FAA + RZAG	71B + 71NV1	100B + 100NV1	71B + 71NY1	100B + 100NY1		
Cooling capacity	Nom.	kW	6.80	9.50	6.80	9.50		
Heating capacity	Nom.	kW	7.50	10.80	7.50	10.80		
Space cooling	Energy efficiency class		A++					
	Capacity	Pdesign	kW	6.80	9.50	6.80	9.50	
	SEER			6.58	6.42	6.58	6.42	
	Annual energy consumption		kWh/a	362	518	362	518	
Space heating (Average climate)	Energy efficiency class		A+					
	Capacity	Pdesign	kW	4.70	7.80	4.70	7.80	
	SCOP/A			4.20	4.01	4.20	4.01	
	Annual energy consumption		kWh/a	1,567	2,725	1,567	2,725	
Indoor unit		FAA	71B	100B	71B	100B		
Dimensions	Unit	HeightxWidthxDepth	mm	290x1,050x269	340x1,200x262	290x1,050x269	340x1,200x262	
Weight	Unit		kg	14.0	18	14.0	18	
Fan	Air flow rate	Cooling	Low/Medium/High	m ³ /min	12.1/13.4/16.2	18.7/21.1/23.0	12.1/13.4/16.2	18.7/21.1/23.0
		Heating	Low/Medium/High	m ³ /min	12.7/14.2/16.9	18.7/20.9/23.0	12.7/14.2/16.9	18.7/20.9/23.0
Sound power level	Cooling		dBA	61.0	65.0	61.0	65.0	
	Heating		dBA	61.0	65.0	61.0	65.0	
Sound pressure level	Cooling	Low/Medium/High	dBA	40.0/42.0/45.0	41.0/45.0/49.0	40.0/42.0/45.0	41.0/45.0/49.0	
	Heating	Low/Medium/High	dBA	40.0/42.0/45.0	41.0/45.0/49.0	40.0/42.0/45.0	41.0/45.0/49.0	
Power supply	Phase/Frequency/Voltage		Hz/V	1~/50/220-240				
Outdoor unit		RZAG	71NV1	100NV1	71NY1	100NY1		
Dimensions	Unit	HeightxWidthxDepth	mm	870x1,100x460				
Weight	Unit		kg	81	85	81	85	
Sound power level	Cooling		dBA	64	66	64	66	
Sound pressure level	Cooling	Nom.	dBA	46	47	46	47	
	Heating	Nom.	dBA	48	50	48	50	
Operation range	Cooling	Ambient	Min.~Max.	°CDB				
	Heating	Ambient	Min.~Max.	°CWB				
Refrigerant	Type/GWP			R-32/675				
	Charge		kg/TCO2Eq	3.20/2.16				
Piping connections	Liquid/Gas OD		mm	9.52/15.9				
	Piping length	OU - IU	Max.	m	55	85	55	85
		System	Equivalent	m	75	100	75	100
			Chargeless	m	40			
	Additional refrigerant charge		kg/m	See installation manual				
	Level difference IU - OU		Max.	m				
Power supply	Phase/Frequency/Voltage		Hz/V	1~/50/220-240		3~/50/380-415		
Current - 50Hz	Maximum fuse amps (MFA)		A	20		32	16	

Contains fluorinated greenhouse gases

Wall mounted unit

For rooms with no false ceilings nor free floor space

- Combination with Sky Air Advance-series ensures good value for money for all types of commercial applications
- Flat, stylish front panel blends easily within any interior décor and is easier to clean
- Can easily be installed in both new and refurbishment projects
- The air is comfortably spread up- and downwards thanks to 5 different discharge angles that can be programmed via the remote control
- Maintenance operations can be performed easily from the front of the unit
- Flexible to install as the largest casing only weighs 17kg and piping connection can be done at the bottom, left or right of the unit



		FAA-B	RZASG-MV1	RZASG-MY1	RZASG-MV	RZASG-MY	
Efficiency data		FAA + RZASG	71B + 71MV1	100B + 100MV(1)	100B + 100MY(1)		
Cooling capacity	Nom.	kW	6.80		9.50		
Heating capacity	Nom.	kW	7.50		10.8		
Space cooling	Energy efficiency class		A++		A+		
	Capacity	Pdesign	kW	6.80		9.50	
	SEER			6.41		5.83	
	ηs,c		%		-		
	Annual energy consumption	kWh/a	371		570		
Space heating (Average climate)	Energy efficiency class			A			
	Capacity	Pdesign	kW	4.50		6.00	
	SCOP/A			3.90		3.85	
	ηs,h		%		-		
	Annual energy consumption		kWh/a	1,615		2,182	
Indoor unit		FAA	71B	100B	100B		
Dimensions	Unit	HeightxWidthxDepth	mm	290x1,050x269	340x1,200x262		
Weight	Unit		kg	14.0	18		
Fan	Air flow rate	Cooling	Low/Medium/High	m ³ /min	12.1/13.4/16.2	18.7/21.1/23.0	
		Heating	Low/Medium/High	m ³ /min	12.7/14.2/16.9	18.7/20.9/23.0	
Sound power level	Cooling			dB(A)	61.0	65.0	
	Heating			dB(A)	61.0	65.0	
Sound pressure level	Cooling	Low/Medium/High		dB(A)	40.0/42.0/45.0	41.0/45.0/49.0	
	Heating	Low/Medium/High		dB(A)	40.0/42.0/45.0	41.0/45.0/49.0	
Power supply	Phase/Frequency/Voltage		Hz/V		1~/50 /220-240		
Outdoor unit		RZASG	71MV1	100MV(1)	100MY(1)		
Dimensions	Unit	HeightxWidthxDepth	mm	770x900x320	990x940x320		
Weight	Unit		kg	60	70 (MV1/MY1)/72 (MV/MY)		
Sound power level	Cooling			dB(A)	65	70	
Sound pressure level	Cooling	Nom.		dB(A)	46	53	
	Heating	Nom.		dB(A)	47	57	
Operation range	Cooling	Ambient	Min.~Max.	°CDB	-15~-46		
	Heating	Ambient	Min.~Max.	°CWB	-15~-15.5		
Refrigerant	Type/GWP				R-32/675		
	Charge		kg/TCO2Eq	2.45/1.65		2.60/1.76	
Piping connections	Liquid/ Gas	OD		mm	9.52/15.9		
	Piping length	OU - IU	Max.	m	50		
		System	Equivalent		m	70	
			Chargeless		m	30	
	Additional refrigerant charge			kg/m	See installation manual		
Level difference	IU - OU	Max.		m	30.0		
Power supply	Phase/Frequency/Voltage		Hz/V	1~/50 /220-240		3~/50 /380-415	
Current - 50Hz	Maximum fuse amps (MFA)		A	20	25	16	

Contains fluorinated greenhouse gases

Wall mounted unit

For rooms with no false ceilings nor free floor space

- Ideal solution for small businesses and shops
- Flat, stylish front panel blends easily within any interior décor and is easier to clean
- Can easily be installed in both new and refurbishment projects
- The air is comfortably spread up- and downwards thanks to 5 different discharge angles that can be programmed via the remote control
- Maintenance operations can be performed easily from the front of the unit
- Flexible to install as the largest casing only weighs 17kg and piping connection can be done at the bottom, left or right of the unit



FAA-B ARXM-R AZAS-MV AZAS-MY

Efficiency data		FAA + ARXM/AZAS		71B + ARXM71R	100B + AZAS100MV	100B + AZAS100MY	
Cooling capacity	Nom./Max.	kW		6.80/6.95		9.50 /-	
Heating capacity	Nom./Max.	kW		7.50/7.59		10.8 /-	
Space cooling	Energy efficiency class			A+		A	
	Capacity	Pdesign	kW	6.80		9.50	
	SEER			5.77		5.25	
	Annual energy consumption		kWh/a	412		633	
Space heating (Average climate)	Energy efficiency class				A		
	Capacity	Pdesign	kW	4.50		6.00	
	SCOP/A			3.81		3.81	
	Annual energy consumption		kWh/a	1,652		2,205	
Indoor unit		FAA		71B	100B	100B	
Dimensions	Unit	HeightxWidthxD	Depth	mm	290x1,050x269	340x1,200x262	
Weight	Unit			kg	14.0	18	
Fan	Air flow rate	Cooling	Low/Medium/High	m ³ /min	12.1/13.4/16.2	18.7/21.1/23.0	
		Heating	Low/Medium/High	m ³ /min	12.7/14.2/16.9	18.7/20.9/23.0	
Sound power level	Cooling			dB(A)	61.0	65.0	
	Heating			dB(A)	61.0	65.0	
Sound pressure level	Cooling	Low/Medium/High		dB(A)	40.0/42.0/45.0	41.0/45.0/49.0	
	Heating	Low/Medium/High		dB(A)	40.0/42.0/45.0	41.0/45.0/49.0	
Power supply	Phase/Frequency/Voltage			Hz/V	1~/50 /220-240	1~/50 /220-240	
Outdoor unit		ARXM/AZAS		ARXM71R	AZAS100MV	AZAS100MY	
Dimensions	Unit	HeightxWidthxD	Depth	mm	734x954x401	990x940x320	
Weight	Unit			kg	49.0	72	
Sound power level	Cooling			dB(A)	-	70	
Sound pressure level	Cooling	Nom.		dB(A)	52.0	53	
	Heating	Nom.		dB(A)	52.0	57	
Operation range	Cooling	Ambient	Min.~Max.	°CDB		-10~46	
	Heating	Ambient	Min.~Max.	°CWB	-15~24	-15~15.5	
Refrigerant	Type/GWP				R-32/675		
	Charge			kg/TCO2Eq	1.15/0.780	2.60/1.76	
Piping connections	Liquid/ Gas	OD		mm		9.52/15.9	
	Piping length	OU - IU	Max.	m		30	
		System	Equivalent	m	-		50
			Chargeless	m	-		30
	Additional refrigerant charge				kg/m	0.035 (for piping length exceeding 10m)	See installation manual
Level difference	IU - OU	Max.		m	20.0	30.0	
Power supply	Phase/Frequency/Voltage			Hz/V	1~/50 /220-240	3~/50 /380-415	
Current - 50Hz	Maximum fuse amps (MFA)			A	-	25	
						16	

Contains fluorinated greenhouse gases

Wall mounted unit

Attractive, wall mounted design with perfect indoor air quality

- Combination with Sky Air Alpha-series ensures best in class quality, highest efficiency and performance
- Seasonal efficiency values up to A+++ in cooling and heating
- Practically inaudible: the unit runs so quietly, you will almost forget it is there
- Cleaner air thanks to Daikin's Flash Streamer technology: you can breathe deep with no worries about impure air
- 2-area motion detection sensor: air flow is sent to a zone other than where the person is located at that moment; if no people are detected, the unit will automatically switch over to the energy-efficient setting. (larger capacity area)
- Onecta app: control your indoor from any location with an app, via your local network or internet
- Sleek, unobtrusive air conditioning unit that matches European sensibilities regarding interior design
- 3-D air flow combines vertical and horizontal auto swing to circulate a stream of warm or cool air right to the corners of even large spaces



FTXM-R

RZAG-A

Efficiency data		FTXM + RZAG		35R + 35A		50R + 50A		60R + 60A		
Cooling capacity	Min./Nom./Max.	kW		1.6/3.5/5.0		1.7/5.0/6.0		1.7/6.0/6.8		
Heating capacity	Min./Nom./Max.	kW		1.40/4.00/5.30		1.50/6.00/6.50		1.60/7.00/7.50		
Space cooling	Energy efficiency class					A++				
	Capacity	Pdesign	kW	3.50		5.00		6.00		
	SEER			7.70		7.41		6.90		
	Annual energy consumption			kWh/a		159		236		
Space heating (Average climate)	Energy efficiency class					A++		A+		
	Capacity	Pdesign	kW	2.60		4.50		4.60		
	SCOP/A					4.60		4.35		
	Annual energy consumption			kWh/a		790		1,369		
Indoor unit		FTXM		35R		50R		60R		
Dimensions	Unit	HeightxWidthxDepth		mm		295x778x272		299x998x292		
Weight	Unit			kg		10.0		14.5		
Air filter	Type						Removable/washable			
Fan	Air flow rate	Cooling	Silent operation/ Low/Medium/High	m ³ /min	4.2/6.0/7.8/11.3		8.3/11.4/14/15.8		9.1/11.8/14/16.7	
		Heating	Silent operation/ Low/Medium/High	m ³ /min	4.9/6.5/8.5/9.8		10.5/12.0/14.2/15.8		11.1/12.4/15.2/16.5	
Sound power level	Cooling			dB(A)	58		58.0		60.0	
	Heating			dB(A)	54		58.0		59.0	
Sound pressure level	Cooling	Silent operation/Low/High		dB(A)	19/29/45		27.0/36.0/44.0		30.0/37.0/46.0	
	Heating	Silent operation/Low/High		dB(A)	20/28/39		31.0/34.0/43.0		33.0/36.0/45.0	
Control systems	Infrared remote control					ARC466A67				
	Wired remote control					BRC073A1				
Outdoor unit		RZAG		35A		50A		60A		
Dimensions	Unit	HeightxWidthxDepth		mm		734x870x373				
Weight	Unit			kg		52				
Sound power level	Cooling			dB(A)	62.0		63.0		64.0	
	Heating			dB(A)	62.0		63.0		64.0	
Sound pressure level	Cooling	Nom.		dB(A)	48.0		49.0		50.0	
	Heating	Nom.		dB(A)	48.0		49.0		50.0	
Operation range	Cooling	Ambient	Min.~Max.	°CDB			-20~-52			
	Heating	Ambient	Min.~Max.	°CWB			-20~-24			
Refrigerant	Type/GWP					R-32/675.0				
	Charge			kg/TCO2Eq		1.55/1.05				
Piping connections	OD				mm	6.35/9.52		6.35/12.7		
	Piping length	OU - IU	Max.		m			50		
		System	Chargeless		m			30		
	Additional refrigerant charge			kg/m		0.02 (for piping length exceeding 30m)				
	Level difference IU - OU		Max.		m			30.0		
Power supply	Phase/Frequency/Voltage				Hz/V			1~/50/220-240		

Contains fluorinated greenhouse gases

Ceiling suspended unit

For wide rooms with no false ceilings nor free floor space

- Combining with Sky Air Advance-series ensures good value for money for all types of commercial applications
- Ideal for comfortable air flow in wide rooms thanks to Coanda effect: up to 100° discharge angle

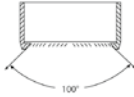

- Even rooms with ceilings up to 3.8m can be heated up or cooled down very easily without capacity loss
- Can easily be installed in both new and refurbishment projects
- Can easily be mounted in corners and narrow spaces, as it only needs 30mm lateral service space

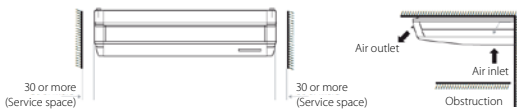

- Reduced energy consumption thanks to specially developed DC fan motor
- 5 different fan speeds available for maximum comfort



Home leave operation



Vertical auto swing

FHA60-71A9

RZAG35-60A

BRC1H52W, BRP069A81

FHA-A(9) RZAG-A RZAG-NV1 RZAG-NY1

Efficiency data		FHA + RZAG		35A9+35A	50A9+50A	60A9+60A	71A9+71NV1	100A+100NV1	125A+125NV1	140A+140NV1	71A9+71NY1	100A+100NY1	125A+125NY1	140A+140NY1			
Cooling capacity	Min./Nom./Max.	kW		1.70/3.50/4.50	1.70/5.00/6.00	1.90/6.00/6.80	-/6.80/-	-/9.50/-	-/12.1/-	-/13.4/-	-/6.80/-	-/9.50/-	-/12.1/-	-/13.4/-			
Heating capacity	Min./Nom./Max.	kW		1.40/4.00/5.50	1.70/5.80/6.50	1.70/7.00/7.50	-/7.50/-	-/10.8/-	-/13.5/-	-/15.5/-	-/7.50/-	-/10.8/-	-/13.5/-	-/15.5/-			
Space cooling	Energy efficiency class			A++				-		A++							
	Capacity	Pdesign	kW	3.50	5.00	6.00	6.80	9.50	12.1	13.4	6.80	9.50	12.1	13.4			
	SEER			6.40	6.80	6.60	7.11	6.42	7.14	6.42	7.11	6.42	7.14	6.42			
	ηs,c	%		-				283		254		-		283		254	
	Annual energy consumption	kWh/a		191	257	318	335	518	1,017	1,253	335	518	1,017	1,253			
Space heating (Average climate)	Energy efficiency class			A+				A++		-		A+		A++		-	
	Capacity	Pdesign	kW	3.10	4.00	4.60	4.70	7.80	9.52		4.70	7.80	9.52				
	SCOP/A			4.10	4.30	4.20	4.32	4.61	4.20	4.30	4.32	4.61	4.20	4.30			
	ηs,h	%		-				165		169		-		165		169	
	Annual energy consumption	kWh/a		1,058	1,302	1,633	1,523	2,369	3,174	3,100	1,523	2,369	3,174	3,100			
Indoor unit		FHA		35A9	50A9	60A9	71A9	100A	125A	140A	71A9	100A	125A	140A			
Dimensions	Unit	HeightxWidthxDepth	mm	235x960x690			235x1,270x690		235x1,590x690			235x1,270x690			235x1,590x690		
Weight	Unit		kg	26	27	32	34	41			34	41					
Air filter	Type	Resinnet															
Fan	Air flow rate	Cooling	Low/Medium/High	m³/min	10.0/11.5/14.0	10.0/12.0/15.0	11.5/15.0/19.5	14.0/17.0/20.5	20.0/24.0/28.0	23.0/27.0/31.0	24.0/29.0/34.0	14.0/17.0/20.5	20.0/24.0/28.0	23.0/27.0/31.0	24.0/29.0/34.0		
	Heating	Low/Medium/High	m³/min	10.0/11.5/14.0	10.0/12.0/15.0	11.5/15.0/19.5	14.0/17.0/20.5	20.0/24.0/28.0	23.0/27.0/31.0	24.0/29.0/34.0	14.0/17.0/20.5	20.0/24.0/28.0	23.0/27.0/31.0	24.0/29.0/34.0			
Sound power level	Cooling			dBA	53.0	54.0	55.0	60.0	62.0	64.0	55.0	60.0	62.0	64.0			
	Heating			dBA	53.0	54.0	55.0	60.0	62.0	64.0	55.0	60.0	62.0	64.0			
Sound pressure level	Cooling	Low/High		dBA	31.0/36.0	32.0/37.0	33.0/37.0	34.0/38.0	34.0/42.0	37.0/44.0	38.0/46.0	34.0/38.0	34.0/42.0	37.0/44.0	38.0/46.0		
	Heating	Nom./High		dBA	34.0/36.0	35.0/37.0	36.0/38.0	38.0/42.0	41.0/44.0	42.0/46.0	36.0/38.0	38.0/42.0	41.0/44.0	42.0/46.0			
Control systems	Infrared remote control	BRC7GA53-9 / BRC7GA56															
	Wired remote control	BRC1D528 / BRC1H51(9)W/S/K7 / BRC1H52W/S/K / BRC1H81W7 / BRC1H81S7 / BRC1E53A/B/C7 / BRC1H82W/S/K															
Power supply	Phase/Frequency/Voltage	Hz/V	1~/50/60/220-240/220														
Piping connections	Drain		VP20														
Outdoor unit		RZAG		35A	50A	60A	71NV1	100NV1	125NV1	140NV1	71NY1	100NY1	125NY1	140NY1			
Dimensions	Unit	HeightxWidthxDepth	mm	734x870x373			870x1,100x460										
Weight	Unit		kg	52			81	85	95			81	85	94			
Sound power level	Cooling		dBA	62.0	63.0	64.0	64	66	69	70	64	66	69	70			
	Heating		dBA	62.0	63.0	64.0	-	-	68	71	-	-	68	71			
Sound pressure level	Cooling	Nom.	dBA	48.0	49.0	50.0	46	47	49	50	46	47	49	50			
	Heating	Nom.	dBA	48.0	49.0	50.0	48	50	52	52	48	50	52				
Operation range	Cooling	Ambient	Min.~Max.	°CDB			-20 ~ 52			-20 ~ 52							
	Heating	Ambient	Min.~Max.	°CWB			-20 ~ 24			-20 ~ 18							
Refrigerant	Type/GWP	R-32/675.0															
	Charge	kg/TCO2Eq	1.55/1.05			3.20/2.16		3.70/2.50			3.20/2.16		3.70/2.50				
Piping connections	Liquid/Gas	OD	mm	6.35/9.50			6.35/12.7			10/15.9							
	Piping length	OU - IU	Max.	m			50		55		85		55		85		
		System	Equivalent	m			-		75		100		75		100		
			Chargeless	m			30			40							
		Level difference	IU - OU	Max.	m			30.0			30						
	Additional refrigerant charge	kg/m	0.02 (for piping length exceeding 30m)			See installation manual											
Power supply	Phase/Frequency/Voltage	Hz/V	1~/50 / 220-240			3~/50 / 380-415											
Current - 50Hz	Maximum fuse amps (MFA)	A	-			20		32			16						

Contains fluorinated greenhouse gases

Ceiling suspended unit

For wide rooms with no false ceilings nor free floor space

- Combination with Sky Air Advance-series ensures good value for money for all types of commercial applications
- Ideal for comfortable air flow in wide rooms thanks to Coanda effect: up to 100° discharge angle
- Even rooms with ceilings up to 3.8m can be heated up or cooled down very easily without capacity loss
- Can easily be installed in both new and refurbishment projects
- Can easily be mounted in corners and narrow spaces, as it only needs 30mm lateral service space
- 5 different fan speeds available for maximum comfort
- Stylish unit blends easily with any interior. The flaps close entirely when the unit is not operating and there are no air intake grilles visible



FHA-A(9) RZASG-MV1 RZASG-MY1 RZASG-MV RZASG-MY

Efficiency data		FHA + RZASG 71A9 + 71MV1		100A + 100MV(1)	125A + 125MV(1)	140A + 140MV(1)	100A + 100MY(1)	125A + 125MY(1)	140A + 140MY(1)								
Cooling capacity	Nom.	kW		6.80	9.50	12.1	9.50	12.1	13.4								
Heating capacity	Nom.	kW		7.50	10.8	13.5	10.8	13.5	15.5								
Space cooling	Energy efficiency class		A+		-		A+		-								
	Capacity	Pdesign	kW		6.80	9.50	12.1	9.50	12.1	13.4							
	SEER		5.95		5.83		5.83		5.88								
	ηs,c	%		-		230		-		230							
Annual energy consumption		kWh/a		400	570	1,246	570	1,246	1,368								
Space heating (Average climate)	Energy efficiency class		A		-		A		-								
	Capacity	Pdesign	kW		4.50	6.00	7.80	6.00	7.80								
	SCOP/A		3.90		3.91		3.81		3.81								
	ηs,h	%		-		150		-		149							
Annual energy consumption		kWh/a		1,616	2,148	2,193	2,148	2,193	2,866								
Indoor unit		FHA 71A9		100A	125A	140A	100A	125A	140A								
Dimensions	Unit	HeightxWidthxDepth		mm		235x1,270x690		235x1,590x690									
Weight	Unit	kg		34		41											
Air filter	Type		Resin net														
Fan	Air flow rate	Cooling	Low/Medium/High	m³/min	14.0/17.0/20.5	20.0/24.0/28.0	23.0/27.0/31.0	24.0/29.0/34.0	20.0/24.0/28.0	23.0/27.0/31.0	24.0/29.0/34.0						
		Heating	Low/Medium/High	m³/min	14.0/17.0/20.5	20.0/24.0/28.0	23.0/27.0/31.0	24.0/29.0/34.0	20.0/24.0/28.0	23.0/27.0/31.0	24.0/29.0/34.0						
Sound power level	Cooling	dBA		55.0	60.0	62.0	64.0	60.0	62.0	64.0							
	Heating	dBA		55.0	60.0	62.0	64.0	60.0	62.0	64.0							
Sound pressure level	Cooling	Low/High	dBA		34.0/38.0	34.0/42.0	37.0/44.0	38.0/46.0	34.0/42.0	37.0/44.0	38.0/46.0						
	Heating	Nom./High	dBA		36.0/38.0	38.0/42.0	41.0/44.0	42.0/46.0	38.0/42.0	41.0/44.0	42.0/46.0						
Control systems	Infrared remote control		BRC7GA53-9 / BRC7GA56														
	Wired remote control		BRC1H52W/S/K; BRC1E53A; BRC1E53B; BRC1E53C; BRC1D52														
Power supply	Phase/Frequency/Voltage		Hz/V		1~/50/60/220-240/220												
Piping connections	Drain		VP20														
Outdoor unit		RZASG 71MV1		100MV(1)	125MV(1)	140MV(1)	100MY(1)	125MY(1)	140MY(1)								
Dimensions	Unit	HeightxWidthxDepth		mm		770x900x320		990x940x320									
Weight	Unit	kg		60		70 (MY1)/72 (MY)		78 (MV1)/79 (MV)		70 (MY1)/72 (MY)		78 (MV1)/79 (MV)					
Sound power level	Cooling	dBA		65		70		71		73		70		71		73	
	Heating	dBA		-		71		73		-		71		73			
Sound pressure level	Cooling	Nom.	dBA		46		53		54		53		54				
	Heating	Nom.	dBA		47		57		57		57		57				
Operation range	Cooling	Ambient	Min.~Max.	°CDB		-		-15~46		-		-15~15.5					
	Heating	Ambient	Min.~Max.	°CWB		-		-		-		-					
Refrigerant	Type/GWP		R-32/675														
	Charge	kg/TCO2Eq		2.45/1.65		2.60/1.76		2.90/1.96		2.60/1.76		2.90/1.96					
Piping connections	Liquid/ Gas	OD		mm		9.52/15.9		9.52/15.9		9.52/15.9		9.52/15.9					
	Piping length	OU - IU	Max.	m		50		50		50		50					
		System	Equivalent	m		70		70		70		70					
			Chargeless	m		30		30		30		30					
		Level difference	IU - OU	Max.	m		30.0		30.0		30.0		30.0				
	Additional refrigerant charge		kg/m		See installation manual												
Power supply	Phase/Frequency/Voltage		Hz/V		1~/50 /220-240				3~/50 /380-415								
Current - 50Hz	Maximum fuse amps (MFA)		A		20		25		32		16						

Contains fluorinated greenhouse gases

Ceiling suspended unit

For wide rooms with no false ceilings nor free floor space

- Ideal solution for small businesses and shops
- Ideal for comfortable air flow in wide rooms thanks to Coanda effect: up to 100° discharge angle
- Even rooms with ceilings up to 3.8m can be heated up or cooled down very easily without capacity loss
- Can easily be installed in both new and refurbishment projects
- Can easily be mounted in corners and narrow spaces, as it only needs 30mm lateral service space
- 5 different fan speeds available for maximum comfort
- Stylish unit blends easily with any interior. The flaps close entirely when the unit is not operating and there are no air intake grilles visible



FHA-A(9) AZAS-MV AZAS-MY

Efficiency data		FHA + AZAS	100A + 100MV	125A + 125MV	140A + 140MV	100A + 100MY	125A + 125MY	140A + 140MY		
Cooling capacity	Nom.	kW	9.50	12.1	13.4	9.50	12.1	13.4		
Heating capacity	Nom.	kW	10.8	13.5	15.5	10.8	13.5	15.5		
Space cooling	Energy efficiency class		A			A				
	Capacity	Pdesign	kW	9.50	12.1	13.4	9.50	12.1	13.4	
	SEER		5.6							
	ηs,c	%	-			221				
Space heating (Average climate)	Annual energy consumption		kWh/a	594	1,297	1,436	594	1,297	1,436	
	Energy efficiency class		A			A				
	Capacity	Pdesign	kW	6.00	7.80	6.00	7.80	7.80		
	SCOP/A		3.87		3.75	3.81	3.87	3.75	3.81	
	ηs,h	%	-		147	149	-	147	149	
Annual energy consumption		kWh/a	2,171	2,240	2,866	2,171	2,240	2,866		
Indoor unit		FHA	100A	125A	140A	100A	125A	140A		
Dimensions	Unit	HeightxWidthxDp	mm							
Weight	Unit		kg							
Air filter	Type		Resin net							
Fan	Air flow rate	Cooling	Low/Medium/High	m³/min	20.0/24.0/28.0	23.0/27.0/31.0	24.0/29.0/34.0	20.0/24.0/28.0	23.0/27.0/31.0	24.0/29.0/34.0
		Heating	Low/Medium/High	m³/min	20.0/24.0/28.0	23.0/27.0/31.0	24.0/29.0/34.0	20.0/24.0/28.0	23.0/27.0/31.0	24.0/29.0/34.0
Sound power level	Cooling		dBA	60.0	62.0	64.0	60.0	62.0	64.0	
	Heating		dBA	60.0	62.0	64.0	60.0	62.0	64.0	
Sound pressure level	Cooling	Low/High	dBA	34.0/42.0	37.0/44.0	38.0/46.0	34.0/42.0	37.0/44.0	38.0/46.0	
	Heating	Nom./High	dBA	38.0/42.0	41.0/44.0	42.0/46.0	38.0/42.0	41.0/44.0	42.0/46.0	
Control systems	Infrared remote control		BRC7GA53-9 / BRC7GA56							
	Wired remote control		RC1H52W/S/K; BRC1E53A; BRC1E53B; BRC1E53C; BRC1D52							
Power supply	Phase/Frequency/Voltage		Hz/V							
Piping connections	Drain		VP20							
Outdoor Unit		AZAS100MV	AZAS125MV	AZAS140MV	AZAS100MY	AZAS125MY	AZAS140MY			
Dimensions	Unit	HeightxWidthxDp	mm							
Weight	Unit		kg							
Sound power level	Cooling		dBA	70	71	72	70	71	72	
	Heating		dBA	70	71	72	70	71	72	
Sound pressure level	Cooling	Nom.	dBA	53	54	55	53	54	55	
	Heating	Nom.	dBA	57	58	59	57	58	59	
Operation range	Cooling	Ambient	Min.~Max.	°CDB						
	Heating	Ambient	Min.~Max.	°CWB						
Refrigerant	Type/GWP		R-32/675							
	Charge		kg/TCO2Eq	2.60/1.76	2.90/1.96	2.60/1.76	2.90/1.96			
Piping connections	Liquid/Gas OD		mm							
	Piping length	OU - IU	Max.	m						
	Chargeless	System Equivalent		m						
		Chargeless		m						
	Additional refrigerant charge		kg/m	See installation manual						
Power supply	Phase/Frequency/Voltage		1~/50/220-240			3~/50/380-415				
Current - 50Hz	Maximum fuse amps (MFA)		A	25	32	25	32	16		

Contains fluorinated greenhouse gases

Ceiling suspended unit

For wide rooms with no false ceilings nor free floor space

- Combination with split outdoor units is ideal for small retail, offices and residential applications
- Ideal for comfortable air flow in wide rooms thanks to Coanda effect: up to 100° discharge angle
- Even rooms with ceilings up to 3.8m can be heated up or cooled down very easily without capacity loss
- Can easily be installed in both new and refurbishment projects
- Can easily be mounted in corners and narrow spaces, as it only needs 30mm lateral service space
- 5 different fan speeds available for maximum comfort
- Stylish unit blends easily with any interior. The flaps close entirely when the unit is not operating and there are no air intake grilles visible



FHA-A(9) RXM-R RXM-R9 RXM-A

Efficiency data		FHA + RXM		35A9 + 35R9		50A9 + 50A		60A9 + 60R	
Cooling capacity	Nom.	kW		3.40		5.00		5.70	
Heating capacity	Nom.	kW		4.00		6.00		7.20	
Space cooling	Energy efficiency class			A++		A+			
	Capacity	Pdesign		kW		3.40		5.70	
	SEER			6.24		5.92		6.08	
	Annual energy consumption			kWh/a		191		295	
Space heating (Average climate)	Energy efficiency class			A+		A			
	Capacity	Pdesign		kW		3.10		4.35	
	SCOP/A			4.43		3.86		3.87	
	Annual energy consumption			kWh/a		979		1,577	
Indoor unit		FHA		35A9		50A9		60A9	
Dimensions	Unit	HeightxWidthxDensity		mm		235x960x690		235x1,270x690	
Weight	Unit	kg		26		27		32	
Air filter	Type	Resin net		Resin net		Resin net		Resin net	
Fan	Air flow rate	Cooling	Low/Medium/High	m ³ /min		10.0/11.5/14.0		10.0/12.0/15.0	
		Heating	Low/Medium/High	m ³ /min		10.0/11.5/14.0		10.0/12.0/15.0	
Sound power level	Cooling	dBA		53.0		54.0		54.0	
	Heating	dBA		53.0		54.0		54.0	
Sound pressure level	Cooling	Low/Medium/High		dBA		31.0/34.0/36.0		32.0/35.0/37.0	
	Heating	Medium/Nom./High		dBA		31.0/34.0/36.0		32.0/35.0/37.0	
Control systems	Infrared remote control			BRC7GA53-9 / BRC7GA56		BRC7GA53-9 / BRC7GA56		BRC7GA53-9 / BRC7GA56	
	Wired remote control			BRC1H52W/S/K / BRC1E53A/B/C / BRC1D52		BRC1H52W/S/K / BRC1E53A/B/C / BRC1D52		BRC1H52W/S/K / BRC1E53A/B/C / BRC1D52	
Power supply	Phase/Frequency/Voltage		Hz/V		1~/50/60/220-240/220		1~/50/60/220-240/220		

Outdoor unit		RXM		35R9		50A		60R	
Dimensions	Unit	HeightxWidthxDensity		mm		552x840x350		734x954x401	
Weight	Unit	kg		32		49.0		49.0	
Sound pressure level	Cooling	Nom.		dBA		49.0		48.0	
	Heating	Nom.		dBA		49.0		48.0	
Operation range	Cooling	Ambient	Min.~Max.	°CDB		-10 ~ 46		-10 ~ 46	
	Heating	Ambient	Min.~Max.	°CWB		-15 ~ 18		-15 ~ 18	
Refrigerant	Type	R-32		R-32		R-32		R-32	
	GWP	675.0		675.0		675.0		675.0	
	Charge	kg/TCO2Eq		0.76/0.52		1.15/0.780		1.15/0.780	
Piping connections	Liquid	OD		mm		6.35		6.35	
	Gas	OD		mm		9.52		12.7	
	Piping length	OU - IU	Max.	m		20		30	
	Additional refrigerant charge	System	Chargeless	m		10		10	
	Level difference	IU - OU	Max.	m		15		20.0	
Power supply	Phase/Frequency/Voltage		Hz/V		1~/50 / 220-240		1~/50 / 220-240		
Current - 50Hz	Maximum fuse amps (MFA)		A		13		16		

Contains fluorinated greenhouse gases

4-way blow ceiling suspended unit

Unique Daikin unit for high rooms with no false ceilings nor free floor space

- Combining with Sky Air Advance-series ensures good value for money for all types of commercial applications
- Even rooms with ceilings up to 3.5m can be heated up or cooled down very easily without capacity loss
- Can easily be installed in both new and refurbishment projects
- Two optional intelligent sensors improve energy efficiency and comfort
- Unified indoor unit range for R-32 and R-410A
- Individual flap control: flexibility to suit every room layout without changing the location of the unit!

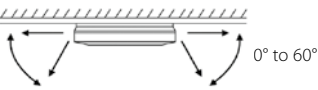

- 5 different discharge angles between 0 and 60° can be programmed via the remote control
- Stylish modern casing finished in pure white (RAL9010) and iron grey (RAL7011) blends easily with any interior



- Optimum comfort guaranteed with automatic air flow adjustment to the required load
- Standard drain pump with 720mm lift increases flexibility and installation speed

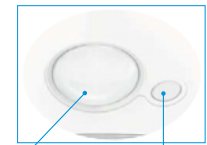
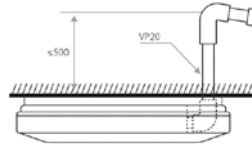

presence sensor floor sensor

FUA-A RZAG-NV1 RZAG-NY1

Efficiency data			FUA + RZAG	71A + 71NV1	100A + 100NV1	125A + 125NV1	71A + 71NY1	100A + 100NY1	125A + 125NY1	
Cooling capacity	Nom.		kW	6.80	9.50	12.1	6.80	9.50	12.1	
Heating capacity	Nom.		kW	7.50	10.8	13.5	7.50	10.8	13.5	
Space cooling	Energy efficiency class			A++		-	A++		-	
	Capacity	Pdesign	kW	6.80	9.50	12.1	6.80	9.50	12.1	
	SEER			7.02	6.42	6.39	7.02	6.42	6.39	
	$\eta_{s,c}$		%	-	-	253	-	-	253	
	Annual energy consumption		kWh/a	339	518	1,136	339	518	1,136	
Space heating (Average climate)	Energy efficiency class			A+		-	A+		-	
	Capacity	Pdesign	kW	4.70	7.80	9.52	4.70	7.80	9.52	
	SCOP/A			4.20	4.50	4.26	4.20	4.50	4.26	
	$\eta_{s,h}$		%	-	-	167	-	-	167	
	Annual energy consumption		kWh/a	1,567	2,427	3,129	1,567	2,427	3,129	
Indoor unit			FUA	71A	100A	125A	71A	100A	125A	
Dimensions	Unit	HeightxWidthxDepth	mm	198x950x950						
Weight	Unit		kg	25.0	26.0		25.0	26.0		
Air filter	Type			Resinnet						
Fan	Air flow rate	Cooling	Low/Medium/High	m ³ /min	16.0/19.5/23.0	20.0/25.5/31.0	20.5/26.5/32.5	16.0/19.5/23.0	20.0/25.5/31.0	20.5/26.5/32.5
		Heating	Low/Medium/High	m ³ /min	16.0/19.5/23.0	20.0/25.5/31.0	20.5/26.5/32.5	16.0/19.5/23.0	20.0/25.5/31.0	20.5/26.5/32.5
Sound power level	Cooling			dBA	59	64	65	59	64	65
Sound pressure level	Cooling	Low/High		dBA	35/41	39/46	40/47	35/41	39/46	40/47
	Heating	Low/High		dBA	35/41	39/46	40/47	35/41	39/46	40/47
Control systems	Wired remote control			BRC1H52W/S/K / BRC1E53A/B/C / BRC1D52						
Piping connections	Drain			VP25 (OD Ø32.0)						
Outdoor unit			RZAG	71NV1	100NV1	125NV1	71NY1	100NY1	125NY1	
Dimensions	Unit	HeightxWidthxDepth	mm	870x1,100x460						
Weight	Unit		kg	81	85	95	81	85	94	
Sound power level	Cooling			dBA	64	66	69	64	66	69
	Heating			dBA	-	-	68	-	-	68
Sound pressure level	Cooling	Nom.		dBA	46	47	49	46	47	49
	Heating	Nom.		dBA	48	50	52	48	50	52
Operation range	Cooling	Ambient	Min.~Max.	°CDB	-20 ~52					
	Heating	Ambient	Min.~Max.	°CWB	-20 ~18					
Refrigerant	Type/GWP			R-32/675						
	Charge		kg/TCO ₂ Eq	3.20/2.16		3.70/2.50		3.20/2.16		3.70/2.50
Piping connections	Liquid/Gas OD			9.52/15.9						
	Piping length	OU - IU	Max.	m	55	85		55	85	
		System	Equivalent	m	75	100		75	100	
			Chargeless	m	40					
		Level difference IU - OU	Max.	m	30					
	Additional refrigerant charge		kg/m	See installation manual						
Power supply	Phase/Frequency/Voltage		Hz/V	1~/50 /220-240			3~/50 /380-415			
Current - 50Hz	Maximum fuse amps (MFA)		A	20	32		16			

Contains fluorinated greenhouse gases

4-way blow ceiling suspended unit

Unique Daikin unit for high rooms with no false ceilings nor free floor space

- Combination with Sky Air Advance-series ensures good value for money for all types of commercial applications
- Even rooms with ceilings up to 3.5m can be heated up or cooled down very easily without capacity loss
- Can easily be installed in both new and refurbishment projects
- Individual flap control: flexibility to suit every room layout without changing the location of the unit!
- 5 different discharge angles between 0 and 60° can be programmed via the remote control
- Stylish modern casing finished in pure white (RAL9010) and iron grey (RAL7011) blends easily with any interior
- Optimum comfort guaranteed with automatic air flow adjustment to the required load
- Standard drain pump with 720mm lift increases flexibility and installation speed



FUA-A RZASG-MV1 RZASG-MY1 RZASG-MV RZASG-MY

Efficiency data		FUA + RZASG	71A + 71MV1	100A + 100MV(1)	125A + 125MV(1)	100A + 100MY(1)	125A + 125MY(1)	
Cooling capacity	Nom.	kW	6.80	9.50	12.1	9.50	12.1	
Heating capacity	Nom.	kW	7.50	10.8	13.5	10.8	13.5	
Space cooling	Energy efficiency class		A++	A+	-	A+	-	
	Capacity	Pdesign	kW	6.80	9.50	12.1	9.50	12.1
	SEER		6.16	5.83	5.49	5.83	5.49	
	ηs,c	%	-	-	217	-	217	
	Annual energy consumption	kWh/a	386	570	1,322	570	1,322	
Space heating (Average climate)	Energy efficiency class		A	A+	-	A+	-	
	Capacity	Pdesign	kW	4.50		6.00		
	SCOP/A		3.90	4.01	3.84	4.01	3.84	
	ηs,h	%	-	-	151	-	151	
	Annual energy consumption	kWh/a	1,615	2,095	2,188	2,095	2,188	
Indoor unit		FUA	71A	100A	125A	100A	125A	
Dimensions	Unit	HeightxWidthxDpeth	mm	198x950x950				
Weight	Unit	kg	25.0	26.0				
Air filter	Type		Resinnet					
Fan	Air flow rate	Cooling	Low/Medium/High m³/min	16.0/19.5/23.0	20.0/25.5/31.0	20.5/26.5/32.5	20.0/25.5/31.0	20.5/26.5/32.5
		Heating	Low/Medium/High m³/min	16.0/19.5/23.0	20.0/25.5/31.0	20.5/26.5/32.5	20.0/25.5/31.0	20.5/26.5/32.5
Sound power level	Cooling		dBA	59	64	65	64	65
Sound pressure level	Cooling	Low/High	dBA	35/41	39/46	40/47	39/46	40/47
	Heating	Low/High	dBA	35/41	39/46	40/47	39/46	40/47
Control systems	Wired remote control		BRC1H52W/S/K; BRC1E53A; BRC1E53B; BRC1E53C; BRC1D52					
Piping connections	Drain		VP25 (OD Ø32.0)					
Outdoor unit		RZASG	71MV1	100MV(1)	125MV(1)	100MY(1)	125MY(1)	
Dimensions	Unit	HeightxWidthxDpeth	mm	770x900x320	990x940x320			
Weight	Unit	kg	60	70 (MV1/MY1)/72 (MV/MY)				
Sound power level	Cooling		dBA	65	69	71	69	71
	Heating		dBA	-	-	-	-	-
Sound pressure level	Cooling	Nom.	dBA	46	53	54	53	54
	Heating	Nom.	dBA	47	57	58	57	58
Operation range	Cooling	Ambient	Min.~Max.	°CDB	-15 ~-46	-15~-46	-15~-46	-15~-46
	Heating	Ambient	Min.~Max.	°CWB	-15 ~-15.5	-15~-15.5	-15~-15.5	-15~-15.5
Refrigerant	Type/GWP			R-32/675	R-32/675	R-32/675	R-32/675	R-32/675
	Charge	kg/TCO2Eq		2.45/1.65	2.60/1.76			
Piping connections	Liquid/ Gas	OD	mm	9.52/15.9	9.52/15.9			
	Piping length	OU - IU	Max.	m	50	50		
		System	Equivalent	m	70	70		
			Chargeless	m	30	30		
	Level difference	IU - OU	Max.	m	30.0	30.0		
Additional refrigerant charge		kg/m		See installation manual	See installation manual			
Power supply	Phase/Frequency/Voltage	Hz/V	1~/50 /220-240	1~/50 /220-240		3~/50 /380-415		
Current - 50Hz	Maximum fuse amps (MFA)	A	20	25	32	16		

Contains fluorinated greenhouse gases

Floor standing unit

For commercial spaces with high ceilings

- Combining with Sky Air Alpha-series ensures best in class quality, highest efficiency and performance
- Decrease of temperature variation by automatic fan speed selection or freely selectable 3-step fan speed.
- Improved comfort as a result of better airflow distribution from the vertical out blow which allows manual adjustment of air outlet blades at the top of the unit.
- Selectable horizontal out blow to better suit the layout of the room (via wired remote controller BRC1E*/BRC1H*)

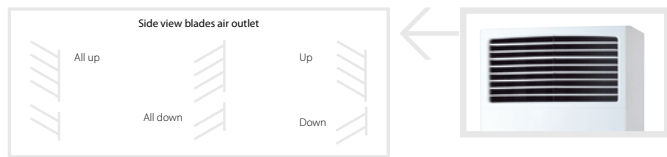

FVA-A RZAG-NV1 RZAG-NY1

Efficiency data		FVA + RZAG		71A + 71NV1	100A + 100NV1	125A + 125NV1	140A + 140NV1	71A + 71NY1	100A + 100NY1	125A + 125NY1	140A + 140NY1	
Cooling capacity	Nom.	kW		6.80	9.50	12.1	13.4	6.80	9.50	12.1	13.4	
Heating capacity	Nom.	kW		7.50	10.8	13.5	15.5	7.50	10.8	13.5	15.5	
Space cooling	Energy efficiency class			A++		-		A++		-		
	Capacity	Pdesign	kW	6.80	9.50	12.1	13.4	6.80	9.50	12.1	13.4	
	SEER			6.34	6.40	6.41	6.12	6.34	6.40	6.41	6.12	
	ηs,c		%	-	-	253	242	-	-	253	242	
	Annual energy consumption		kWh/a	376	520	1,133	1,314	376	520	1,133	1,314	
Space heating (Average climate)	Energy efficiency class			A+		-		A+		-		
	Capacity	Pdesign	kW	4.70	7.80	9.52		4.70	7.80	9.52		
	SCOP/A			4.05	4.20	4.15	3.94	4.05	4.20	4.15	3.94	
	ηs,h		%	-	-	163	155	-	-	163	155	
	Annual energy consumption		kWh/a	1,625	2,600	3,209	3,383	1,625	2,600	3,209	3,383	
Indoor unit		FVA		71A	100A	125A	140A	71A	100A	125A	140A	
Dimensions	Unit	HeightxWidthxD	Depth	mm		1,850x600x270		1,850x600x350		1,850x600x350		
Weight	Unit	kg		42	50			42	50			
Air filter	Type	Resin net										
Fan	Air flow rate	Cooling	Low/Medium/High	m³/min	14/16/18	22/25/28	24/26/28	26/28/30	14/16/18	22/25/28	24/26/28	26/28/30
		Heating	Low/Medium/High	m³/min	14/16/18	22/25/28	24/26/28	26/28/30	14/16/18	22/25/28	24/26/28	26/28/30
Sound power level	Cooling	dBA		55	62	63	65	55	62	63	65	
Sound pressure level	Cooling	Low/High	dBA		38/43	44/50	46/51	48/53	38/43	44/50	46/51	48/53
	Heating	Nom./High	dBA		41/43	47/50	48/51	51/53	41/43	47/50	48/51	51/53
Control systems	Wired remote control		BRC1H52W/S/K / BRC1E53A / BRC1E53B / BRC1E53C / BRC1D52									
Power supply	Phase/Frequency/Voltage		Hz/V		1~/50/60/220-240/220							
Piping connections	Drain		I.D. 20/O.D. 26									
Outdoor unit		RZAG		71NV1	100NV1	125NV1	140NV1	71NY1	100NY1	125NY1	140NY1	
Dimensions	Unit	HeightxWidthxD	Depth	mm								870x1,100x460
Weight	Unit	kg		81	85	95		81	85	94		
Sound power level	Cooling	dBA		64	66	69	70	64	66	69	70	
	Heating	dBA		-	-	68	71	-	-	68	71	
Sound pressure level	Cooling	Nom.	dBA	46	47	49	50	46	47	49	50	
	Heating	Nom.	dBA	48	50	52		48	50	52		
Operation range	Cooling	Ambient	Min.~Max.	°CDB		-20 ~52						
	Heating	Ambient	Min.~Max.	°CWB		-20 ~18						
Refrigerant	Type/GWP	R-32/675										
	Charge	kg/TCO2Eq		3.20/2.16		3.70/2.50		3.20/2.16		3.70/2.50		
Piping connections	Liquid/ Gas	OD		mm								9.52/15.9
	Piping length	OU - IU	Max.	m		85		55		85		
		System Equivalent Chargeless	m		75		100		75		100	
	Level difference	IU - OU	Max.	m		40						
	Additional refrigerant charge	kg/m		30								
Power supply	Phase/Frequency/Voltage		Hz/V		1~/50 /220-240				3~/50 /380-415			
Current - 50Hz	Maximum fuse amps (MFA)		A		20		32		16			

Contains fluorinated greenhouse gases

Floor standing unit

For commercial spaces with high ceilings

- Combination with Sky Air Advance-series ensures good value for money for all types of commercial applications
- Decrease of temperature variation by automatic fan speed selection or freely selectable 3-step fan speed.
- Improved comfort as a result of better airflow distribution from the vertical out blow which allows manual adjustment of air outlet blades at the top of the unit.
- Selectable horizontal out blow to better suit the layout of the room (via wired remote controller BRC1E*/BRC1H*)

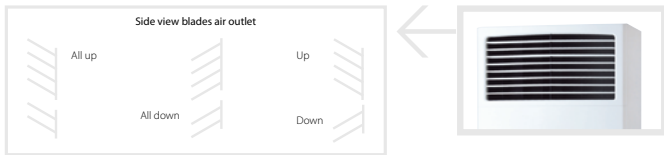

FVA-A RZASG-MV1 RZASG-MY1 RZASG-MV RZASG-MY

Efficiency data		FVA + RZASG	71A + 71MV1	100A + 100MV(1)	125A + 125MV(1)	140A + 140MV(1)	100A + 100MY(1)	125A + 125MY(1)	140A + 140MY(1)
Cooling capacity	Min./Nom./Max.	kW	6.80	9.50	12.1	13.4	9.50	12.1	13.4
Heating capacity	Min./Nom./Max.	kW	7.50	10.8	13.5	15.5	10.8	13.5	15.5
Space cooling	Energy efficiency class		A+	A+	-	-	A+	-	-
	Capacity Pdesign	kW	6.80	9.50	12.1	13.4	9.50	12.1	13.4
	SEER		5.83	5.72	5.52	5.63	5.72	5.52	5.63
	ηs,c	%	-	-	218	222	-	218	222
Space heating (Average climate)	Annual energy consumption	kWh/a	408	581	1,314	1,428	581	1,314	1,428
	Energy efficiency class		A+	A	-	-	A	-	-
	Capacity Pdesign	kW	4.50	6.00	6.00	7.80	6.00	6.00	7.80
	SCOP/A		4.04	3.83	3.64	3.81	3.83	3.64	3.81
ηs,h	%	-	-	143	149	-	143	149	
Annual energy consumption	kWh/a	1,559	2,193	2,308	2,866	2,193	2,308	2,866	
Indoor unit		FVA	71A	100A	125A	140A	100A	125A	140A
Dimensions	Unit HeightxWidthxDPTH	mm	1,850x600x270	1,850x600x350					
Weight	Unit	kg	42	50					
Air filter	Type		Resinnet						
Fan	Air flow rate	Cooling Low/Medium/High m³/min	14/16/18	22/25/28	24/26/28	26/28/30	22/25/28	24/26/28	26/28/30
	Heating Low/Medium/High m³/min	14/16/18	22/25/28	24/26/28	26/28/30	22/25/28	24/26/28	26/28/30	
Sound power level	Cooling	dBA	55	62	63	65	62	63	65
Sound pressure level	Cooling Low/Medium/High	dBA	38/41/43	44/47/50	46/48/51	48/51/53	44/47/50	46/48/51	48/51/53
	Heating Medium/Nom./High	dBA	38/41/43	44/47/50	46/48/51	48/51/53	44/47/50	46/48/51	48/51/53
Control systems	Wired remote control		BRC1H52W/S/K / BRC1E53A / BRC1E53B / BRC1E53C / BRC1D52						
Power supply	Phase - Frequency - Voltage	Hz - V	1~ - 50/60 - 220-240/220						
Outdoor unit		RZASG	71MV1	100MV(1)	125MV(1)	140MV(1)	100MY(1)	125MY(1)	140MY(1)
Dimensions	Unit HeightxWidthxDPTH	mm	770x900x320	990x940x320					
Weight	Unit	kg	60	70 (MY1)/72 (MY)		78 (MV1)/79 (MV)	70 (MY1)/72 (MY)		78 (MV1)/79 (MV)
Sound power level	Cooling	dBA	65	70	71	73	70	71	73
	Heating	dBA	-	-	71	73	-	71	73
Sound pressure level	Cooling Nom.	dBA	46	53		54	53		54
	Heating Nom.	dBA	47	57					
Operation range	Cooling Ambient Min.~Max.	°CDB	-15~-46						
	Heating Ambient Min.~Max.	°CWB	-15~-15.5						
Refrigerant	Type/GWP		R-32/675						
	Charge	kg/TCO2Eq	2.45/1.65	2.60/1.76		2.90/1.96	2.60/1.76		2.90/1.96
Piping connections	Liquid/Gas OD	mm	9.52/15.9						
	Piping length	OU - IU Max.	50						
	System Equivalent Chargeless	m	70						
	Additional refrigerant charge	kg/m	30						
	Level difference IU - OU Max.	m	See installation manual						
Power supply	Phase/Frequency/Voltage	Hz/V	1~/50 /220-240				3~/50 /380-415		
Current - 50Hz	Maximum fuse amps (MFA)	A	20	25	32		16		

Contains fluorinated greenhouse gases

Floor standing unit

For commercial spaces with high ceilings

- Ideal solution for small businesses and shops
- Decrease of temperature variation by automatic fan speed selection or freely selectable 3-step fan speed.
- Improved comfort as a result of better airflow distribution from the vertical out blow which allows manual adjustment of air outlet blades at the top of the unit.
- Selectable horizontal out blow to better suit the layout of the room (via wired remote controller BRC1E*/BRC1H*)

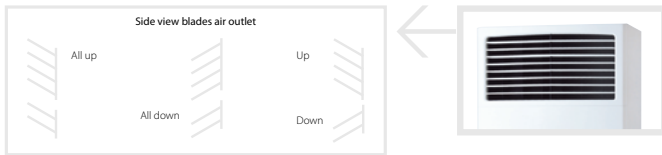

FVA-A AZAS-MV AZAS-MY

Efficiency data		FVA + AZAS	100A + 100MV	125A + 125MV	140A + 140MV	100A + 100NY	125A + 125NY	140A + 140NY		
Cooling capacity	Nom.	kW	9.50	12.1	13.4	9.50	12.1	13.4		
Heating capacity	Nom.	kW	10.8	13.5	15.5	10.8	13.5	15.5		
Space cooling	Energy efficiency class		A	-	-	A	-	-		
	Capacity	Pdesign	kW	9.50	12.1	13.4	9.50	12.1	13.4	
	SEER		5.5	5.3	5.4	5.5	5.3	5.4		
	ηs,c		%	-	209	213	-	209	213	
	Annual energy consumption	kWh/a	605	1,370	1,489	605	1,370	1,489		
Space heating (Average climate)	Energy efficiency class		A	-	-	A	-	-		
	Capacity	Pdesign	kW	6.00	7.80	6.00	7.80			
	SCOP/A		3.79	3.56	3.81	3.79	3.56	3.81		
	ηs,h		%	-	139	149	-	139	149	
	Annual energy consumption	kWh/a	2,217	2,360	2,866	2,217	2,360	2,866		
Indoor unit		FVA	100A	125A	140A	100A	125A	140A		
Dimensions	Unit	HeightxWidthxDpeth	mm			1,850x600x350				
Weight	Unit	kg		50			50			
Air filter	Type	Resin net								
Fan	Air flow rate	Cooling	Low/Medium/High	m³/min	22/25/28	24/26/28	26/28/30	22/25/28	24/26/28	26/28/30
		Heating	Low/Medium/High	m³/min	22/25/28	24/26/28	26/28/30	22/25/28	24/26/28	26/28/30
Sound power level	Cooling		dBA	62	63	65	62	63	65	
Sound pressure level	Cooling	Low/High	dBA	44/50	46/51	48/53	44/50	46/51	48/53	
	Heating	Nom./High	dBA	47/50	48/51	51/53	47/50	48/51	51/53	
Control systems	Wired remote control	BRC1H52W/S/K / BRC1E53A / BRC1E53B / BRC1E53C / BRC1D52								
Power supply	Phase/Frequency/Voltage	Hz/V	1~/50/60/220-240/220							
Piping connections	Drain	I.D. 20/O.D. 26								
Outdoor Unit		AZAS	100MV	125MV	140MV	100MY	125MY	140MY		
Dimensions	Unit	HeightxWidthxDpeth	mm					990x940x320		
Weight	Unit	kg		72			72			
Sound power level	Cooling		dBA	70	71	72	70	71	72	
	Heating		dBA	70	71	72	70	71	72	
Sound pressure level	Cooling	Nom.	dBA	53	54	55	53	54	55	
	Heating	Nom.	dBA	57	58	59	57	58	59	
Operation range	Cooling	Ambient	Min.~Max.	°CDB					-10~46	
	Heating	Ambient	Min.~Max.	°CWB					-15~15.5	
Refrigerant	Type/GWP	R-32/675								
Piping connections	Charge	kg/TCO2Eq	2.60/1.76		2.90/1.96		2.60/1.76		2.90/1.96	
	Liquid/Gas	OD	mm					9.52/15.9		
Piping connections	Piping	OU - IU	Max.	m					30	
	length	System	Equivalent	m					50	
		Chargeless		m					30	
Piping connections	Additional refrigerant charge	kg/m	See installation manual							
	Level difference	IU - OU	Max.	m					30.0	
Power supply	Phase/Frequency/Voltage	Hz/V	1~/50/220-240			3~/50/380-415				
Current - 50Hz	Maximum fuse amps (MFA)	A	25	32		16				

Contains fluorinated greenhouse gases

Concealed floor standing unit

Designed to be concealed in walls

- Combination with Sky Air Alpha-series ensures best in class quality, highest efficiency and performance
- Discretely concealed in the wall: only the suction and discharge grilles are visible
- Requires very little installation space as the depth is only 200mm
- Its low height (620 mm) enables the unit to fit perfectly beneath a window
- High ESP allows flexible installation



		FNA + RZAG		35A9 + 35A		50A9 + 50A		60A9 + 60A		
Efficiency data	Cooling capacity	Min./Nom./Max.	kW	1.6/3.5/4.5		1.7/5.0/6.0		1.7/6.0/6.5		
	Heating capacity	Min./Nom./Max.	kW	1.40/4.00/5.00		1.70/5.00/6.00		1.70/7.00/7.50		
Space cooling	Energy efficiency class					A+				
	Capacity	Pdesign	kW	3.50		5.00		6.00		
	SEER					5.90		5.70		
	Annual energy consumption			kWh/a		208		297		
Space heating (Average climate)	Energy efficiency class					A				
	Capacity	Pdesign	kW	3.50		4.30		4.50		
	SCOP/A					3.90				
	Annual energy consumption			kWh/a		1,255		1,542		
		FNA		35A9		50A9		60A9		
Dimensions	Unit	HeightxWidthxDepth	mm	620/720x790x200		620/720x1,190x200				
Weight	Unit		kg	23.0		30.0				
Air filter	Type					Resin net				
Fan	Air flow rate	Cooling	Low/High	m ³ /min	7.3/8.7		13.5/16.0			
		Heating	Low/High	m ³ /min	7.3/8.7		13.5/16.0			
	External static pressure		Nom./High	Pa	30/48		40/49			
Sound power level	Cooling		dBA	53.0		56.0				
Sound pressure level	Cooling	Low/Medium/High	dBA	28.0/31.0/33.0		30.0/33.0/36.0				
	Heating	Low/Nom./High	dBA	28.0/31.0/33.0		30.0/33.0/36.0				
Control systems	Infrared remote control					BRC4C65				
	Wired remote control					BRC1H52W/S/K / BRC1E53A / BRC1E53B / BRC1E53C / BRC1D52				
Power supply	Phase/Frequency/Voltage		Hz/V			1~/50/60/220-240/220				
		RZAG		35A		50A		60A		
Dimensions	Unit	HeightxWidthxDepth	mm			734x870x373				
Weight	Unit		kg			52				
Sound power level	Cooling		dBA	62.0		63.0		64.0		
	Heating		dBA	62.0		63.0		64.0		
Sound pressure level	Cooling	Nom.	dBA	48.0		49.0		50.0		
	Heating	Nom.	dBA	48.0		49.0		50.0		
Operation range	Cooling	Ambient	Min.~Max.	°CDB		-20~-52				
	Heating	Ambient	Min.~Max.	°CWB		-20~-24				
Refrigerant	Type/GWP					R-32/675.0				
	Charge			kg/TCO2Eq		1.55/1.05				
Piping connections	Liquid/Gas OD		mm	6.35/9.52		6.35/12.7				
	Piping length	OU - IU	Max.	m		50				
		System	Chargeless	m		30				
	Additional refrigerant charge			kg/m		0.02 (for piping length exceeding 30m)				
Power supply	Level difference IU - OU		Max.	m		30.0				
	Phase/Frequency/Voltage		Hz/V			1~/50/220-240				

Contains fluorinated greenhouse gases

Concealed floor standing unit

Designed to be concealed in walls

- Combination with split outdoor units is ideal for small retail, offices and residential applications
- Discretely concealed in the wall: only the suction and discharge grilles are visible
- Requires very little installation space as the depth is only 200mm
- Its low height (620 mm) enables the unit to fit perfectly beneath a window
- High ESP allows flexible installation



		FNA-A9	RXM-R	RXM-R9	RXM-A						
Efficiency data		FNA + RXM			25A9 + 25R9	35A9 + 35R9	50A9 + 50A	60A9 + 60R			
Cooling capacity	Nom.	kW			2.60	3.40	5.00	6.00			
Heating capacity	Nom.	kW			3.20	4.00	5.80	7.00			
Power input	Cooling	Nom. kW			0.68	1.10	1.48	2.22			
	Heating	Nom. kW			0.80	1.15	1.74	2.25			
Space cooling	Energy efficiency class				A+		A				
	Capacity	Pdesign kW			2.60	3.40	5.00	6.00			
	SEER				5.68	5.70	5.77	5.56			
	Annual energy consumption	kWh/a			160	209	303	378			
Space heating (Average climate)	Energy efficiency class				A+						
	Capacity	Pdesign kW			2.80	2.90	4.00	4.60			
	SCOP/A				4.24	4.05	4.09	4.16			
	Annual energy consumption	kWh/a			924	1,002	1,368	1,547			
Nominal efficiency	EER				3.80	3.09	3.38	2.70			
	COP				4.00	3.48	3.34	3.11			
	Annual energy consumption				kWh	342	550	740	1,111		
	Energy labeling Directive Cooling/Heating					A/A	B/B	A/C	D/D		
Indoor unit		FNA			25A9	35A9	50A9	60A9			
Dimensions	Unit	HeightxWidthxDepth mm			620/720x790x200		620/720x1,190x200				
Weight	Unit	kg			23.0		30.0				
Air filter	Type				Resinnet						
Fan	Air flow rate	Cooling	Low/High		m ³ /min		7.3/8.7		13.5/16.0		
		Heating	Low/High		m ³ /min		7.3/8.7		13.5/16.0		
	External static pressure	Nom./High		Pa		30/48		40/49			
Sound power level	Cooling	dBA			53.0		56.0				
Sound pressure level	Cooling	Low/Medium/High		dBA		28.0/31.0/33.0		30.0/33.0/36.0			
	Heating	Low/Nom./High		dBA		28.0/31.0/33.0		30.0/33.0/36.0			
Control systems	Infrared remote control				BRC4C65						
	Wired remote control				BRC1H52W/S/K / BRC1E53A / BRC1E53B / BRC1E53C / BRC1D52						
Power supply	Phase/Frequency/Voltage			Hz/V		1~/50/60/220-240/220					
Outdoor unit		RXM			25R9	35R9	50A	60R			
Dimensions	Unit	HeightxWidthxDepth mm			552x840x350		734x954x401				
Weight	Unit	kg			32		49.0				
Sound pressure level	Cooling	Nom.		dBA		46.0	49.0	48.0			
	Heating	Nom.		dBA		47.0	49.0				
Operation range	Cooling	Ambient	Min.~Max.		°CDB		-10~46				
	Heating	Ambient	Min.~Max.		°CWB		-15~18				
Refrigerant	Type				R-32						
	GWP				675		675.0				
	Charge				kg/TCO2Eq		0.76/0.52		1.15/0.780		
Piping connections	Liquid	OD		mm		6.35					
	Gas	OD		mm		9.52		12.7			
	Piping length	OU - IU	Max.		m		20		30		
		System	Chargeless		m		10				
	Additional refrigerant charge				kg/m		0.02 (for piping length exceeding 10m)				
Level difference IU - OU	Max.		m		15		20.0				
Power supply	Phase/Frequency/Voltage			Hz/V		1~/50 / 220-240					
Current - 50Hz	Maximum fuse amps (MFA)			A		13		16			

Contains fluorinated greenhouse gases



Biddle air curtains

Biddle air curtains provide highly efficient solutions for retailers and consultants to combat the issue of climate separation across their outlet or office doorway.

Benefits of Biddle air curtains

- Connectable to ERQ and VRV units
- Unified range for R-32 and R-410A refrigerant
- payback period of less than 1.5 years compared to installing an electric air curtain

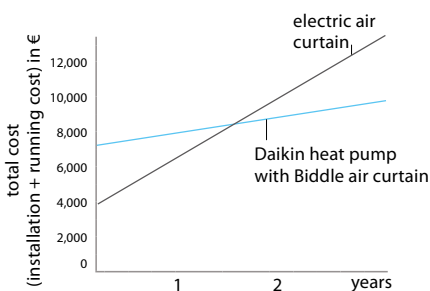

3 different models to choose from:



Free-hanging model (F):
easy wall mounted installation



Cassette model (C):
mounted into a false ceiling leaving only the decoration panel visible



Recessed model (R):
neatly concealed in the ceiling

Select your Biddle air curtain range

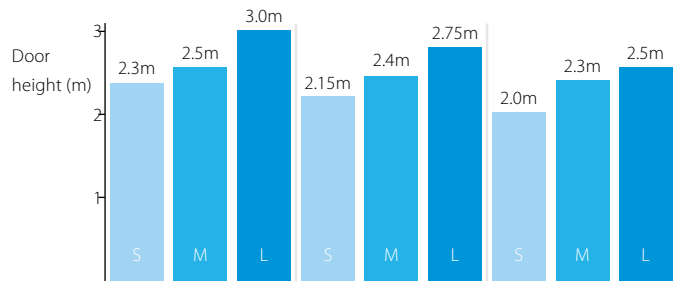

Installation condition

Favourable

ex: covered shopping mall or revolving door entrance

Normal

ex: little direct wind, no opposite open doors, building with ground floor only

Unfavourable

ex: location at a corner or square, multiple floors and/or open stairwell

Biddle air curtain nomenclature

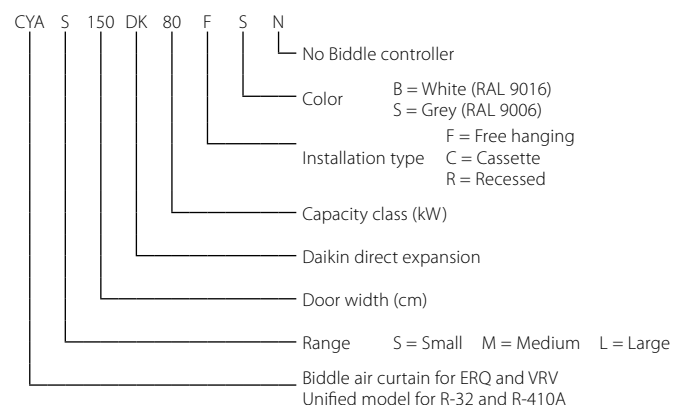

Biddle air curtain

- Connectable to ERQ and VRV DX outdoor units
- Unified model for R-32 and R-410A refrigerant
- Free-hanging model (F): easy wall mounted installation
- Cassette model (C): mounted into a false ceiling leaving only the decoration panel visible
- Recessed model (R): neatly concealed in the ceiling
- A payback period of less than 1.5 years compared to installing an electric air curtain
- Provides virtually free air curtain heating via recovered heat from indoor units in cooling mode (in case of VRV heat recovery)
- Easy and quick to install at reduced costs since no additional water systems, boilers and gas connections are required



CYA

				Small				Medium			
				CYAS100DK80*	CYAS150DK80*	CYAS200DK100*	CYAS250DK140*	CYAM100DK80*	CYAM150DK80*	CYAM200DK100*	CYAM250DK140*
Heating capacity	Speed 3		kW	6.94	8.6	10.9	15.2	8.65	10.5	12.5	18.6
Power input	Fan only	Nom.	kW	0.14	0.21	0.28	0.36	0.27	0.40	0.53	0.67
	Heating	Nom.	kW	0.14	0.21	0.28	0.36	0.27	0.40	0.53	0.67
Delta T	Speed 3		K	17.7	14.6	13.9	15.5	16	12.9	12.7	13.8
Casing	Colour	B: RAL9016 / S: RAL9006				B: RAL9016 / S: RAL9006					
Dimensions	Unit	Height F/C/R	mm	270/270/270				270/270/270			
		Width F/C/R	mm	1,000/1,000/1,048	1,500/1,500/1,548	2,000/2,000/2,048	2,500/2,500/2,548	1,000/1,000/1,048	1,500/1,500/1,548	2,000/2,000/2,048	2,500/2,500/2,548
		Depth F/C/R	mm	590/821/561				590/821/561			
Required ceiling void >		mm	420				420				
Door height	Max.		m	2.3				2.5			
Door width	Max.		m	1	1.5	2	2.5	1	1.5	2	2.5
Weight	Unit		kg	56/59/61	66/83/88	83/102/108	107/129/137	57/68/66	73/88/93	94/111/117	108/136/144
Fan		Speed 3	m ³ /h	1,164	1,746	2,328	2,910	1,605	2,408	2,910	4,013
Sound pressure level	Heating	Speed 3	dBA	47	49	50	51	50	51	53	54
Refrigerant	GWP	675/2,087.5				675/2,087.5					
	Type	R32/R410A				R32/R410A					
Piping connections	Liquid	OD	mm	6.35		9.52		6.35		9.52	
	Gas	OD	mm	12.7		15.9		12.7		15.9	
Air filter	Type	Vacuum cleanable filter G1									
Power supply	Frequency		Hz	50Hz				50Hz			
	Voltage		V	230V				230V			
	Maximum fuse amps (MFA)		A	16				16			
				Large							
				CYAL100DK125*	CYAL150DK200*	CYAL200DK250*	CYAL250DK250*				
Heating capacity	Speed 3		kW	14.4	21.5	27.6	29.7				
Power input	Fan only	Nom.	kW	0.48	0.72	0.96	1.20				
	Heating	Nom.	kW	0.48	0.72	0.96	1.20				
Delta T	Speed 3		K	13.8	13.7	13.2	11.4				
Casing	Colour	B: RAL9016 / S: RAL9006									
Dimensions	Unit	Height F/C/R	mm	370/370/370							
		Width F/C/R	mm	1,000/1,000/1,048	1,500/1,500/1,548	2,000/2,000/2,048	2,500/2,500/2,548				
		Depth F/C/R	mm	774/1,105/745							
Required ceiling void >		mm	520								
Door height	Max.		m	3							
Door width	Max.		m	1	1.5	2	2.5				
Weight	Unit		kg	76/81/83	100/118/141	126/151/155	157/190/196				
Fan		Speed 3	m ³ /h	3,100	4,650	6,200	7,750				
Sound pressure level	Heating	Speed 3	dBA	53	54	56	57				
Refrigerant	GWP	675/2,087.5									
	Type	R32/R410A									
Piping connections	Liquid	OD	mm	15.9		19.1		9,522		19.1	
	Gas	OD	mm	15.9		19.1		9,522		19.1	
Air filter	Type	Vacuum cleanable filter G1									
Power supply	Frequency		Hz	50Hz							
	Voltage		V	230V							
Current	Maximum fuse amps (MFA)		A	16							

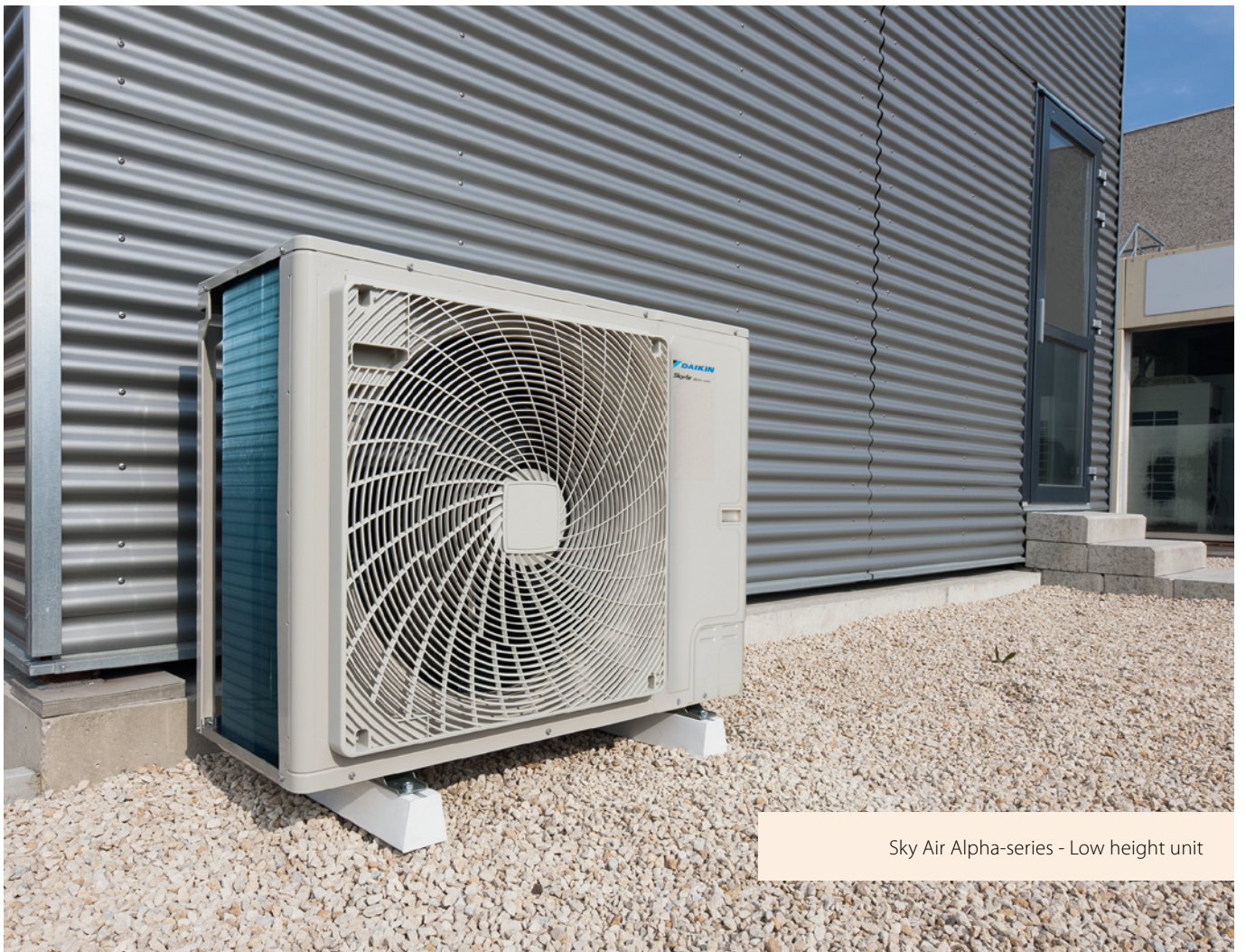

Sky Air Alpha-series - Low height unit



Low sound enclosure for Sky Air
Alpha-series (RZAG-N) and advance-series (RZA-D)

Outdoor units

A range of industry leading technology outdoor units

Products overview outdoor units	62
Benefits overview outdoor units	63
SkyAir A-series	63
Low sound enclosure	64
Replacement technology	70
Variable Refrigerant Temperature	72
Infrastructure cooling	73

R-32 BLUEEVOLUTION range 82

▪ RZAG-A SkyAir Alpha-series	82
▪ RZAG-NV1/NY1 SkyAir Alpha-series	82
▪ RZASG-MV(1)/MY(1) SkyAir Advance-series	83
▪ RZA-D SkyAir Advance-series	84
▪ ARXM-R/ AZAS-MV/MY SkyAir Active-series	85

Multi model and VRV range

- See Split or VRV chapter

Pair solution

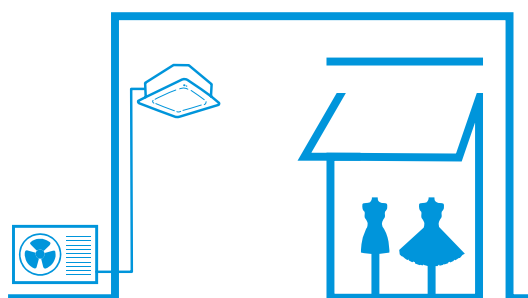

Twin, triple, double twin solution

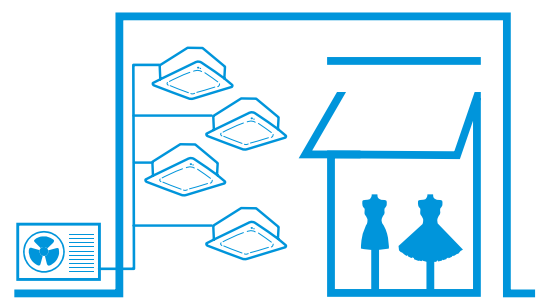



Low height. High value.

Products overview outdoor units

Pair, twin, triple & double twin application

BLUEEVOLUTION

R-32

SkyAir A-series

System	Type	Model	Product name	35	50	60	71	100	125	140	200	250
				3.5 kW	5.0 kW	6.0 kW	6.8 kW	9.5 kW	12.1 kW	13.4 kW	21.5 kW	23.6 kW
Air cooled	Heat pump	SkyAir Alpha-series <ul style="list-style-type: none"> Industry leading technology for commercial applications Dedicated solution for infrastructure cooling Variable Refrigerant Temperature (RZAG71-100-125-140 series) Maximum piping length up to 85m (50m for RZAG35-50-60) Replacement technology Extended operation range down to -20°C in both heating and cooling Pair, twin, triple and double twin application (RZAG71-100-125-140 series) 	R-32 A++ (A+++ - D)	RZAG-A								
		SkyAir Advance-series <ul style="list-style-type: none"> Technology and comfort combined for commercial applications Very compact and easy to install outdoor units Maximum piping length up to 50m (RZA-D up to 100m) Replacement technology Operation range down to -15°C both cooling and in heating (RZA-D down to -20°C) Pair, twin, triple and double twin application 	R-32 A+ (A+++ - D)	RZASG-MV(1)/MY(1)								
			RZA-D									
		SkyAir Active-series <ul style="list-style-type: none"> Ideal solution for busy environments and small shops Very compact and easy to install outdoor units Maximum piping length up to 30m Replacement technology Easy-to-mount outdoor units: roof, terrace or wall Exclusively offered for pair applications 	R-32 A (A+++ - D)	ARXM-R								
			AZAS-MV/MY									

Benefits overview outdoor units

		<i>SkyAir</i> Alpha-series		<i>SkyAir</i> Advance-series		<i>SkyAir</i> Active-series	<i>SkyAir</i> Active-series
		RZAG-A	RZAG-NV1/NY1	RZASG-MV(1)/MY(1)	RZA-D	AZAS-MV/MY	ARXM-R(9)
We care icons	Seasonal efficiency - Smart use of energy	Seasonal efficiency gives a more realistic indication on how efficient air conditioners operate over an entire heating or cooling season.	A++ (A+++ - D)	A++ (A+++ - D)	A+ (A+++ - D)	A (A+++ - D)	A (A+++ - D)
	Inverter technology	Inverter compressors continuously adjust compressor speed to actual demand. Fewer power-consuming starts and stops result in decreased energy consumption (up to 30%) and more stable temperatures.	•	•	•	•	•
	Replacement technology	Quick and quality system replacement in the most cost effective way	•	•	•	•	•
Comfort	Night quiet	Lowers the operation sound of the outdoor unit automatically.	•	•	•	•	•
	Auto cooling-heating changeover	Automatically selects cooling or heating mode to achieve the set temperature.	•	•	•	•	•
Other functions	Variable refrigeration temperature	The intelligent systems ensures highest energy savings with additional comfort to better suit application requirements.		•			
	Twin/triple/double twin application	2, 3 or 4 indoor units can be connected to only 1 outdoor unit. All indoor units operate within the same mode (cooling or heating) from one remote control.		•	•		
	Swing compressor	Outdoor units are fitted with a swing compressor, renowned for its low noise and high reliability	•	•	•	•	•
	Guaranteed operation down to -20°C	Daikin is suitable for all climates, even withstanding severe winter conditions with an operation range down to -20°C.	•	•		•	
	Infrastructure cooling	For high sensible, infrastructure cooling applications, dedicated infrastructure cooling settings and allowing asymmetric combinations enhance the system's reliability.	•	•			
	Low sound enclosure	Dedicated Daikin developed and tested low sound enclosure, reducing sound power by up to -10 dB(A)		○		○	

Technical benefit overview



	<i>SkyAir</i> Alpha-series		<i>SkyAir</i> Advance-series		<i>SkyAir</i> Active-series	<i>SkyAir</i> Active-series
	RZAG-A	RZAG-NV1/NY1	RZASG-MV(1)/MY(1)	RZA-D	AZAS-MV/MY	ARXM-R(9)
Compact single fan casing on the entire range	•	•	•	•	•	•
Maximum piping length	50 m	85 m	50 m	100 m	30 m	30 m
Pivoting front plate		•		•		
7 segment display		•	•	•	•	•
Increased factory charge	•	•				
Integrated leak check		•				
Refrigerant bottom plate pass		•				
Specially developed R-32 swing compressor	•	•	•	•	•	•
Refrigerant cooled PCB		•	•	•	•	•
Intelligent Tablet controller - Onecta app	○	○	○	○	○	○

• standard, ○ optional



- 10 dB(A)!

Low sound enclosure

EKLN140A

Meet strict sound requirements, while increasing flexibility to apply Sky Air and VRV systems thanks to sound power reduction of up to 10 dB(A)

- ✓ Specially designed for Sky Air and VRV heat pumps
- ✓ Factory tested and guaranteed data for capacity, efficiency and sound (according to ISO 3744)
- ✓ Minimal capacity reduction
- ✓ No additional calculations needed thanks to factory tested data, reducing design workload

Tried and tested: values that you can rely on

You want to finish your work faster? You want reliable results? You want your customers to get exactly what they ordered?

Our low sound enclosure eliminates possible problems and reduces your workload significantly:

- **No incompatibilities** – tested combinations with the outdoor unit that you want to encase
- **No surprises** – measured and guaranteed sound reduction according to ISO 3744
- **No calculations** – tested performance values for capacity and efficiency



Sound power level measurement in acoustic chamber



Sound enclosure				EKLN140A	
Casing	Colour			Anthracite (RAL 7016)	
	Material			Sheet metal	
Dimensions	Unit	Height	mm	1,100	
		Width	mm	1,400	
		Depth	mm	1,500	
	Packed unit	Height	mm	1,017	
		Width	mm	1,517	
		Depth	mm	917	
Weight	Unit		kg	152	
	Packed unit		kg	186	
Combines with	Sky Air Alpha-series		RZAG-NV1/NY1		
	Sky Air Advance-series		RZA-D		
	VRV 5 S-series		RXYS-AV1/AY1		

Benefits

- ✔ Dedicated Daikin option for:
 - Sky Air Alpha-series
 - Sky Air Advance-series
 - VRV 5 S-series
- ✔ Fully optimised and tested in Daikin factory
 - Guaranteed performance levels (sound, capacity, efficiency)
- ✔ Outdoor unit sound reduction of up to -10 dB(A) on sound power levels
 - Enabling to meet local sound requirements
 - Increased flexibility to apply outdoor units
 - Reduces sound on the entire sound spectrum
- ✔ Minimal capacity reduction
 - Separated air intake and discharge to prevent air flow short circuit
 - No additional calculations needed thanks to factory tested data
- ✔ Easy to integrate
 - Anthracite (RAL 7016), highly aesthetic finishing
 - Mechanically designed to perfectly suit the Sky Air Alpha/Advance and VRV 5 S-series casings
 - Self-supporting; can be installed on any flat surface
- ✔ Fast & easy installation & servicing
 - 100 % weather resistant
 - Easy opening to access most system components
- ✔ Durable
 - 3 years warranty on all components
 - Made of stainless steel with robust double layer powder coating, ensuring maximum corrosion resistance

Increased flexibility to apply heat pumps based on tested data

The reduction of the sound power levels (up to -10 dB(A)) across the entire sound spectrum increases your flexibility significantly. In the example below with the low sound enclosure, the heat pump can be installed as close as 5.5 m to the next premises, based on the 32 dB(A) threshold (check local regulations). Thanks to the precise Daikin sound and capacity data you can be confident about the solution you are offering.

Without Daikin sound enclosure **you need to maintain a 15 m distance** from your closest neighbour

With the Daikin sound enclosure **you can install as close as 5.5 m** from your closest neighbour

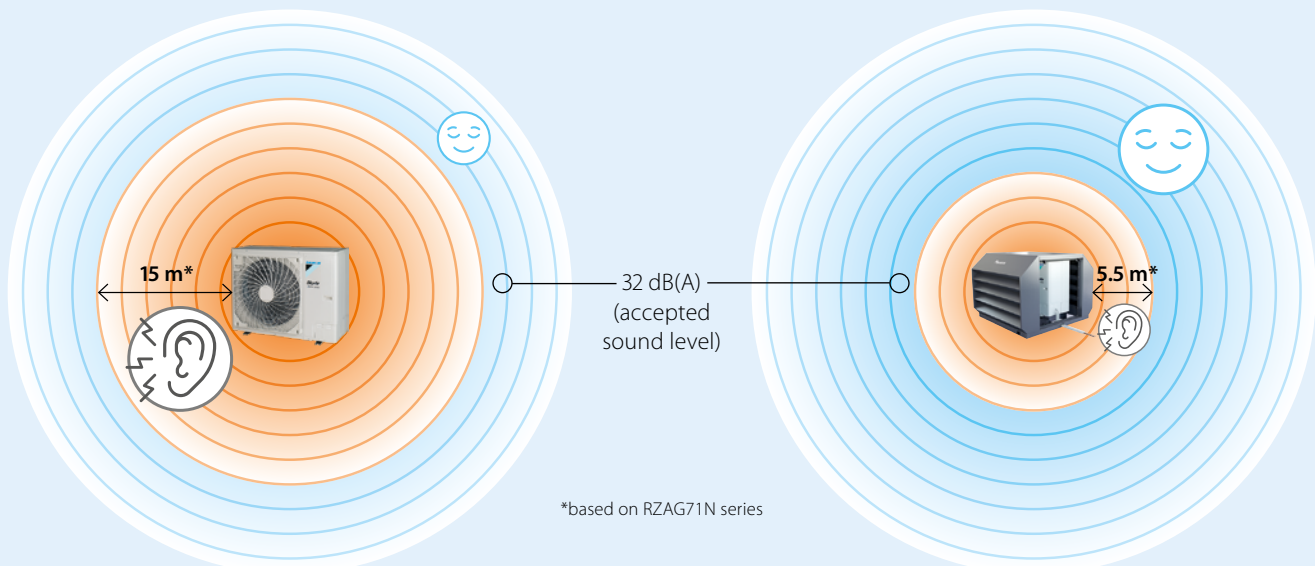

Tested to ease your work!

Double win with Daikin

Validated data

The sound enclosure is extensively tested with all suitable outdoor units. We offer measured data for:

- Sound power (heating/cooling) according to ISO 3744
- Sound pressure (heating/cooling) at 1 m distance
- Sound pressure for low noise operation
- Sound enclosure insertion loss
- All data delivered in octave band spectra and A-weighted sound level



EKLN-A



Sound power reduction values

Range	Outdoor unit name	Cooling sound power		Heating sound power	
		Sound reduction	Nominal sound with sound enclosure	Sound reduction	Nominal sound with sound enclosure
Sky Air Alpha-series	RZAG71NV1/NY1	-9 dB(A)	55	-7 dB(A)	57
	RZAG100NV1/NY1	-8 dB(A)	58	-8 dB(A)	60
	RZAG125NV1/NY1	-10 dB(A)	59	-10 dB(A)	59
	RZAG140NV1/NY1	-9 dB(A)	61	-9 dB(A)	62
Sky Air Advance-series	RZA200D	-7 dB(A)	66	-5 dB(A)	72
	RZA250D	-6 dB(A)	70	-5 dB(A)	75
VRV 5 S-series	RXYS44AV1/AY1	-7 dB(A)	60	-7 dB(A)	61
	RXYS45AV1/AY1	-8 dB(A)	60	-9 dB(A)	60
	RXYS46AV1/AY1	-8 dB(A)	61	-9 dB(A)	61

Efficiency and capacity impact

Range & outdoor unit name	Outdoor unit only		With sound enclosure		Outdoor unit only		With sound enclosure		Outdoor unit only		With sound enclosure		Correction factor maximum capacity	
	SEER/η s,c	SCOP/η s,h	SEER/η s,c	SCOP/η s,h	SEER/η s,c	SCOP/η s,h	SEER/η s,c	SCOP/η s,h	SEER/η s,c	SCOP/η s,h	SEER/η s,c	SCOP/η s,h	Cooling	Heating
Sky Air Alpha-series	+ FCAHG71/100/125/140A				+ FCAG71/100/125/140B				+ FBA71/100/125/140A					
RZAG71NV1/NY1	7.90/-	4.56/-	6.72/-	4.10/-	6.83/-	4.22/-	5.81/-	3.80/-	6.50/-	4.20/-	5.53/-	3.78/-	85 %	90 %
RZAG100NV1/NY1	7.70/-	4.75/-	6.62/-	4.44/-	7.14/-	4.53/-	6.07/-	4.14/-	6.47/-	4.36/-	5.50/-	4.01/-	86 %	
RZAG125NV1/NY1	8.02/318	4.53/178	6.96/275	4.26/167	7.14/283	4.34/171	6.26/247	4.15/163	6.56/259	4.37/172	5.92/234	4.12/162	90 %	
RZAG140NV1/NY1	7.93/314	4.44/175	6.84/271	4.21/165	6.80/269	4.34/171	5.83/230	4.17/164	6.42/254	4.34/171	5.62/222	4.14/162		
Sky Air Advance-series	+ FDA200/250A				+ 4 x FCAG50/60B				+ 4 x FBA50/60A					
RZA200D	6.26/247	3.59/141	5.90/233	3.17/124	7.16/283	4.10/161	6.52/258	3.56/140	6.51/257	4.20/165	5.90/233	3.65/143	84 %	80 %
RZA250D	5.38/212	3.55/139	4.91/193	3.14/123	6.95/275	4.10/161	6.18/244	3.56/139	6.69/264	4.33/170	5.95/235	3.78/148		
VRV 5 S-series	+ FXSA**													95 %
RXYS44AV1	8.2/324	5.1/200	7.2/284	4.9/193										
RXYS44AY1	7.9/312	4.9/193	6.9/273	4.7/186										
RXYS45AV1	7.7/306	4.7/186	6.7/264	4.5/178										
RXYS45AY1	7.4/295	4.5/179	6.4/254	4.4/172										
RXYS46AV1	7.6/301	4.7/184	6.5/257	4.5/176										
RXYS46AY1	7.3/290	4.5/177	6.3/248	4.3/170										

**4 HP: + 3 x FXSA25A + 1 x FXSA32A 5 HP: + 4 x FXSA32A 6 HP: + 2 x FXSA32A + 2 x FXSA40A

Sound power levels – cooling and heating, according to ISO 3744

- dB(A) = A-weighted sound power level (A scale according to IEC)
- Reference acoustic intensity: 0 dB = 10⁻¹² W

■ RZAG125N
■ RZAG125N + EKLN140A

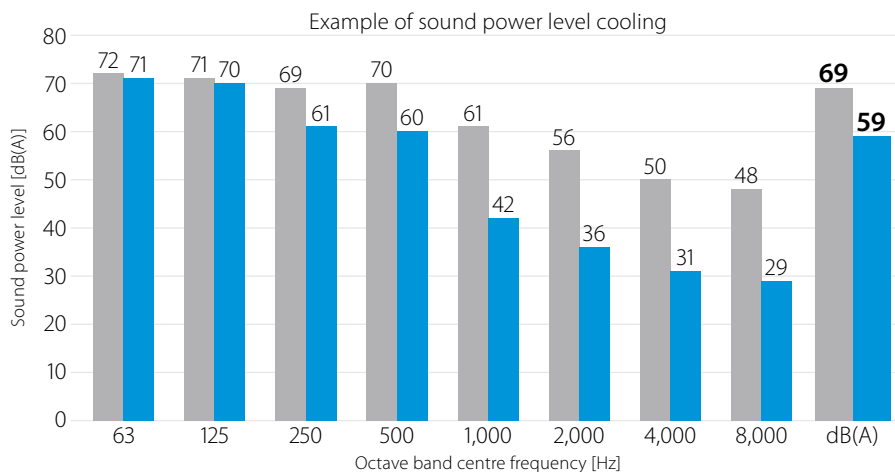

Sound pressure levels – cooling and heating

- Data is valid at free field condition
- Data is valid at nominal operation conditions
- dB(A) = A-weighted sound pressure level (A scale according to IEC)
- Reference acoustic pressure 0 dB = 20 µPa
- Microphone location at the discharge side; 1 m from the object; 1.5 m above the ground

■ RZAG125N
■ RZAG125N + EKLN140A

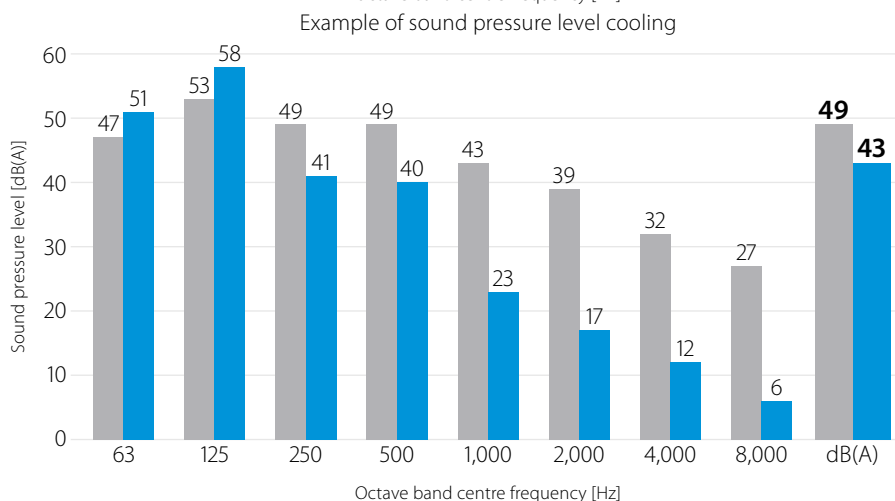

Sound pressure levels – low noise operation (level 3)

- Data is valid at free field condition
- Data is valid at nominal operation conditions
- dB(A) = A-weighted sound pressure level (A scale according to IEC)
- Reference acoustic pressure 0 dB = 20 µPa
- Microphone location at the discharge side; 1 m from the object; 1.5 m above the ground

■ RZAG125N
■ RZAG125N + EKLN140A

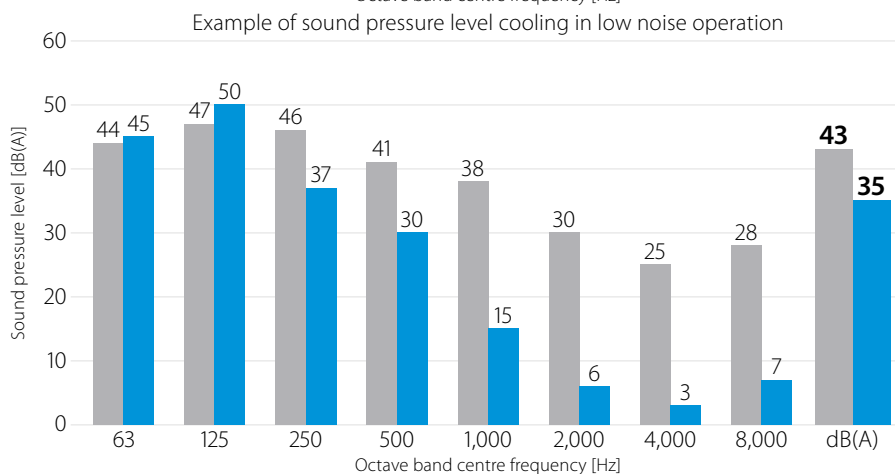

Insertion loss values

- Insertion loss measurement of standalone enclosure with calibrated sound source

■ Sound power level [dB(A)]
■ Reference sound source (RSS): B&K Type 4204 RSS

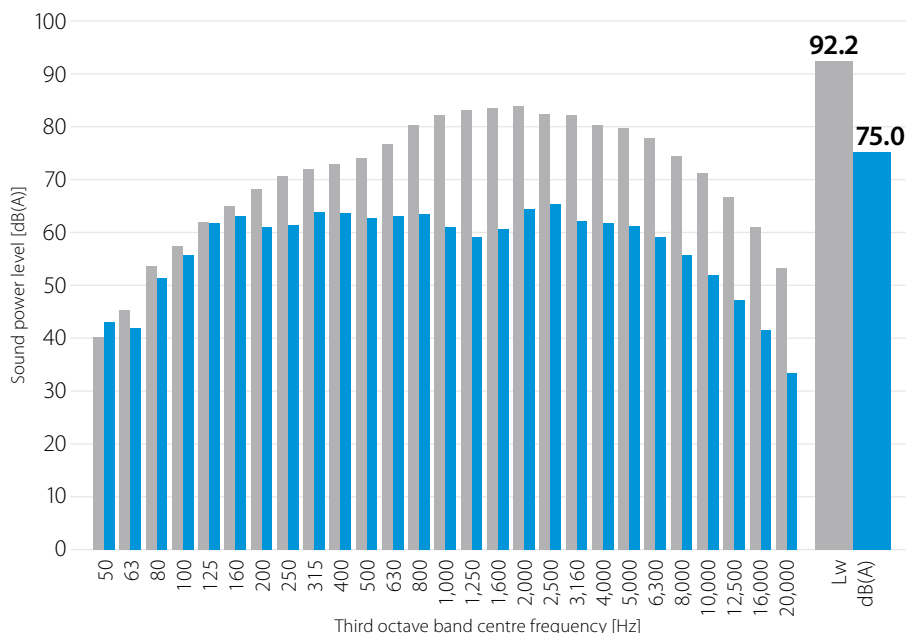
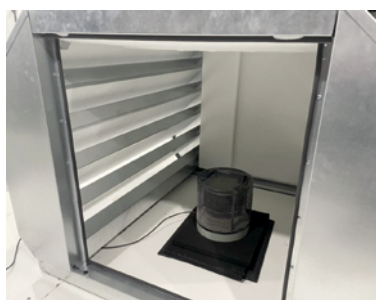

Low height.
High value.



Unique, low-height single fan range

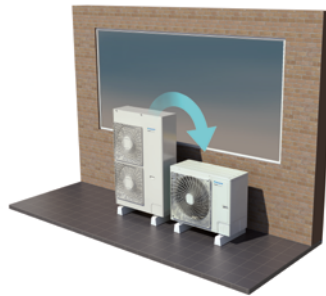

Compact unit, easy to transport

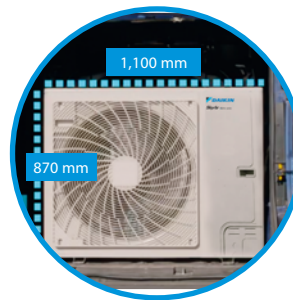

Market-leading serviceability and handling



Fast and easy access to all critical component

- Single screw access
- Wider access area



Newly positioned handle for easier carrying

✓ Very long piping length

- Up to 85m for RZAG-NV1/NY1
- Up to 100m for RZA-D

✓ Wide operation range down to -20°C

- Cooling operation from -20°C up to +52°C (+46°C for RZA-D)
- Heating operation down to -20°C

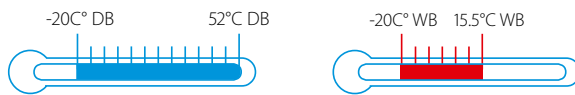

✓ Faster installation with up to 40m pre-charged pipe

- Up to 60% of applications can be installed without additional refrigerant charge
- 40m pre-charge for RZAG-NV1/NY1
- 30m pre-charge for RZA-D

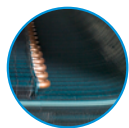

3-row heat exchanger

- Unique 3-row heat exchanger to allow compact casing up to 14kW



Bottom plate and heat exchanger refrigerant pass

- Drain holes are kept ice free
- Guaranteed operation down to -20°C

Swing compressor optimised for seasonal efficiency

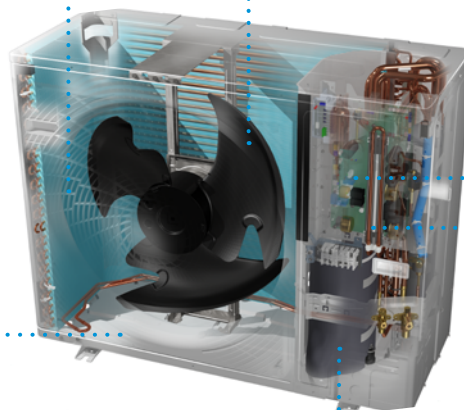

New and bigger fan design

- Ensures high air volume with low air velocity
- Reduces sound emissions

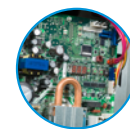

New 7-segment display to view errors and systems settings

Refrigerant cooled PCB



Replacement technology

The quick and quality way of upgrading R-22 and R-410A systems

Benefits to increase your profit
Optimise your business

Less installation time

Tackle more projects in less time thanks to faster installation. It is more profitable than replacing the full system with new piping.

Lower installation costs

Reducing installation costs enables you to offer customers the most cost-effective solution and improve your competitive edge.

Replace non-Daikin systems



It is a trouble-free replacement solution for Daikin systems and for systems made by other manufacturers.

Easy as one-two-three

A simple solution for replacement technology enables you to handle more projects for more customers in less time and offer them the best price! Everybody gains.

The benefits will convince your customer

- To prevent unexpected breakdown
- To lower running costs
- To protect the environment
- To improve comfort

Your copper pipes will last for multiple generations

Copper pipes used in air conditioning systems tested by Daikin will last over 60 years after installation.

How does it work?

The Daikin low-cost upgrade solution

! Replace indoor units

Contact your local dealer to check compatibility in case you need to keep the indoor units.

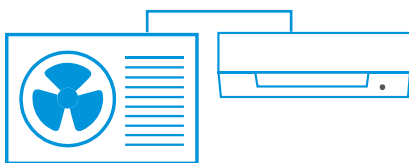

✓ Replace outdoor units

Unique technologies

- Cleaning free piping re-usage thanks to unique hepta filtering for maximum particle reduction

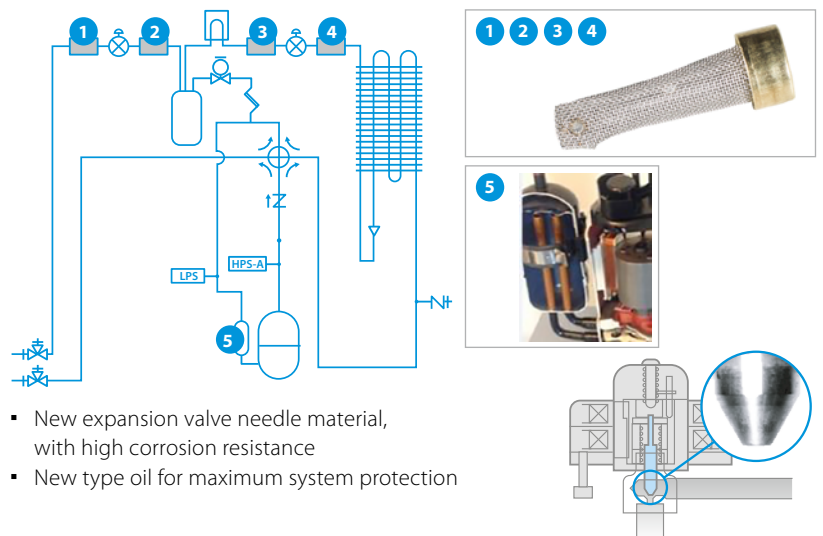

- New expansion valve needle material, with high corrosion resistance
- New type oil for maximum system protection

Learn more about Daikin replacement solutions at
www.daikin.eu/en_us/knowledge-center/replacement-technology.html

New simplified replacement procedure with Sky Air A-series outdoor units



How does it work?

1 Evaluate if the pipe work can be re-used

- Check if the piping installation is according to standards, that there no fractures or damages and that liquid and gas pipe have separate insulation
- Verify pipe thickness

Outside diameter (mm)	Material	Thickness (mm)
6.4	o	0.8
9.5	o	0.8
12.7	o	0.8
15.9	o	1.0
19.1	1/2H	1.0

o: annealed - 1/2H: half hard

- Verify piping diameter

Sky Air	Liquid	6.4			9.5				12.7				✓ Possible (Standard condition)	
		9.5	12.7	15.9	12.7	15.9	19.1	22.2	25.4	15.9	19.1	22.2		25.4
	Gas	✓	x	x	x	x	x	x	x	x	x	x	x	o Possible (With no impact on chargeless length and total length)
	3.5kW	✓	x	x	x	x	x	x	x	x	x	x	x	
	5.0kW	Δ	✓	o	Δ	Δ	x	x	x	x	x	x	x	Δ Possible (With impact on chargeless length and total length)
	6.0kW	Δ	✓	o	Δ	Δ	x	x	x	Δ	x	x	x	
	7.1kW	x	Δ	Δ	x	✓	x	x	x	Δ	x	x	x	
	10.0-14.0kW	x	x	Δ	x	✓	o	x	x	Δ	Δ	x	x	
	20.0-25.0kW	x	x	x	x	x	x	✓	o	x	x	Δ	Δ	x Impossible

- Verify the piping length

	Liquid pipe (mm)	35	50	60	71	100	125-140	200-250
Chargeless (equivalent)	6.4	30 (40) m	30 (40) m	30 (40) m		10 / (15) m		N/A
	9.5	-	15 (20) m	15 (20) m		40 / (50) m		N/A
	12.7	-	-	10 (15) m		15 / (20) m		N/A
Max. total length (equivalent)	6.4	50 (65) m	50 (65) m	50 (65) m		10 / (15) m		N/A
	9.5	-	25 (35) m	25 (35) m	55 / (75) m	85 / (100) m		100 m
	12.7	-	-	10 (15) m	25 / (35) m	35 / (45) m		50 m

- Check if any operation history affects the ability to re-use the pipes(systems with a pipe length up to 35m, can always re-use existing pipe work when using a new Sky Air A-series model)

System to be replaced	System condition	Piping length	R-32 Sky Air A-series
R-22 (mineral oil)	Unit is operating (pump down can be performed)	No restrictions	✓
	Pump down operation impossibility or compressor malfunction	Below 35 m	✓
		Above 35 m	o
R-410A (synthetic oil)	Unit is operating (pump down can be performed)	No restrictions	✓
	Pump down operation impossibility or compressor malfunction	Below 35 m	✓
		Above 35 m	o
R-32 (synthetic oil)	Unit is operating (pump down can be performed)	No restrictions	✓
	Pump down operation impossibility or compressor malfunction	Below 35 m	✓
		Above 35 m	o

✓ Cleaning-free piping re-use
o Cleaning of field piping or replacement of field piping is required

- The Flare connection MUST be redone by using the flare nut included with the new outdoor unit

2 Evaluate if the wiring can be re-used

- Check if the wiring meets current standard and the specification of the new unit and that there is no damage or scratches



Variable Refrigerant Temperature



The ultimate customer experience

- ✓ Increases air discharge temperature and eliminates cold drafts!
- ✓ Increased customer comfort and reduced energy consumption!
- The system automatically increases its evaporating temperature (T_e) when the gap between the actual indoor temperature (T_{in}) and the setpoint (T_{set}) is becoming smaller, increasing comfort and providing more stable operation

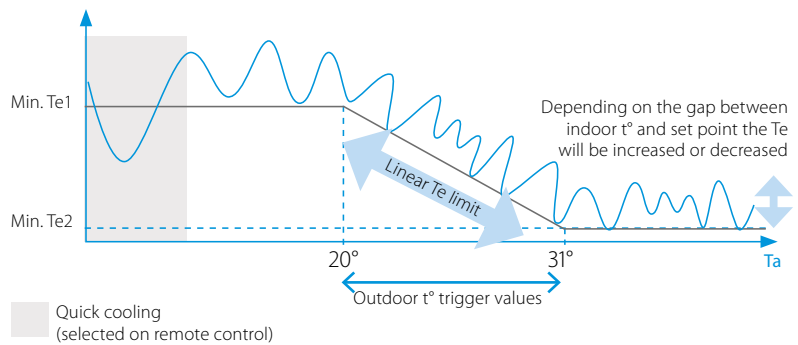

Case study: JBC, Vilvoorde

- ✓ Two pair systems are installed in the same zone allowing comparison
 - ✓ More energy efficient: up to 20% lower energy consumption
- Average energy consumption over 5 months of operation

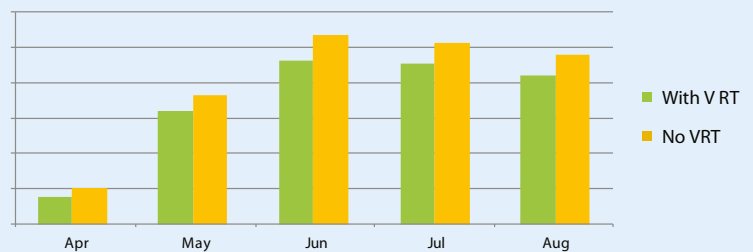

- ✓ Improved comfort: higher discharge temperatures
- More stable and continuous operation
- Average discharge temperature increased with 3~4°C





Infrastructure cooling

Daikin is the world leader when it comes to cooling. With over 90 years of innovation and engineering expertise in specialised cooling, Daikin offers a Sky Air solution that is **reliable**, **efficient** and **flexible** to meet the demanding needs of infrastructure cooling environments.



Reliable

Guaranteed system operation:

- Oversized indoor units boost cooling capacity and prevent freeze-ups on the indoor side
- Wide operating range envelope: operation range in cooling down to -20°C and up to +52°C

Efficient

Optimum return on investment:

- Lowers running costs by using highly efficient direct expansion cooling systems
- Lower running costs compared to other DX systems and water based chillers.
- Reduces mechanical cooling and energy consumption with the free cooling option for single phase systems

Flexible

- Scalable in capacity
- Improved infrastructure control and management
- Lower physical footprint since no floor space is occupied
- Wide range of indoor units to suit application preferences

UNIQUE

Dedicated system combinations

Benefits

- 1 Boost the heat transfer capacity of the indoor system
- 2 Ability to work with higher evaporation temperatures (Te) avoids downtime and enables continuous operation
- 3 Official energy labels for indoor and outdoor system combinations provide standardized and reliable performance data

UNIQUE

2-step solution for system selection

Benefits

- 1 Daikin makes the system selection procedure easy and reliable by providing detailed capacity tables based on extensive testing.
- 2 Choose the best product combination that meets end-user requirements

UNIQUE

Efficient cooling

Benefits

- 1 Free cooling: optimum energy efficiency using cold ambient air
- 2 Widest range of indoor systems with best in class energy efficiency
- 3 Wide indoor and outdoor operation range, reliable performance even in extreme conditions

UNIQUE

Flexible control

Benefits

- 1 Optimal backup supported by duty rotation control, automatic backup activation and remote alarms
- 2 Guaranteed continuous operation from extended compressor limits
- 3 Controller settings to adapt to specific infrastructure cooling environment conditions
- 4 Fewer start/stop cycles



Click or scan the code to access all technical information



Find out more in our infrastructure cooling brochure

Boosted capacity indoor systems

High reliability at lower running costs for infrastructure cooling

Split air conditioning systems for normal comfort cooling applications usually combine indoor systems with matching capacities, or multiple indoor systems with capacities lower than the outdoor system's capacity. This works because the indoor system's cooling capacity is sufficient to handle the higher humidity conditions and varying indoor temperature requirements that are common in a normal living environment.

Applying this design logic to infrastructure cooling environments can lead to risky situations that might compromise overall system reliability and frequent downtimes of 15 minutes.

Indoor systems for infrastructure cooling environments need enhanced capabilities for continuous heat transfer because they work harder to extract energy by cooling dry air. Daikin recommends and offers asymmetric combinations

(boosted capacity indoor combinations: e.g. 71 class outdoor + 100 class indoor).

You can now confidently combine indoor systems with higher capacities than the outdoor system. This will boost heat transfer inside the technology or server room environments.

Infrastructure cooling application system solutions

Traditional solution

Symmetric indoor-outdoor system combination

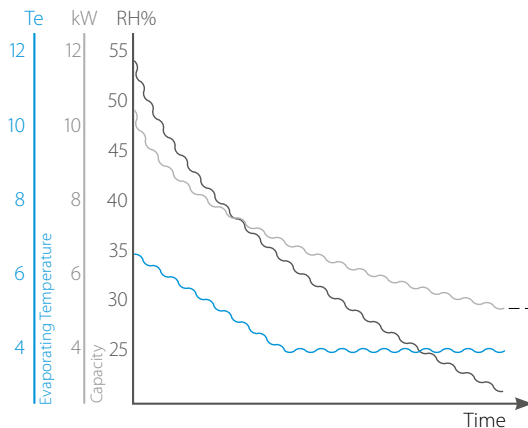

- Relative Humidity: ■ reduces over time
- Capacity: ■ reduced
- Evaporating temp: ■ drops to compensate reduced capacity
- too low Te can lead to freeze-up prevention, causing system downtime

Dedicated solution

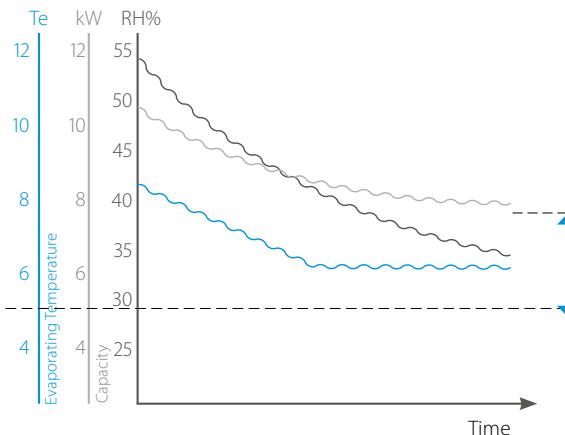

Improved solution

- 👍 Boosted capacity indoors increase the heat transfer capacity at low relative humidity
- 👍 Allows the system to operate with higher Te, guaranteeing continuous operation and reducing unwanted dehumidification

Between
20-40%
sensible capacity
increase

Up to 18%
savings on
running cost

Low humidity + Low ambient environment

Outside temperature Ta	-5 °C
Set-point	22 °C
Humidity	35 %
Indoor wet-bulb temperature	13 °C

EER

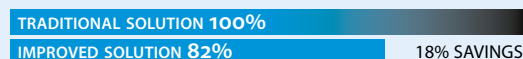

Traditional solution

RZAG71 + FAA71	
Total Capacity (TC)	5.63 kW
Sensible Heat Capacity (SHC)	4.28 kW
Power Input (PI)	2 kW
Co-efficient of Power Input (CPI)	0.39
Corrected PI	0.78 kW
EER*	5.5

Dedicated system combination solution

RZAG71 + FAA100	
Total Capacity (TC)	6.02 kW
Sensible Heat Capacity (SHC)	6.02 kW
Power Input (PI)	1.72 kW
Co-efficient of Power Input (CPI)	0.45
Corrected PI	0.77 kW
EER*	7.82

Sensible Heat Capacity increases **20-40%** with dedicated system combination.

*EER = (SHC/Corrected PI)

2-Step solution for system selection

High reliability for infrastructure cooling

UNIQUE

Select your infrastructure cooling system in 2 steps

No humidity generation in room (eg: Server room)

IT room requires 22°C inside. It will have 7kW of sensible cooling demand, and no latent cooling demand (no humidity generation) throughout the year. Ceiling suspended indoor unit is the customer's preference for the server room.

Indoor temperature = 22°CDB
 Sensible cooling demand (SHC) = 7 kW
 Latent cooling demand (LC) = 0 kW*
 Total cooling demand (TC) = SHC + LC = 7 kW
 Outdoor temperature operating range = -20°C ~ +40°C
 Most stringent outdoor unit capacity condition = -20°C

Solution
 Boosted capacity indoor combination with 10kW outdoor system.
 RZAG100 + FHA140
 Total capacity = 7.48 kW
 Sensible capacity = 7.48 kW
 Power input = 0.42 x 1.96 = 0.82 kW

* If there is no latent cooling demand, look for conditions where TC = SHC, since no more dehumidification will occur and thus the indoor environment will stabilize. When TC > SHC and there is no humidity generation, the indoor humidity will gradually decrease.

STEP 1
 Determine requested indoor conditions and required cooling demand (Sensible and Total capacity)

step 2
 Select the system combination from the given table, where the system's sensible and total capacity meets the cooling demand at the requested indoor and outdoor temperatures.

Some humidity source in room (eg: Laboratory)

Lab requires 22°C inside. It will have 9 kW of sensible cooling demand, and some humidity generation in the room (est. indoor humidity level 42%). Wall mounted indoor unit is the customer's preference for the laboratory.

Indoor temperature = 22°CDB
 Indoor Relative Humidity (RH%) = 42%**
 Sensible cooling demand (SHC) = 9 kW
 Latent cooling demand (LC) = 0.9 kW
 Total cooling demand (TC) = SHC + LC = 9.9 kW
 Outdoor temperature operating range = -20°C ~ +40°C
 Most stringent outdoor unit capacity condition = -20°C

Solution
 Boosted capacity indoor combination with 12.5kW outdoor system.
 RZAG125 + FAA71x2
 Total capacity = 10.39 kW
 Sensible capacity = 9.34 kW
 Power input = 0.46 x 2.65 = 1.22 kW

** System capacity at 42%RH (14.2°CWB) can be found by interpolation between 13°CWB (35%) and 15°CWB (48%).

Infrastructure cooling combination table



capacity class	FTXM-R				FAA-B				FHA-A(9)				FBA-A(9)				FDXM-F9				FUA-A				FNA-A9				FVA-A				FFA-A9				FCAHG-H				FCAG-B			
	35	50	60	71	71	100	35	50	60	71	100	125	140	35	50	60	71	100	125	140	35	50	60	71	100	125	140	35	50	60	71	100	125	140	35	50	60	71	100	125	140			
RZAG35A		P						P								P																												
RZAG50A			P						P							P																												
RZAG60A				P						P							P																											
RZAG71NV1							P	3	2		P						3	2		P																								
RZAG71NY1																																												
RZAG100NV1							2	4	3		2				P	4	3		2			P	4	3		2																		
RZAG100NY1																																												
RZAG125NV1							2	4	3		2				P	4	3		2			P	4	3		2																		
RZAG125NY1																																												
RZAG140NV1							2	4	3		2				P	4	3		2			P	4	3		2																		
RZAG140NY1																																												

P = Pair, 2 = Twin, 3 = Triple, 4 = Double twin; For more information on infrastructure cooling options refer to infrastructure cooling catalogue.

Boosted capacity indoor unit with 7kW outdoor system

RZAG71NV1 / RZAG71NY1

Performance characteristics for ·EDP· room

Indoor	Outdoor temperature [°C DBI]																																						
	-20			-15			-10			-5			0			5			10			15			20			25			30			35			40		
	TC	SHC	CPI	TC	SHC	CPI	TC	SHC	CPI	TC	SHC	CPI	TC	SHC	CPI	TC	SHC	CPI	TC	SHC	CPI	TC	SHC	CPI	TC	SHC	CPI	TC	SHC	CPI	TC	SHC	CPI	TC	SHC	CPI	TC	SHC	CPI
RH[%] °CWB °CDB																																							
41.8 11	18																																						
57.0 13	20																																						
31.4 11	22																																						
44.9 13	24																																						
52.0 14	27																																						
22.9 11	18																																						
34.8 13	20																																						
47.6 15	22																																						
54.3 16	24																																						
21.2 12	27																																						
32.1 14	18																																						
43.8 16	20																																						
50.0 17	22																																						
21.5 14	24																																						
26.3 15	27																																						
31.3 16	18																																						

Pair	FCAHG100H	FCAG100B	FAA100B	FVA100A	FHA100A	FUA100A	FBA100A
Cooling	1.64	1.64	1.96	1.72	1.69	1.69	1.64
Twin	FCAG50Bx2	FHA50Ax2	FFA50Ax2	FDXM50Fz2	FBA50Ax2		
Cooling	1.56	1.70	1.79	1.44	1.67		
Triple	FCAG35Bx3	FHA35Ax3	FFA35Ax3	FDXM35Fz3	FBA35Ax3		
Cooling	1.51	1.51	1.62	1.51	1.64		

3D125184B

Boosted capacity indoor unit with 10kW outdoor system

RZAG100NV1 / RZAG100NY1

Performance characteristics for ·EDP· room

Indoor	Outdoor temperature [°C DBI]																																						
	-20			-15			-10			-5			0			5			10			15			20			25			30			35			40		
	TC	SHC	CPI	TC	SHC	CPI	TC	SHC	CPI	TC	SHC	CPI	TC	SHC	CPI	TC	SHC	CPI	TC	SHC	CPI	TC	SHC	CPI	TC	SHC	CPI	TC	SHC	CPI	TC	SHC	CPI	TC	SHC	CPI	TC	SHC	CPI
RH[%] °CWB °CDB																																							
41.8 11	18																																						
57.0 13	20																																						
31.4 11	22																																						
44.9 13	24																																						
52.0 14	27																																						
22.9 11	18																																						
34.8 13	20																																						
47.6 15	22																																						
54.3 16	24																																						
21.2 12	27																																						
32.1 14	18																																						
43.8 16	20																																						
50.0 17	22																																						
21.5 14	24																																						
26.3 15	27																																						
31.3 16	18																																						

Pair	FCAHG140H	FCAG140B	FVA140A	FHA140A	FBA140A	
Cooling	2.35	2.28	2.39	2.32	2.25	
Twin	FCAHG71Hx2	FCAG71Bx2	FHA71Ax2	FUA71Ax2	FAA71Bx2	FBA71Ax2
Cooling	2.02	2.15	2.10	2.11	2.19	2.06

Triple	FCAG50Bx3	FHA50Ax3	FFA50Ax3	FDXM50Fz3	FBA50Ax3
Cooling	2.03	2.18	2.25	1.88	2.18
Double twin	FCAG35Bx4	FHA35Ax4	FFA35Ax4	FDXM35Fz4	FBA35Ax4
Cooling	2.00	2.01	2.12	2.00	2.18

3D125185A

Notes

- The ratings shown are net capacities which include a deduction for indoor fan motor heat.
- The capacities are based on the following conditions:
 - Outdoor air: ·85% RH·
 - Corresponding refrigerant piping length: ·5.0· m
 - Level difference: ·0·m
- For ·EDP· applications, it is recommended to use outdoor unit setting ·2·-57·-2·.
- CPI· is a percentage value compared to the rated value which is ·1.00·.
- The error rate for this value is less than ·5·% and depends on the indoor unit type.
- The rated power input (PI) for each model is mentioned in the table below.

Symbols

TC	: Maximum total cooling capacity	[kW]
SHC	: Sensible heat capacity	[kW]
CPI	: Coefficient of the power input	
PI	: Power input	[kW]
	compressor + indoor and outdoor fan motors	
RH	: Relative humidity	[%]



Sky Air Alpha-series

Industry leading technology for commercial applications and even for technical rooms

- Unique, low-height single fan range
- Compact dimensions allow almost unnoticeable installation
- Market-leading serviceability and handling, thanks to wide access area, 7-segment display and additional handle
- The perfect balance in efficiency and comfort thanks to Variable Refrigerant Temperature: top seasonal efficiency throughout most of the year and quick reaction speed on the hottest days.
- Suits high sensible, infrastructure cooling applications
- Replace existing systems with R-32 technology without needing to replace the piping
- Guarantees operation in both heating and cooling mode down to -20°C
- Refrigerant cooled PCB guarantees reliable cooling, as it is not influenced by ambient temperature.
- Maximum piping length up to 85m (50m for RZAG-A)
- Outdoor units for pair, twin, triple, double twin application
- Combines with EKLN-A low sound enclosure

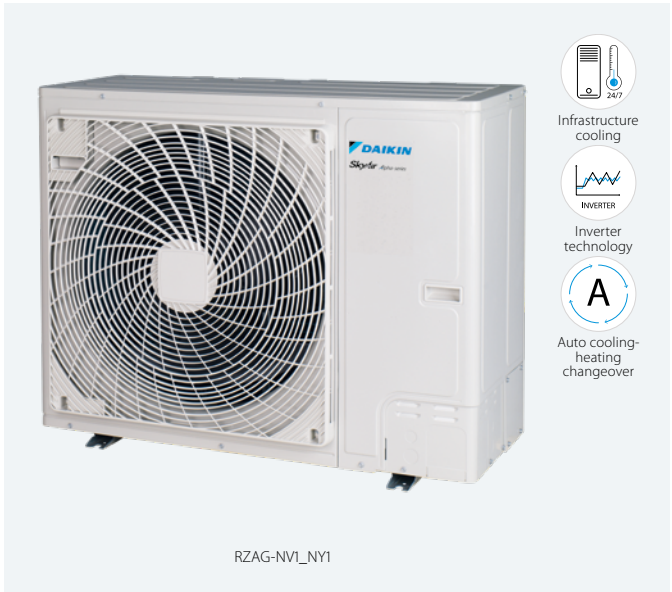

Comfort cooling combination table

	FCAHG-H				FCAG-B				FFA-A9			FDA-A			FDXM-F9			FBA-A(9)				FHA-A(9)				FAA-B		FTXM-R			FUA-A			FNA-A9			FVA-A										
capacity class	71	100	125	140	35	50	60	71	100	125	140	35	50	60	71	100	125	140	35	50	60	71	100	125	140	35	50	60	71	100	125	140	71	100	125	140	35	50	60	71	100	125	140				
RZAG35A																																															
RZAG50A																																															
RZAG60A																																															
RZAG71NV1																																															
RZAG100NV1																																															
RZAG125NV1																																															
RZAG140NV1																																															

P = pair application; 2/3/4 = twin/triple/double twin application

Infrastructure cooling combination table

	FTXM-R				FAA-B			FHA-A(9)				FBA-A(9)				FDXM-F9				FUA-A				FNA-A9			FVA-A				FFA-A9			FCAHG-H				FCAG-B								
capacity class	35	50	60	71	71	100	100	35	50	60	71	100	125	140	35	50	60	71	100	125	140	35	50	60	71	100	125	140	35	50	60	71	100	125	140	35	50	60	71	100	125	140				
RZAG35A																																														
RZAG50A																																														
RZAG60A																																														
RZAG71NV1																																														
RZAG100NV1																																														
RZAG125NV1																																														
RZAG140NV1																																														

P = Pair, 2 = Twin, 3 = Triple, 4 = Double twin; For more information on infrastructure cooling options refer to infrastructure cooling catalogue.

		RZAG				RZAG-NV1				RZAG-NY1							
Outdoor unit		35A	50A	60A	71NV1	100NV1	125NV1	140NV1	71NY1	100NY1	125NY1	140NY1					
Dimensions	Unit	734x870x373				870x1,100x460											
Weight	Unit	52				95											
Sound power level	Cooling	62.0	63.0	64.0	64	85	69	70	64	66	69	70					
	Heating	62.0	63.0	64.0	-	-	68(1)	71(1)	-	-	68(1)	71(1)					
Sound pressure level	Cooling Nom.	48.0	49.0	50.0	46	47	49	50	46	47	49	50					
	Heating Nom.	48.0	49.0	50.0	48	50	52	48	50	52	49	50					
Operation range	Cooling Ambient Min.~Max.	-20~52				-20~52											
	Heating Ambient Min.~Max.	-20~24				-20~18											
Refrigerant	Type/GWP	R-32/675.0				R-32/675											
	Charge	1.55/1.05				3.20/2.16											
Piping connections	Liquid/Gas OD	6.35/9.52				9.52/15.9											
	Piping length	50				85											
	OU - IU Max. Equivalent Chargeless	30				40											
	Level difference IU - OU Max.	30.0				30											
	Additional refrigerant charge	0.02 (for piping length exceeding 30m)				See installation manual											
Power supply	Phase/Frequency/Voltage	1~/50 /220-240				3~/50 /380-415											
Current - 50Hz	Maximum fuse amps (MFA)	-				20				32				16			

(1)According to ENER Lot 21 | Contains fluorinated greenhouse gases

Sky Air Advance-series

Technology and comfort combined for commercial applications

- High efficiency:
- Energy labels up to A++ (cooling) / A+ (heating)
- Compressor offers substantial efficiency improvements
- Very compact and easy to install
- Replace existing systems with R-32 technology without needing to replace the piping
- Guarantees operation in both heating and cooling mode down to -15°C
- Refrigerant cooled PCB guarantees reliable cooling, as it is not influenced by ambient temperature.
- Maximum piping length up to 50m, minimum piping length has no limitation
- Outdoor units for pair, twin, triple, double twin application

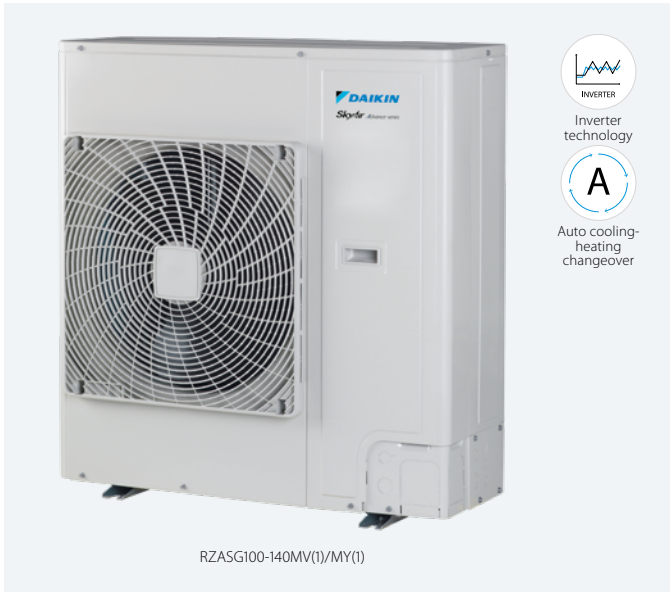

RZASG100-140MV(1)/MY(1)

Pair, twin, triple and double twin application

capacity class	FCAG-B						FFA-A9			FDXM-F9			FBA-A(9)								
	35	50	60	71	100	125	140	35	50	60	35	50	60	35	50	60	71	100	125	140	
RZASG71MV1				P				2			2			2			P				
RZASG100MV(1)	RZASG100MY(1)	3	2			P		3	2		3	2		3	2				P		
RZASG125MV(1)	RZASG125MY(1)	4	3	2			P	4	3	2	4	3	2	4	3	2				P	
RZASG140MV(1)	RZASG140MY(1)	4	3		2		P	4	3		4	3		4	3		2				P

capacity class	FDA-A	FHA-A(9)						FUA-A			FAA-B		FVA-A				FNA-A9						
	125	35	50	60	71	100	125	140	71	100	125	71	100	71	100	125	140	35	50	60			
RZASG71MV1			2			P						P											
RZASG100MV(1)	RZASG100MY(1)		3	2			P				P			P			P				3	2	
RZASG125MV(1)	RZASG125MY(1)	P	4	3	2			P			P						P				4	3	2
RZASG140MV(1)	RZASG140MY(1)		4	3		2		P	2			2			2			P			4	3	

P = Pair, 2 = Twin, 3 = Triple, 4 = Double twin

RZASG-MV1 RZASG-MY1 RZASG-MV RZASG-MY

Outdoor unit		RZASG		71MV1	100MV(1)	125MV(1)	140MV(1)	100MY(1)	125MY(1)	140MY(1)	
Dimensions	Unit	HeightxWidthxD	mm	770x900x320			990x940x320				
Weight	Unit		kg	60	70 (MY1)/72 (MY)		78 (MV1)/79 (MV)	70 (MY1)/72 (MY)		78 (MV1)/79 (MV)	
Sound power level	Cooling		dBA	65	70	71	73	70	71	73	
	Heating		dBA			71(1)	73(1)		71(1)	73(1)	
Sound pressure level	Cooling	Nom.	dBA	46	53		54	53		54	
	Heating	Nom.	dBA	47	57						
Operation range	Cooling	Ambient	Min.~Max.	°CDB			-15~46				
	Heating	Ambient	Min.~Max.	°CWB			-15~-15.5				
Refrigerant	Type/GWP			R-32/675							
	Charge		kg/TCO2Eq	2.45/1.65	2.60/1.76		2.90/1.96	2.60/1.76		2.90/1.96	
Piping connections	Liquid/Gas	OD	mm	9.52/15.9							
	Piping length	OU - IU	Max.	m							
		System	Equivalent	m							
			Chargeless	m							
		Additional refrigerant charge		kg/m	See installation manual						
Power supply	Phase/Frequency/Voltage		Hz/V	1~/50 /220-240				3~/50 /380-415			
	Current - 50Hz	Maximum fuse amps (MFA)	A	20	25	32		16			

(1)According to ENER Lot 21 | Contains fluorinated greenhouse gases

Sky Air Advance-series

R-32

SkyAir Advance-series
BLUEEVOLUTION

Large Sky Air system for commercial applications in the most compact casing ever

- Compact (870mm high) and lightweight single fan design makes the unit unobtrusive, saves space and is easy to install
- Market-leading serviceability and handling, thanks to wide access area, 7-segment display and additional handle
- Choosing for an R-32 product, reduces the environmental impact with 68% compared to R-410A, leads directly to lower energy consumption thanks to its high energy efficiency and has a lower refrigerant charge
- Replace existing systems with R-32 technology without needing to replace the piping
- Guarantees operation in heating mode down to -20°C
- Refrigerant cooled PCB guarantees reliable cooling, as it is not influenced by ambient temperature.
- Maximum piping length up to 100m
- Maximum installation height difference up to 30m
- Outdoor units for pair, twin, triple, double twin application
- Combines with EKLN-A low sound enclosure

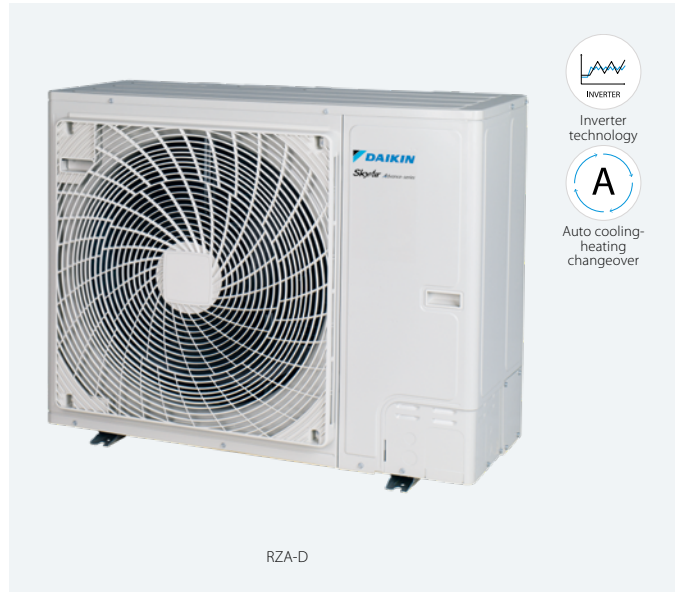

RZA-D

Comfort cooling combination table

capacity class	FCAG-B					FFA-A9				FDXM-F9				FBA-A(9)					FHA-A(9)					FDA-A			FUA-A			FAA-B			FVA-A			FNA-A9	
	50	60	71	100	125	50	60	50	60	50	60	71	100	125	50	60	71	100	125	125	200	250	71	100	125	71	100	71	100	71	100	125	50	60			
RZA200D	4	3	3	2		4	3	4	3	4	3	3	2		4	3	3	2					P			3	2		3	2	3	2	3	2		4	3
RZA250D		4			2		4		4		4			2		4			2	2		P						2					2		4		

P = pair application

RZA-D

Outdoor unit		RZA		200D		250D	
Dimensions	Unit	HeightxWidthxDepth	mm	870x1,100x460			
Weight	Unit		kg	117			
Sound power level	Cooling		dBA	73		76	
	Heating		dBA	76		79	
Sound pressure level	Cooling	Nom.	dBA	53		57	
	Heating	Nom.	dBA	60		63	
Operation range	Cooling	Ambient	Min.~Max.	°CDB -20~46			
	Heating	Ambient	Min.~Max.	°CWB -20~15			
Refrigerant	Type/GWP	R-32/675					
	Charge		kg/TCO2Eq	5/3.38			
Piping connections	Liquid/Gas	OD	mm	9.52/22.2			
	Piping	OU - IU	Max.	m 100			
	length	System	Chargeless	m 30			
	Additional refrigerant charge		kg/m	See installation manual			
Power supply	Phase/Frequency/Voltage	Hz/V 3~/50 /380-415					
Current - 50Hz	Maximum fuse amps (MFA)	A 20					

Contains fluorinated greenhouse gases

Sky Air Active-series

Ideal solution for busy environments and small shops

- High efficiency:
 - Energy labels up to A+ (cooling) / A (heating)
 - compressor offers substantial efficiency improvements
- Choosing for an R-32 product, reduces the environmental impact with 68% compared to R-410A and leads directly to lower energy consumption thanks to its high energy efficiency
- Very compact and easy to install
- Replace existing systems with R-32 technology without needing to replace the piping



- Guarantees operation in heating mode down to -15°C and in cooling mode down to -10°C
- Refrigerant cooled PCB guarantees reliable cooling, as it is not influenced by ambient temperature.
- Piping length up to 30m
- Exclusively offered for pair applications



AZAS100-140MV_MY

Pair application

capacity class	FCAG-B				FBA-A(9)				FAA-B				FHA-A(9)				FVA-A				ADEA-A		
	71	100	125	140	71	100	125	140	71	100	125	140	71	100	125	140	71	100	125	140	71	100	125
ARXM-R	P				P				P														
AZAS-MV		P	P	P		P	P	P		P			P	P	P		P	P	P			P	P
AZAS-MY		P	P	P		P	P	P		P			P	P	P		P	P	P				

P = pair application

ARXM-R AZAS-MV AZAS-MY

Outdoor Unit				ARXM71R	AZAS100MV	AZAS125MV	AZAS140MV	AZAS100MY	AZAS125MY	AZAS140MY	
Dimensions	Unit	HeightxWidthxDepth	mm	734x954x401	990x940x320						
Weight	Unit		kg	49.0	72		79	72		79	
Sound power level	Cooling		dBA	-	70	71	73	70	71	73	
	Heating		dBA	-	70	71	73	70	71	73	
Sound pressure level	Cooling	Nom.	dBA	52.0	53		54	53		54	
	Heating	Nom.	dBA	52.0	57						
Operation range	Cooling	Ambient	Min.~Max.	°CDB	-10~46						
	Heating	Ambient	Min.~Max.	°CWB	-15~24	-15~15.5					
Refrigerant	Type/GWP				R-32/675						
	Charge		kg/TCO2Eq	1.15/0.780	2.60/1.76		2.90/1.96	2.60/1.76		2.90/1.96	
Piping connections	Liquid/Gas	OD	mm	9.52/15.9							
	Piping length	OU - IU	Max.	m	30						
		System	Equivalent	m	-	50					
			Chargeless	m	-	30					
		Additional refrigerant charge	kg/m	0.035 <small>(for piping length exceeding 10m)</small>	See installation manual						
	Level difference IU - OU	Max.	m	30.0							
Power supply	Phase/Frequency/Voltage		Hz/V	1~/50/220-240				3~/50/380-415			
Current - 50Hz	Maximum fuse amps (MFA)		A	-	25	32		16			

Contains fluorinated greenhouse gases



Wide range
of R-32 rooftop units
to cover your needs

Rooftop

Why choose Daikin Rooftop series	88
UATYA-BBAY1	90
UATYA-BFC2Y1	90
UATYA-BFC3Y1	91
UATYA-BRS4	91



Wide range of R-32 rooftop units to cover your needs



Made-To-Stock units (MTS)

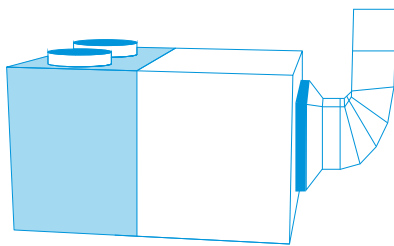

48 predefined units readily available from stock

- Fast delivery
- 3 versions: Base, 2 dampers and 3 dampers
 - Thermodynamic heat recovery available on full FC3 range
- Capacity up to 190 kW!
- Comes with a wide range of standard integrated features

Made-To-Order units (MTO)

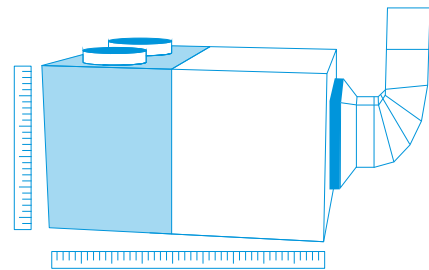

Fully customizable units for maximum flexibility

- Almost infinite configuration possibilities thanks to wide choice of options
- 4 versions: Base, 2 dampers, 3 dampers and 4 dampers
 - Thermodynamic heat recovery available on full FC3 range
 - Premium efficiency plate heat exchanger available on RS4 range
- Capacity up to 190 kW!
- Comes with a wide range of standard integrated features
- Easy selection via selection software: rooftop.daikin.eu

Products overview rooftops

Capacity class (kW)

Type	Model	MTS Product name	Refrigerant	Version	25	30	40	50	60	70	80	90	100	110	120	140	150	160	180	190		
Air cooled Heat pump	Rooftop unit With extensive base package for high installation flexibility and easy servicing ▪ 'Plug and play' for easy installation ▪ High efficiency ▪ Flexible supply and return air direction ▪ Direct integration with Daikin or third party BMS ▪ Factory pre-charged refrigerant	UATYA-BBAY1	R-32	MTS MTO	•	•	•	•	•	•	•	•	•	•	•	•	•	•	•	•		
	Rooftop unit 2 damper version with integrated fresh air ▪ Free cooling with up to 100% fresh air intake ▪ Comes with all Base model features	UATYA-BFC2Y1		MTS MTO	•	•	•	•	•	•	•	•	•	•	•	•	•	•	•	•	•	
	Rooftop unit 3 damper version with integrated fresh air and extraction ▪ Integrated extraction damper eliminates over-pressure ▪ Thermodynamic heat recovery, recovering waste heat ▪ Comes with all FC2 model features	UATYA-BFC3Y1		MTS MTO	•	•	•	•	•	•	•	•	•	•	•	•	•	•	•	•	•	•
	Rooftop unit 4 damper version with integrated fresh air, extraction and plate heat exchanger ▪ Premium efficiency plate heat exchanger, recovering waste heat ▪ Comes with all FC3 model features	UATYA-BRS4*		MTS MTO	•	•	•	•	•	•	•	•	•	•	•	•	•	•	•	•	•	•

* Indicative model name. Correct model name to be retrieved from selection software.

Standard integrated features on all Made-To-Stock and Made-To-Order units

1 R-32 refrigerant

- Top sustainability thanks to the use of low GWP (675) refrigerant
- Single component refrigerant, easy to re-use and recycle



BLUEEVOLUTION

2 Inverter driven compressors

- Great year-round seasonal efficiency
- Available up to 120 kW models

3 Capacity range up to 190 kW!

- More flexibility to tackle larger projects with a small footprint

4 25 mm double skinned panels

- Ensuring long-lasting life and providing good thermal and sound insulation



5 Full color touch display

- Intuitive to use
- Better visualisation of unit parameters



6 Integrated connectivity

- Integration into Daikin intelligent Touch Manager BMS (via BACNET protocol)
- Integration in 3rd party BMS systems via Ethernet port (BACnet TCP/IP & Modbus TCP/IP) or 3-cable port (Modbus over RS485)



7 Selection software

- Easy selection of the correction unit and options based on location conditions
- Direct availability of technical drawings

More standard integrated features

- ISO Coarse 75% filter (G4) (standard for MTS only)
- Standard clogged filter alarm
- Flexible air delivery
- Hydrophilic aluminum fins on indoor and outdoor unit side
- Mesh coil guard on outdoor heat exchanger
- Factory mounted drain pan with heater
- Single operation voltage-free contact
- Power supply connection safety through max/min voltage relay and reversed phase connection

8 BIM objects

- All made to stock units available as Revit, IFC, Archicad and AutoCAD files
- All made to order units available as Revit

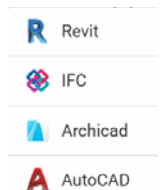

Download our objects now!
bim.daikin.eu



4 versions to choose from

UATYA-BBAY1

High installation flexibility and easy servicing

- Easy to install 'plug and play' concept plus single installation configuration; no additional piping is required since indoor and outdoor sides are pre-connected
- High efficiency and reliable scroll compressor
- Factory pre-charged refrigerant ensures clean and efficient operation

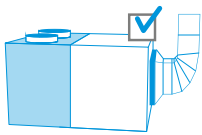

Made-To-Stock units (MTS)

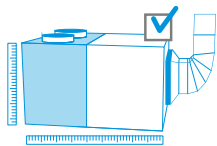

Made-To-Order units (MTO)

HEATING operation example

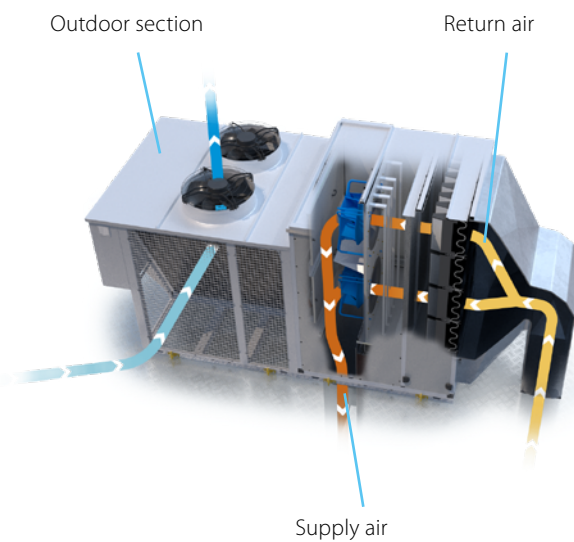

UATYA-BFC2Y1

2 damper version, with integrated fresh air

- Free cooling with up to 100% fresh air possible
 - Improved air quality
 - Energy saving using fresh outdoor air to cool the building
- Includes all Base model features

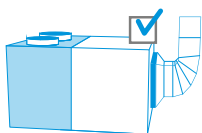

Made-To-Stock units (MTS)

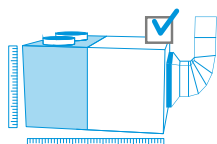

Made-To-Order units (MTO)

HEATING operation example

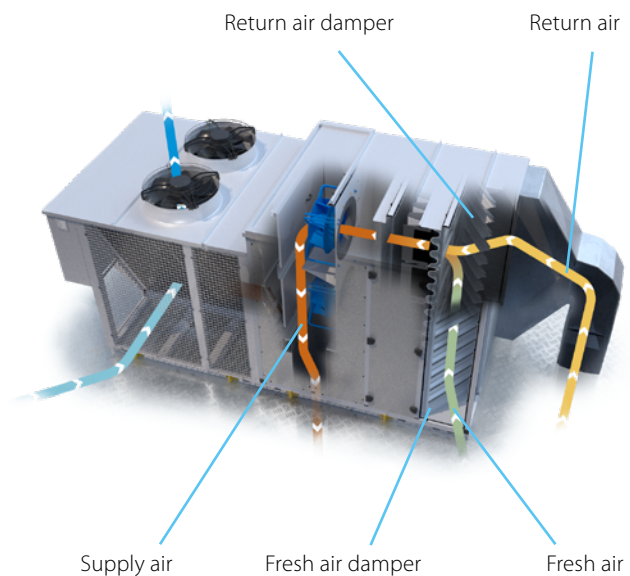

3 damper version, with integrated fresh air and extraction

- Extraction damper integrated
 - Eliminates excessive overpressure in the building
 - Including high efficient extraction fan for optimum air circulation in larger buildings
- Thermodynamic heat recovery
 - Saves energy by recovering waste heat through the outdoor heat exchanger
 - Available on all models
- Includes all FC2 model features

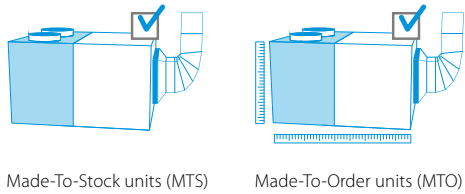

Heating operation example

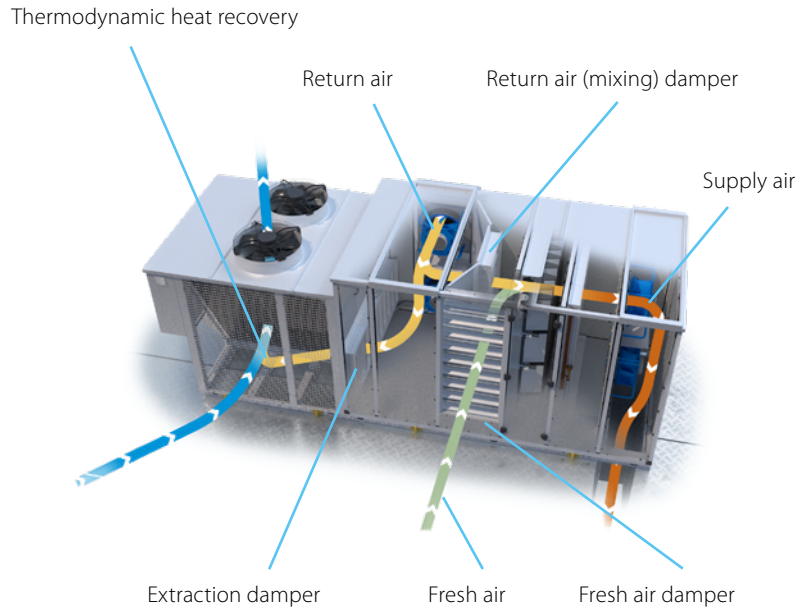

4 damper version, with integrated fresh air, extraction and plate heat recovery

- Premium efficiency counter flow plate heat exchanger
 - Recovers up to 58% waste heat from the return air
 - Available in 50% and 100% return air heat recovery
- Bypass damper to allow plate heat exchange or free cooling
- Additional thermodynamic heat recovery available up to 50kW models
- Includes all FC3 model features
- Only available as Made-To-Order model

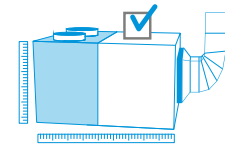

Made-To-Order units (MTO) only

* Indicative model name. Correct model name to be retrieved from selection software.

Plate heat recovery mode in heating operation

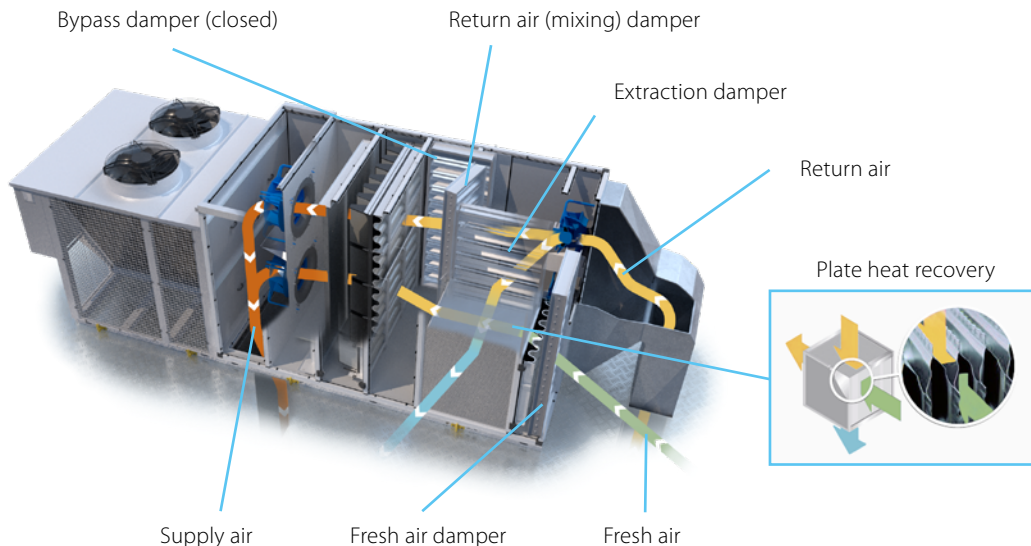

Specifications Made-To-Stock units

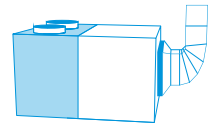

UATYA-BBAY1



UATYA-BBAY1



UATYA20-30BBAY1

Indoor Unit		UATYA																	
		25	30	40	50	60	70	80	90	100	110	120	140	150	160	180	190		
Cooling capacity	Nom.	kW																	
Heating capacity	Nom.	kW																	
EER		2.83 3.09 3.06 2.96 3.12 2.92 3.09 3.06 2.97 2.99 2.91 3.14 3.02 3.05 3.07 2.97																	
COP		3.22 3.31 3.26 3.24 3.25 3.21 3.37 3.22 3.20 3.35 3.25 3.44 3.33 3.26 3.33 3.27																	
Space cooling	Capacity Pdesign	kW																	
	SEER	4.52 4.79 5.39 5.26 5.50 4.53 5.56 5.47 5.17 5.29 5.15 4.38 4.26 4.27 4.15 4.08																	
	ηs,c	%																	
Space heating (Average climate)	Capacity Pdesign	kW																	
	SCOP/A	3.35 3.38 3.67 3.65 3.47 3.41 3.70 3.65 3.62 3.56 3.53 3.39 3.36 3.34 3.31 3.34																	
	ηs,h	%																	
Evaporator	Supply side	Air discharge direction																	
	Fan	Bottom, Right, Left																	
		Air flow rate	m³/h																
		Nominal ESP	Pa																
	Return side	Air intake direction - Air discharge direction																	
Supply side	Thermodynamic heat recovery - Air discharge direction																		
Fresh air - Supply side	Standard - Air discharge direction																		
Condenser	Air flow rate Cooling	m³/h																	
	Refrigerant	GWP																	
	Charge	kg																	
Dimensions	Unit	Height																	
		mm																	
		Width																	
		mm																	
	Depth	mm																	
Weight	Unit	kg																	
Casing	Colour	RAL 7035																	
Sound pressure level	Cooling	dBA																	
Sound power level	Cooling	dBA																	
Operation range	Cooling	Min. ~ Max. °CDB																	
	Heating	Min. ~ Max. °CWB																	
Power supply	Phase/Frequency/Voltage	Hz/V																	
Current	Recommended fuses	A																	

UATYA-BFC2Y1



UATYA-BFC2Y1

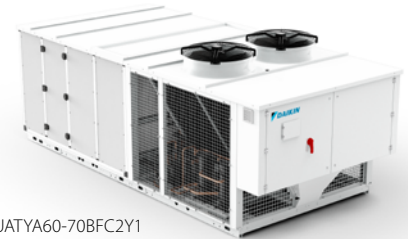

UATYA60-70BFC2Y1

Indoor Unit		UATYA																	
		25	30	40	50	60	70	80	90	100	110	120	140	150	160	180	190		
Cooling capacity	Nom.	kW																	
	With 30% fresh air	kW																	
Heating capacity	Nom.	kW																	
	With 30% fresh air	kW																	
EER		2.83/2.96 3.09/3.26 3.06/3.21 2.96/3.10 3.12/3.28 2.92/3.06 3.09/3.26 3.06/3.24 2.97/3.13 2.99/3.13 2.91/3.03 3.14/3.29 3.02/3.16 3.05/3.19 3.07/3.21 2.97/3.10																	
COP		3.22/3.43 3.31/3.53 3.26/3.48 3.24/3.51 3.25/3.47 3.21/3.44 3.37/3.62 3.22/3.47 3.20/3.46 3.35/3.60 3.25/3.48 3.44/3.69 3.33/3.57 3.26/3.50 3.33/3.58 3.27/3.55																	
Space cooling	Capacity Pdesign	kW																	
	SEER	4.52 4.79 5.39 5.26 5.50 4.53 5.56 5.47 5.17 5.29 5.15 4.38 4.26 4.27 4.15 4.08																	
	ηs,c	%																	
Space heating (Average climate)	Capacity Pdesign	kW																	
	SCOP/A	3.35 3.38 3.67 3.65 3.47 3.41 3.70 3.65 3.62 3.56 3.53 3.39 3.36 3.34 3.31 3.34																	
	ηs,h	%																	
Evaporator	Supply side	Air discharge direction																	
	Fan	Frontal, Left																	
		Air flow rate	m³/h																
		Nominal ESP	Pa																
	Return side	Air intake direction - Air discharge direction																	
Supply side	Thermodynamic heat recovery - Air discharge direction																		
Fresh air - Supply side	Standard - Air discharge direction																		
Fresh air	Ratio	Standard																	
	In free cooling	%																	
Condenser	Air flow rate Cooling	m³/h																	
	Refrigerant	GWP																	
	Charge	kg																	
Dimensions	Unit	Height																	
		mm																	
		Width																	
		mm																	
	Depth	mm																	
Weight	Unit	kg																	
Casing	Colour	RAL 7035																	
Sound pressure level	Cooling	dBA																	
Sound power level	Cooling	dBA																	
Operation range	Cooling	Min. ~ Max. °CDB																	
	Heating	Min. ~ Max. °CWB																	
Power supply	Phase/Frequency/Voltage	Hz/V																	
Current	Recommended fuses	A																	

UATYA-BFC3Y1



UATYA-BFC3Y1



UATYA80-120BFC3Y1

Indoor Unit		UATYA	25	30	40	50	60	70	80	90	100	110	120	140	150	160	180	190																															
Cooling capacity	Nom.	kW	24.1	31.3	38.7	45.7	58.8	65.3	74.8	89.8	95.8	108.9	115.0	133.4	144.7	154.6	171.9	187.0																															
	With 30% fresh air	kW	26.0	33.9	42.5	49.6	63.7	70.5	81.3	96.8	104.3	118.0	124.5	145.6	156.8	168.3	186.5	204.4																															
Heating capacity	Nom.	kW	24.0	29.5	36.3	46.2	55.1	64.9	68.5	84.2	92.8	101.5	108.0	123.1	136.4	147.1	157.1	176.9																															
	With 30% fresh air	kW	25.0	31.0	38.3	47.7	57.1	68.6	71.6	87.2	97.9	107.0	112.3	132.0	147.5	160.0	173.5	191.6																															
EER			2.83/2.96	3.09/3.20	3.06/3.27	2.96/3.12	3.12/3.23	2.92/3.00	3.09/3.21	3.06/3.22	2.97/3.14	2.99/3.11	2.91/3.01	3.14/3.26	3.02/3.14	3.05/3.18	3.07/3.21	2.97/3.14																															
COP			3.22/3.41	3.31/3.50	3.26/3.51	3.24/3.46	3.25/3.40	3.21/3.39	3.37/3.56	3.22/3.45	3.20/3.42	3.35/3.57	3.25/3.40	3.44/3.62	3.33/3.57	3.26/3.49	3.33/3.63	3.27/3.50																															
Space cooling	Capacity Pdesign	kW	24.1	31.3	38.7	45.7	58.8	65.3	74.8	89.8	95.8	108.9	115.0	133.4	144.7	154.6	171.9	187.0																															
	SEER		4.52	4.79	5.39	5.26	5.50	4.53	5.56	5.47	5.17	5.29	5.15	4.38	4.26	4.27	4.15	4.08																															
	ηs,c	%	177.8	188.6	212.5	207.0	217.1	178.1	219.4	215.8	203.7	208.6	203.0	172.1	167.2	167.6	162.8	160.2																															
Space heating (Average climate)	Capacity Pdesign	kW	24.0	29.5	36.3	46.2	55.1	64.9	68.5	84.2	92.8	101.5	108.0	123.1	136.4	147.1	157.1	176.9																															
	SCOP/A		3.35	3.38	3.67	3.65	3.47	3.41	3.70	3.65	3.62	3.56	3.53	3.39	3.36	3.34	3.31	3.34																															
	ηs,h	%	131.0	132.2	143.8	143.0	135.6	133.5	145.2	143.0	141.6	139.3	138.3	132.5	131.4	130.8	129.5	130.6																															
Evaporator	Supply side	Air discharge direction	Frontal, Left						Bottom, Right, Left, Frontal																																								
		Fan	Air flow rate	4,500	5,800	7,500	9,000	11,000	13,000	14,500	16,500	18,000	19,800	21,600	25,000	26,500	28,000	30,500	31,500																														
			Nominal ESP	300																																													
	Return side	Air intake direction - Air discharge direction	Rear						Right																																								
	Supply side	Fan	Air flow rate	4,500	5,800	7,500	9,000	11,000	13,000	14,500	16,500	18,000	19,800	21,600	25,000	26,500	28,000	30,500	31,500																														
			Nominal ESP	300																																													
	Return side	Thermodynamic heat recovery - Air discharge direction	Yes																																														
	Supply side	Standard - Air discharge direction	Yes																																														
	Fresh air	Ratio	Standard	30																																													
		In free cooling	%	100																																													
Condenser	Air flow rate Cooling	m ³ /h	15,725	16,038	16,374	16,341	31,183	32,203	35,774	37,285	36,195	38,143	36,865	70,704	72,395	67,733	70,200	72,005																															
	Refrigerant	Charge	kg	7.0	10.0	12.0	15.0	18.0	23.0	24.0	28.0	30.0	36.0	38.0	46.0	50.0																																	
Dimensions	Unit	Height	1,924			2,374			1,924			2,250																																					
		Width	3,514						6,317						7,117																																		
		Depth	1,166			1,196			1,310			1,329			1,996			2,094			2,336			2,382			2,452			2,548			2,558			3,024			3,035			3,074			3,192			3,271	
Weight	Unit	Colour	RAL 7035																																														
Casing	Sound pressure level	Cooling	dB(A)	63.9	66.0	68.0	67.3	69.0	68.1	72.6	68.7	69.9	70.6	74.2	68.3	68.7	69.1	70.0																															
	Sound power level	Cooling	dB(A)	82.2	84.3	86.8	86.1	88.5	87.5	92.5	88.6	89.8	90.5	94.1	88.6	89.0	89.3	90.2																															
Operation range	Cooling	Min. ~ Max.	°CDB	-10 ~ 48																																													
	Heating	Min. ~ Max.	°CWB	-15 ~ 26																																													
Power supply	Phase/Frequency/Voltage	Hz/V	3~/50 /400																																														
Current	Recommended fuses	A	25	40	50	63	80	100	160	200																																							

Specifications Made-To-Order units

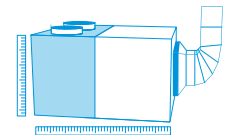

All naming in the tables above is valid for Made-To-Stock units only.

For specifications and configuration of Made-To-Order units refer to our selection software.

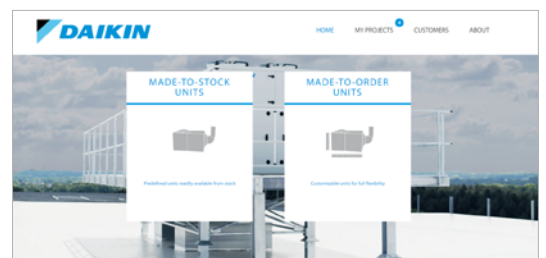



Commercial ventilation

Decentralised ventilation	96
▪ VAM-FC9/J Energy recovery ventilation	96
▪ EKVDX DX coil for air processing	97
▪ ALB-LBS/RBS Modular L Smart	98
▪ ATB-S Modular T Smart	99
Centralised ventilation	100
▪ Combining Air Handling Units with DX outdoor units	100
▪ Daikin Air Handling Unit kits for connection to DX outdoor units	NEW 101
▪ Air Handling Unit kits – Layout possibilities	102
▪ Daikin Fresh Air package	103
Commercial air purifiers	104
▪ Astropure – BR00000554/676/749/751	105

Products overview

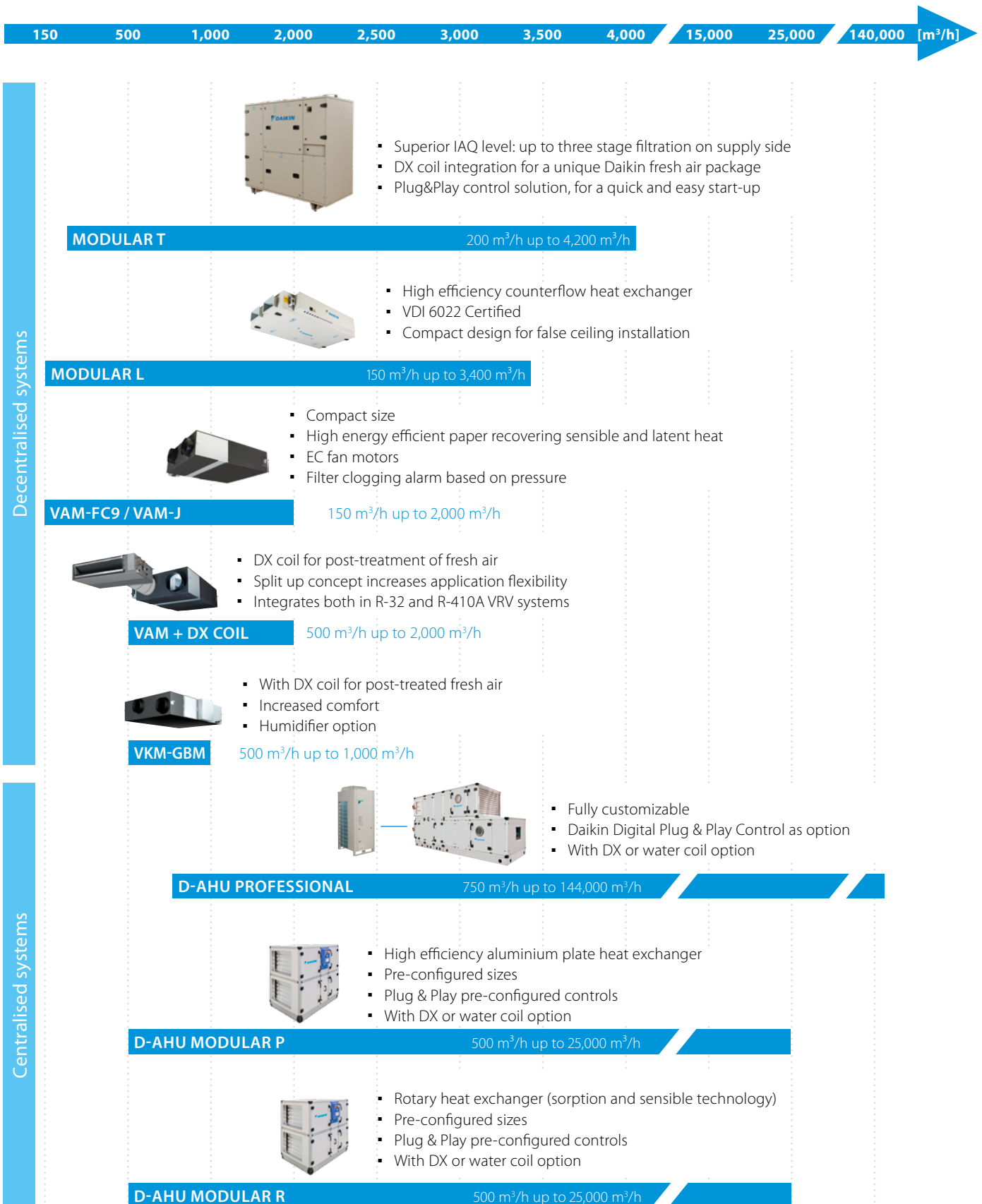

Energy recovery ventilation

Ventilation with heat recovery as standard

- Thinnest High Efficiency Enthalpy Heat Exchanger in the market (J-series)
- Energy saving ventilation using indoor heating, cooling and moisture recovery
- Free cooling possible when outdoor temperature is below indoor temperature (eg. during nighttime)
- Prevent energy losses from over-ventilation while improving indoor air quality with optional CO₂ sensor (J-series)
- Possibility to change ESP via wired remote control allows optimisation of the supply air volume (J - series)
- Can be used as stand alone or integrated in the Sky Air or VRV system
- Wide range of units: air flow rate from 150 up to 2,000 m³/h
- Shorter installation time thanks to easy adjustment of nominal air flow rate, so less need for dampers compared with traditional installation
- No drain piping needed
- Can operate in over- and under pressure
- Total solution for fresh air with Daikin supply of both VAM / VKM and electrical heaters
- VAM-J8 series are connectable to EKVDX DX coil for air processing
- Possibility of visualizing CO₂ concentration when combining VAM-J8 with optional BRYMA CO₂ sensor and Madoka remote controller (with or without EKVDX)

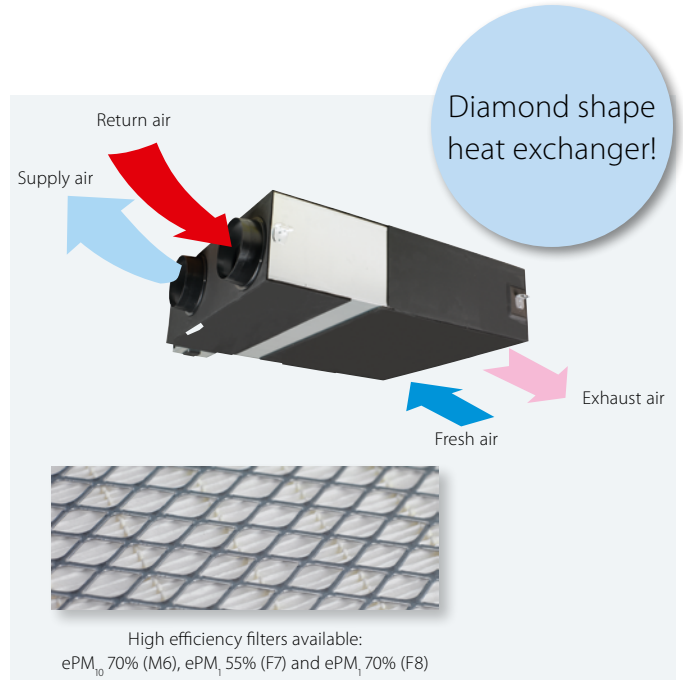

Ventilation		VAM/VAM	150FC9	250FC9	350J8	500J8	650J8	800J8	1000J8	1500J8	2000J8		
Power input - 50Hz	Heat exchange mode	Nom. Ultra high/High/Low	kW	0.132/0.111/0.058	0.161/0.079/0.064	0.097/0.070/0.039	0.164/0.113/0.054	0.247/0.173/0.081	0.303/0.212/0.103	0.416/0.307/0.137	0.548/0.384/0.191	0.833/0.614/0.273	
	Bypass mode	Nom. Ultra high/High/Low	kW	0.132/0.111/0.058	0.161/0.079/0.064	0.085/0.061/0.031	0.148/0.100/0.045	0.195/0.131/0.059	0.289/0.194/0.086	0.417/0.300/0.119	0.525/0.350/0.156	0.835/0.600/0.239	
Temperature exchange efficiency - 50Hz	Ultra high/High/Low		%	77.0(1)/72.0(2)/78.3(1)/72.3(2)/82.8(1)/73.2(2)	74.9(1)/69.5(2)/76.0(1)/70.0(2)/80.1(1)/72.0(2)	85.1/86.7/90.1	80.0/82.5/87.6	84.3/86.4/90.5	82.5/84.2/87.7	79.6/81.8/86.1	83.2/84.8/88.1	79.6/81.8/86.1	
	Cooling	Ultra high/High/Low	%	60.3(1)/61.9(1)/67.3(1)	60.3(1)/61.2(1)/64.5(1)	65.2/67.9/74.6	59.2/61.8/69.5	59.2/63.8/73.1	67.7/70.7/76.8	62.6/66.4/74.0	68.9/71.8/77.5	62.6/66.4/74.0	
Enthalpy exchange efficiency - 50Hz	Heating	Ultra high/High/Low	%	66.6(1)/67.9(1)/72.4(1)	66.6(1)/67.4(1)/70.7(1)	75.5/77.6/82.0	69.0/72.2/78.7	73.1/76.3/82.7	72.8/75.3/80.2	68.6/71.7/77.9	73.8/76.1/80.8	68.6/71.7/77.9	
	Heat exchange mode, bypass mode, fresh-up mode												
Operation mode	Air to air cross flow total heat (sensible + latent heat) exchange												
Heat exchange system	Specially processed non-flammable paper												
Heat exchange element	Galvanised steel plate												
Dimensions	Unit	HeightxWidthxDepth	mm	285x776x525			301x1,113x886		368x1,354x920		731x1,354x1,172		
Weight	Unit		kg	24.0			46.5		61.5		79.0		
Casing	Material	Galvanised steel plate											
Fan	Air flow rate - 50Hz	Heat exchange mode	Ultra high/High/Low	m ³ /h	150/140/105	250/230/155	350(1)/300(1)/200(1)	500(1)/425(1)/275(1)	650(1)/550(1)/350(1)	800(1)/680(1)/440(1)	1,000(1)/850(1)/550(1)	1,500(1)/1,275(1)/825(1)	2,000(1)/1,700(1)/1,100(1)
		Bypass mode	Ultra high/High/Low	m ³ /h	150/140/105	250/230/155	350(1)/300(1)/200(1)	500(1)/425(1)/275(1)	650(1)/550(1)/350(1)	800(1)/680(1)/440(1)	1,000(1)/850(1)/550(1)	1,500(1)/1,275(1)/825(1)	2,000(1)/1,700(1)/1,100(1)
		External static pressure - 50Hz	Ultra high/High/Low	Pa	90/87/40		70/63/25		90(1)/70.0/50.0(1)				
Air filter	Type	Multidirectional fibrous fleeces											
Sound pressure level - 50Hz	Heat exchange mode	Ultra high/High/Low	dBA	27.0/26.0/20.5	28.0/26.0/21.0	34.5(1)/32.0(1)/29.0(1)	37.5(1)/35.0(1)/30.5(1)	39.0(1)/36.0(1)/31.0(1)	39.0(1)/36.0(1)/30.5(1)	42.0(1)/38.5(1)/32.5(1)	42.0(1)/39.0(1)/33.5(1)	45.0(1)/41.5(1)/36.0(1)	
	Bypass mode	Ultra high/High/Low	dBA	27.0/26.5/20.5	28.0/27.0/21.0	34.5(1)/32.0(1)/28.0(1)	38.0(1)/35.0(1)/29.5(1)	38.0(1)/34.5(1)/30.5(1)	40.0(1)/36.5(1)/30.5(1)	42.5(1)/40.0(1)/32.5(1)	42.0(1)/39.0(1)/32.5(1)	45.0(1)/41.0(1)/35.0(1)	
Operation range	Around unit		°CDB	-			0°C~40°CDB, 80% RH or less						
Connection duct diameter			mm	100	150	200	250	2x250					
Power supply	Phase/Frequency/Voltage		Hz/V	1~; 50/60; 220-240/220									
Current	Maximum fuse amps (MFA)		A	15.0			16.0						
Specific energy consumption (SEC)	Cold climate		kWh/(m ² .a)	-56.0(5)	-60.5(5)	-							
	Average climate		kWh/(m ² .a)	-22.1(5)	-27.0(5)	-							
	Warm climate		kWh/(m ² .a)	-0.100(5)	-5.30(5)	-							
SEC class				D / See note 5			B / See note 5						
Maximum flow rate at 100 Pa ESP	Flow rate		m ³ /h	130	207	-							
	Electric power input		W	129	160	-							
Sound power level (Lwa)			dB	40	43	51	54	58	61	62	65		
Annual electricity consumption			kWh/a	18.9(5)	13.6(5)	-							
Annual heating saved	Cold climate		kWh/a	41.0(5)	40.6(5)	-							
	Average climate		kWh/a	80.2(5)	79.4(5)	-							
	Warm climate		kWh/a	18.5(5)	18.4(5)	-							

(1)Measured according to JIS B 8628 | (2)Measured at reference flow rate according to EN13141-7 | (5) At reference flow rate in accordance with commission regulation (EU) No 1254/2014

DX coil for air processing

Post heating or cooling of fresh air to lower the load on the air conditioning system

- Creates a high quality indoor environment by pre conditioning of incoming fresh air
- Maximum installation flexibility thanks to separate DX coil
- Wide range of units covering fresh air flows of 500 up to 2,000 m³/h
- High ESP up to 150 Pa
- Can be integrated in both R-32/R-410A VRV systems

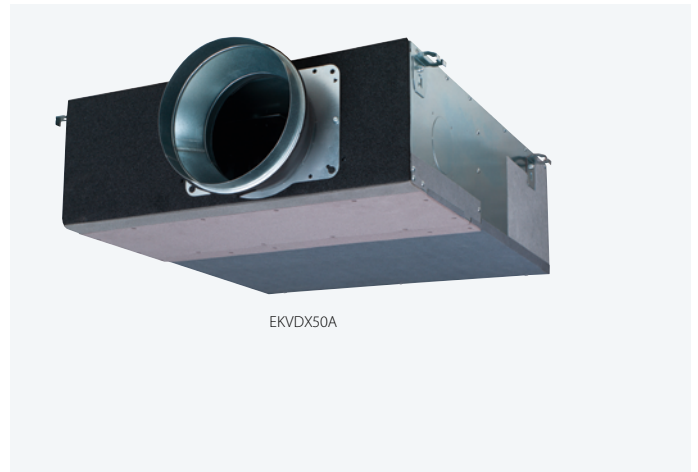

EKVDX50A

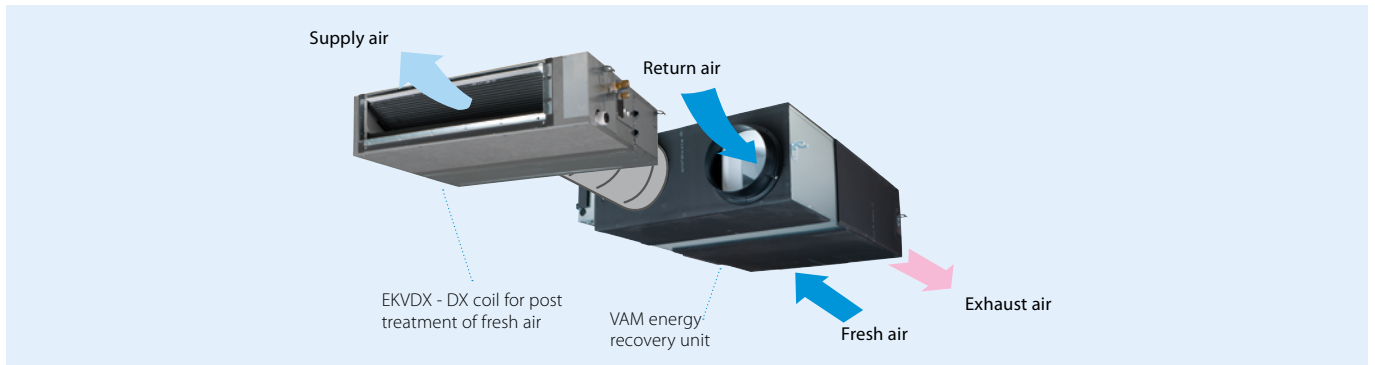

EKVDX-A

				EKVDX32A	EKVDX50A	EKVDX80A	EKVDX100A			
Power input - 50Hz	Cooling	Nom.	kW	0.035	0.035	0.035	0.035			
	Heating	Nom.	kW	0.035	0.035	0.035	0.035			
Casing	Material									
Insulation material	Opcell and anti-sweat material									
Dimensions	Unit	Height	mm	250						
		Width	mm	550	700	1,000	1,400			
		Depth	mm	809						
Weight	Unit	kg		19	23.4	30.1	37.7			
Operation range	Around unit		°CDB	10°C~40°CDB, 80% RH or less						
	On coil temperature	Cooling	Max.	35						
Heating		Min.	11							
Piping connections	Liquid	OD	mm	6.35						
	Gas	OD	mm	12.7						
	Drain	VP20 (I.D. 20/O.D. 26), drain height 625 mm								
Refrigerant	Type	R410A/R32								
	GWP	2,087.5/675								
Heat exchange system	Direct expansion									
Power supply	Phase									
	Frequency			Hz						
	Voltage			V						
Possible Combination VAMJ8 + EKDVX				EKVDX32A + VAM500J8	EKVDX50A + VAM650J8	EKVDX50A + VAM800J8	EKVDX80A + VAM1000J8	EKVDX100A + VAM1500J8	EKVDX100A + VAM2000J8	
Cooling capacity	Total (VAM+DX coil)		At ultra high fan speed	kW	5.1	7.1	8.6	9.3	15.4	18.4
	DX coil		At ultra high fan speed	kW	3.4	4.8	5.5	5.7	9.5	11.2
			At high fan speed	kW	2.7	4.1	4.4	4.5	8.8	9.2
Heating capacity	Total (VAM+DX coil)		At ultra high fan speed	kW	6.7	8.5	11	11.9	18.7	22.9
	DX coil		At ultra high fan speed	kW	4.2	5.1	6.9	7	10.8	13
			At high fan speed	kW	3.6	4.6	5.8	6.3	9.6	11.7
Fan	Air flow rate - 50Hz	Heat exchange mode	Ultra high	m ³ /h	500	650	800	1,000	1,500	2,000
			High	m ³ /h	425	550	680	850	1,275	1,700
	Bypass mode	Ultra high	m ³ /h	500	650	800	1,000	1,500	2,000	
		High	m ³ /h	425	550	680	850	1,275	1,700	
	External static pressure - 50Hz	Maximum	Pa	81.9	73.0	133.7	106.0	153.6	92.1	
		Ultra high	Pa	51.9	43.0	23.7	26.0	43.6	12.1	
Sound pressure level - 50Hz	Cooling	Ultra high	dBA	32	34	35.5	40.5	38.5	43.5	
		High	dBA	30.5	32	34	38	37	40	
	Heating	Ultra high	dBA	32.5	34.5	36	40.5	39	44	
		High	dBA	31.5	32	34	38.5	37	40.5	
	Current	Maximum fuse amps (MFA)		A	6	6	6	6	16	16

The heat reclaim ventilation unit and the EKVDX indoor unit MUST share the same electrical safety devices and power supply

Modular L Smart

Premium efficiency heat recovery unit

Highlights

- Connects Plug&Play into the Sky Air and VRV control network
- Easy installation and commissioning
- Internal pre-filter stage (up to ePM1 50% (F7) + ePM1 80% (F9)) making the unit reach highest indoor air quality requirements.
- Wide air flow coverage from 150m³/h to 3,400m³/h
- Exceeding ErP 2018 requirements
- Best choice when compactness is needed (only 280 mm height up to 550 m³/h)
- 50 mm double skin panel (120 kg/m³) for a maximum sound and thermal insulation

EC centrifugal fan

- Maximum ESP available 600 Pa (depending on model sizes and airflow)
- Inverter driven with IE4 premium efficiency motor
- High-efficient blade profiling
- Reduced energy consumption
- Optimized SFP (Specific Fan Power) for an efficient unit operation

Heat exchanger

- Premium quality counter flow plate heat exchanger
- Up to 91% of the thermal energy recovered
- High grade aluminum allowing optimum corrosion protection



ALB-LBS



ALB-RBS

Technical details

D-AHU Modular L Smart			ALB02*BS	ALB03*BS	ALB04*BS	ALB05*BS	ALB06*BS	ALB07*BS
Airflow	m ³ /h		300	600	1,200	1,600	2,300	3,000
Heat exchanger thermal efficiency (1)	%		86		87			86
External static pressure	Nom. Pa		100					
Current	Nom. A		0.61	1.35	2.26	2.83	4.39	6.22
Power input	Nom. kW		0.14	0.31	0.52	0.65	1.01	1.43
SFPv (2)	kW/m ³ /s		1.25	1.52	1.3	1.35	1.35	1.51
Electrical supply	Phase	ph	1					
	Frequency	Hz	50/60					
	Voltage	V	220/240 Vac					
Main unit dimensions	Width	mm	920	1,100	1,600		2,000	
	Height	mm	280	350	415		500	
	Length	mm	1,660	1,800	2,000			
Rectangular duct flange	Width	mm	250	400	500		700	
	Height	mm	150	200	300		400	
Weight unit	kg		125	180	270	280	355	360

(1) Winter design condition: Outdoor: -5°C, 90% Indoor: 22°C, 50% | (2) SFPv is a parameter that quantifies the fan efficiency (the lower it is the better will be). This reduces if airflow decreases.

Modular T Smart

Top connected Air Handling Unit

Highlights

- Duct connections are located at the top, reducing the unit's footprint
- Low power consumption and low SFP (Specific Fan Power) for a very efficient unit operation
- Superior IAQ level: up to three stage filtration on supply side (more than the 90% of PM1 is removed from outdoor air)
- Plug&Play control solution, for a quick and easy start-up
- Very compact unit, starting from 550 mm width, for an air flow up to 1,100 m³/h
- DX coil integration for a unique Daikin fresh air package available for connection to VRV or ERQ

IAQ matters

An excellent IAQ improves people's performance and well-being, and decreases risk factors for various diseases. Modular T satisfies the ventilation and filtration needs of the indoor environment, guaranteeing an outstanding level of IAQ.

The future of ventilation

The Modular T, with its unique features, represents the latest product developed by Daikin for fresh air treatment and not only. Thanks to its optimized design, it can be easily transported and installed into new projects or existing buildings.



ATB-S



ATB

Technical details

MODULAR T Pro & Smart		Size (1)	03	04	05	06	07
Airflow	m ³ /h		800	1,650	2,300	2,700	3,900
HE Thermal efficiency (2)	%		89.3	88.3	85.1	85.5	90.8
External static pressure	Pa				100		
Current	A		1.70	3.39	4.61	5.17	7.87
Power input	kW		0.39	0.78	1.06	1.19	1.81
SFPv (2)	kW/m ³ /s		1.47	1.5	1.49	1.41	1.5
Electrical supply	Phase (ph)		1				
	Frequency (Hz)		50/60				
	Voltage (V)		220/240 Vac				
Main unit Dimensions	Width (mm)		550		790		890
	Height (3) (mm)		1,600		1,900	1,850	2,050
	Length (mm)		1,580	1,650	2,170 (4)	2,620 (5)	2,950 (5)
Circular duct flange	Diameter (mm)		255	315	355	400	500
Unit sound power level	dB(A)		57	52		55	58
Unit sound pressure level (6)	dB(A)		50	45		48	51
Weight unit	Kg		200	250	400	500	620

(1) All size available in Smart or Pro version and right or left handing | (2) Outdoor condition: -5°C, 90% Indoor condition: 25°C, 50% | (3) Including feet and duct connections | (4) Size 05 is provided in two sections | (5) Size 06 and 07 are provided in three sections | (6) Simple source reference value at 1 meter, directivity factor Q=4 (quarter sphere) and non-reverberant field. Allowances on declared values: +/- 3dB

Combining Air Handling Units with DX outdoor units



High comfort levels

- Rapid response of supply air temperature to changing loads, results in a steady indoor temperature
- VRV offers the ultimate comfort thanks to continuous heating, also during defrost

Low carbon footprint and operating costs

- DX heat pumps are highly efficient inverter units using a lower GWP refrigerant
- By integrating a VRV heat recovery system, excess heat from rooms in cooling can be reused to heat up incoming fresh air

Easy design, all components integrated

- A DX system is an all-in-one system, no boilers, tanks or pumps are needed reducing the total investment cost

One-stop shop, Daikin's fresh air package

- A plug & play package with a Daikin DX outdoor unit and Daikin Air Handling Unit
- One point of contact for the design, installation and commissioning, streamlining the process

Total solution operation example

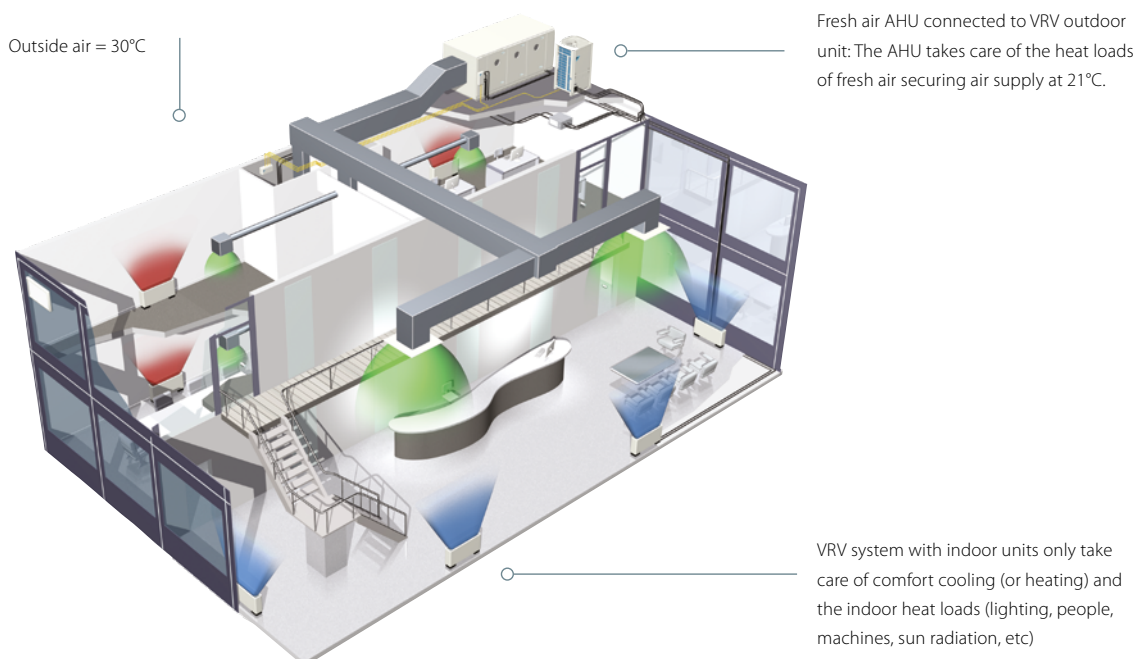

Daikin Air Handling Unit kits for connection to DX outdoor units

R-32

Expansion valve kits **NEW**

- 3 new capacities (300,350,400) offer a complete range of expansion valve kits from 5 to 69.3kW
- Improved flexibility thanks to combination ratio from 65% up to 110%
- Unified range connectable both to R-32 and R-410A systems
- Can be used in the most extreme outdoor conditions, down to -20°C
- Fully compliant to IEC60335-2-40, thanks to Shirudo Technology

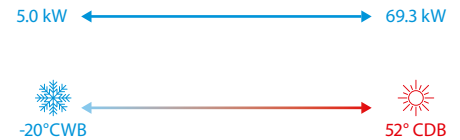

Control box **NEW**

- Complete offer of 5 control possibilities
 - Daikin integrated or third-party controller
 - Control of return air or fresh air supply temperature
- All control methods unified in one box
- Hinged door for easy servicing



Expansion valve set (EKEXVA*)

- Controls the refrigerant flow in the AHU DX coil
- Fully brazed and wired in case of a Daikin AHU

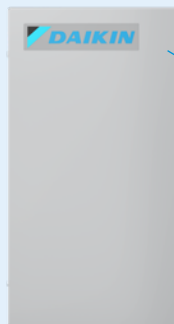

Control box (EKEACB)

- Controls the expansion valve set and outdoor unit(s) capacity
- Mounted and wired in case of a Daikin AHU



Specifications

EKEXVA – Expansion valve kit

Ventilation		EKEXVA	50	63	80	100	120	140	200	250	300	350	400	450	500	
Dimensions	Unit	mm	404x217x80.5													
Weight	Unit	kg	2.9													
Operation range	On coil	Heating Min. °CDB	10.0													
	temperature	Cooling Max. °CDB	35.0													
Ambient installation conditions	Min.	°CDB	-20.0													
	Max	°CDB	52.0													
Sound pressure level	Cooling	Nom. dBA	36.5	37.5	38.6	39.5	40.5	41.1	42.5	43.5	44.3	45.1	45.6	46.1	46.5	
	Nom.	dBA	24.8	25.8	26.8	27.8	28.8	29.4	30.8	31.8	32.5	33.3	33.8	34.3	34.8	
Refrigerant	Type / GWP		R-32 / 675						R-410A / 2,087.5							
Piping connections	Liquid	Type	Brazed connection (only liquid line connected)													
	OD	mm	6.35			9.52						12.7				

EKEACB – Control box

			EKEACB		
Layout			Pair Multi Mix		
Dimensions	Unit	mm	300x400x150		
Weight	Unit	kg	5.1		
Ambient installation conditions	Min	°CDB	-20		
	Max	°CDB	52		
Power supply	Phase		1~		
	Frequency	Hz	50/60		
	Voltage	V	220-240/220		

Click more information on [EKEACB](#) or [EKEXVA](#) outdoor units

Air Handling Unit kits – Layout possibilities

With our wide capacity range and different control options, a variety of layout possibilities to match your application:

- **Pair layout:** one or more outdoor units combined with 1 air handling unit
- **Multi layout:** one outdoor unit combined with multiple air handling units
- **Mix layout:** one outdoor unit combined with an air handling unit AND indoor units

Pair layout

One ERQ or VRV heat pump (system) connected to one AHU through one refrigerant circuit

- with W, X, Y, Z, Z' control
- not allowed for VRV H/R



One VRV heat pump (system) connected to the interlaced coil of one AHU through several refrigerant circuits

- with W, X, Y control
- not allowed for VRV H/R and VRV-i

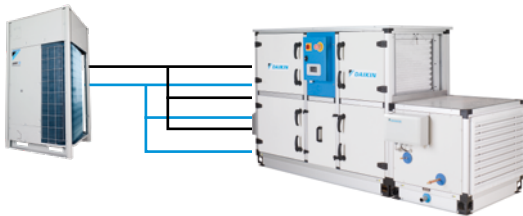

Several ERQ or VRV heat pumps connected to the interlaced coil of one AHU through several refrigerant circuits

- with W, X, Y control
- not allowed for VRV H/R and VRV-i

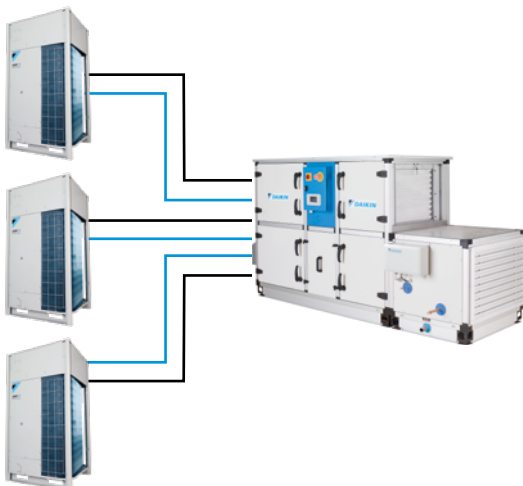

Multi layout

One VRV heat pump connected to s

- with Z, Z' control and field supplied controls on AHU side.
- not allowed for VRV H/R
- no interlaced coil possible

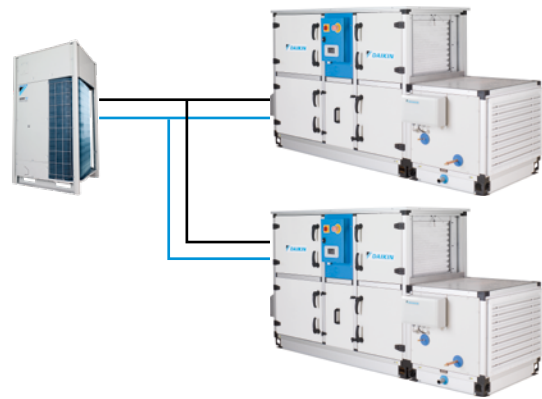

Mix layout

VRV indoor units and AHU(s) mixed in the same VRV heat pump or heat recovery system

- with Z, Z' control and field supplied controls on AHU side
- no interlaced coil possible
- hydrobox not possible

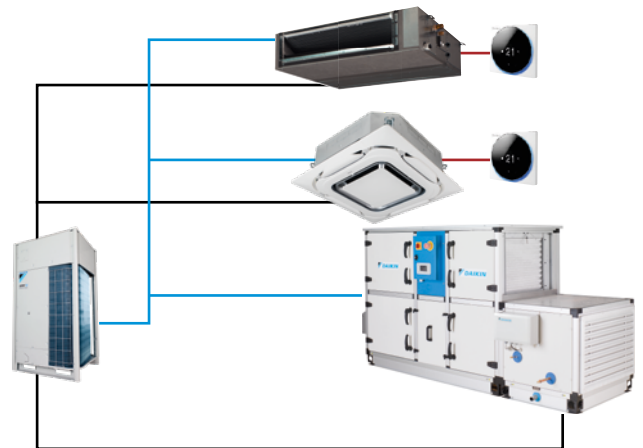

- Refrigerant piping
- F1-F2
- P1-P2



Daikin Fresh Air package

What is included?

- A plug & play package with a Daikin DX outdoor unit and Daikin Air Handling Unit
- Factory fitted and welded DX coil, expansion valve kit and control box
- One point of contact



VRV or ERQ outdoor condensing unit



Daikin Air Handling Unit



Factory fitted and welded DX coil, expansion valve kit and control box

Simplified business

- Unique total solution approach of heating, cooling and ventilation
- Off-the-shelf compatibility between Daikin outdoor unit and Daikin AHU
- Plug&play control for outstanding reliability
- **Peace-of-mind thanks to a single point of contact**

Simple selection in 2-steps

STEP 1



Select your design in ASTRA software

STEP 2

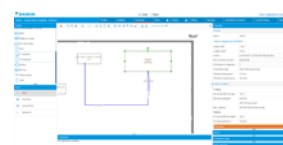

Add the AHU design in Xpress (including capacity, dimensions, refrigerant connection location,...)

Complete range of possibilities



750 m³/h up to 144,000 m³/h

D-AHU Professional

- Infinite variable sizes
- Tailored to the individual customer



500 m³/h up to 25,000 m³/h

D-AHU Modular R

- Pre-configured sizes
- Plug and play concept
- EC Fan technology
- Heat recovery wheel (sorption and sensible technology)
- Compact design



500 m³/h up to 25,000 m³/h

D-AHU Modular P

- Pre-configured sizes
- Plug and play concept
- EC Fan technology
- High efficiency aluminium counter flow PHE
- Compact design

Astropure 2000, Air Purifier for Commercial Applications



Plug & play, mobile recirculation unit with high efficiency filtration – for better indoor air quality in commercial spaces

- For areas where additional, extra high, filtration performance is needed.
- Airflow rate up to 2,000 m³/h
- HEPA H14 filter in accordance with EN1822
- Pre-filter options up to ISO Coarse 70%
- Insulated double-wall construction provides whisper-quiet operation down to 35 dB(A)
- Easy installation, operation, and maintenance in a totally self-contained system
- For commercial areas up to 200m²



Models

Model	BR00000554	BR00000749	BR00000676	BR00000751
Plug type	EU	UK	EU	UK
HEPA Filter (H14)		✓		✓
LCD Screen			✓	✓
Activ. Carbon (Gas phase) pre-filter			✓	✓

Applications



Schools and Universities



Commercial Buildings



Healthcare



Hospitality



Shops and Shopping malls

Providing high-efficiency 2-stage filtration

Standard prefilter

All units are delivered with a prefilter, increasing filter life and protecting the installed HEPA filter

RedPleat - 4531002424

- Delivered with BR00000554/749
- ISO 16890: ISO coarse 70%
- Available with Antimicrobial treated media (RedPleat ULTRA)



RedPleat Carb - 4139002424

- Delivered with BR00000676/751
- ISO 16890: ISO coarse 65%
- Effectively removes offensive odors



Main filter

The HEPA filter features eFRM filtration media which combines ultra-high efficiency and particulate loading to remove 99.99% of dust, pollen, mold, bacteria, viruses, and any airborne particle with a size of 0.3 microns or greater.

AstroCel III - 1493299990

- H14 filtration efficiency according EN 1822
- V-shaped filter configuration, combined with microglass media, delivers higher flow and the lowest possible pressure drop vs traditional box style HEPA filters
- Compatible with Discrete Particle Counter (DPC) and photometric test methods as access and instrumentation allow



Astropure 2000, Air Purifier for Commercial Applications

Plug & play, mobile recirculation unit with high efficiency filtration – for better indoor air quality in commercial spaces

- Airflow rate up to 2,000 m³/h
- HEPA H14 filter in accordance with EN1822
- Optional touch sensitive LCD Display (BR00000676/751)
- Insulated double-wall construction provides whisper-quiet operation
- Activated carbon filter
- Sliding tray design provides easy access and servicing of filters
- Designed with internal variable fan speed (electronically commutated) to meet specific application requirements
- Suitable for in-room use or sheltered outdoor installation
- CE-compliance, VDI 6022 guided design



BR00000554





BR00000676

Ventilation				BR00000554	BR00000749	BR00000676	BR00000751
Features	Plug type			EU	UK	EU	UK
	HEPA Filter (H14)				✓		✓
	LCD Screen						✓
	Activ. Carbon (Gas phase) pre-filter						✓
Design air flow rate	m ³ /h			2,000			
Application				Floor standing type			
Casing	Colour			Painted galvanized steel finish			
Dimensions	Unit	HxWxD	mm	1,628x720x770			
Weight	Unit		kg	150 (depending on version)			
Pre-filter	Dust collecting method			Prefilter RedPleat, ISO Coarse 70%		Prefilter RedPleat Carb, ISO Coarse 65% gas phase filter	
HEPA filter	Bacteria filtering method			Astrocel III HEPA H14			
Air purifying operation	Power input	High fan speed	kW	0.379			
Sound pressure level	Air purifying operation	High fan speed	dB(A)	55.9			
Fan Motor				Stepless adjustable			
Safety devices	Item			Safety switch (operation stops when the back door is open)			
Standard Accessories	Prefilter			1			
	HEPA filter			1			
	Quick Start and Maintenance Guide			1			
	Installation and Operation Manual			1 (download)			
Power cord			m	3			
Power supply	Phase			1~			
	Frequency		Hz	50/60			
	Voltage		V	230			
Running current	Air purifying operation	High fan speed	A	1.73			



Control systems

Controls solution summary	108
▪ Applications overview	108
Individual control systems	110
▪ Onecta App	110
▪ Madoka wired remote controller	112
▪ Wired / infrared remote controllers	115
▪ Multi-zone controller	116
Centralised control systems	118
▪ Intelligent tablet controller 	118
▪ Intelligent touch manager 	120
▪ Daikin Cloud Plus 	124
	NEW
Standard protocol interfaces	132
▪ Individual Modbus Interface	NEW 132
▪ DIII-net modbus Interface	134
▪ KNX Interface	135
Other devices	136
▪ Wireless room temperature sensor	136
▪ Wired room temperature sensor	136
▪ Adapter PCB's	137

Connect with Daikin

If you are a user or installer it is important you can **interact with our systems** in the easiest way, from **anywhere you are**. For any user our interfaces create **peace of mind** that their system is running in the best possible way.

Depending on the type of user and application Daikin develops controls and cloud services to ensure the best experience.

- For home owners it means **app and voice control** of their home comfort.
- For hotel owners it means easy and stylish **personal control for guests**, with an integration in hotel booking software for central control
- For facility managers it means **cloud access** to all sites, with the possibility to benchmark, optimize performance
- For installers it means **easy transfer of settings during commissioning**, remote retrieval of errors and preventive alerts to save time on maintenance or interventions

Our controls enable you to **connect with your customer**, save time, improve your comfort intelligently and reduce energy bills.



White



Silver



Black

Remote monitoring

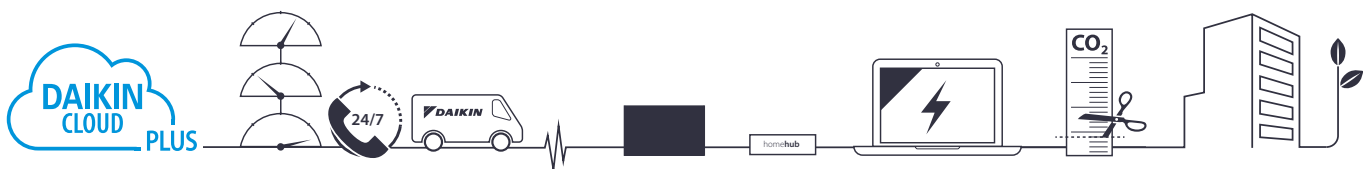
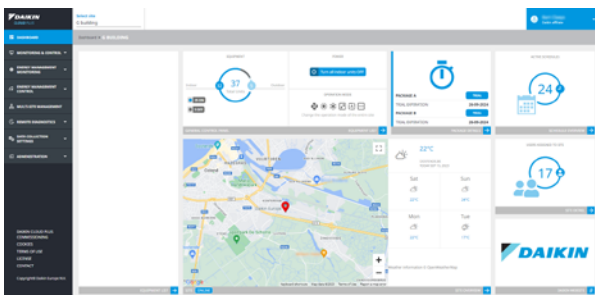



Applications overview

Daikin offers various control solutions adapted to the requirements of even the most demanding commercial application.

- Basic control solutions for those customers with few requirements and limited budget
- Integrating control solutions for those customers who would like to integrate Daikin units into their existing BMS system
- Advanced control solutions for those customers who expect Daikin to deliver a mini BMS solution, including advanced energy management

Infrastructure cooling









	Unit	Integrating control	Advanced
			
	BRC1H52W/S/K	RTD-10	DCM601B51
	1 remote controller for 1 indoor unit (group) (2)	1 gateway for 1 indoor unit (group) Up to 8 gateways can be linked together	1 iTM for 64 indoor unit(s) (groups) (1)
Automatic control of A/C	●	●	●
Back-up operation	●	●	●
Duty rotation	●	●	●
Limit control possibilities in the technical cooling room	●	●	●
If room temperature above max., then show alarm & start standby unit.		●	●
If an error occurs, an alarm will be shown.	●	●	●
If an error occurs, activate an alarm output	Via KRP2/4A option (3)	●	Via WAGO I/O

(1) 7 plus adapters (DGE601A52 and DGE601A53) can be added to have 512 indoor groups and 56 outdoor (systems) | (2) Infrastructure cooling functions only compatible with indoor units connected to RZQG*/RZAG* outdoor units. | (3) See option list of indoor unit

Hotel









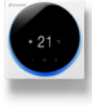

	Unit control	Integrating control		Advanced control		
						
	BRC1H52W/S/K	RTD-20	KLIC DI V2	DCM010A51	DCM601B51	DGE601A51 DGE602A51
	1 remote controller for 1 indoor unit (group)	1 gateway for 1 indoor unit (group) Up to 16 gateways can be linked together	Two additional probes can be connected	1 interface for up to 2,500 indoor units (3)	Up to 512 indoor unit(s) (groups) (1)	Up to 512 units with extension modules via Daikin Cloud Plus (1) Max 64 units via Daikin Cloud Plus
Hotel guest can control & monitor basic functionalities from his room	●					
Limit control possibilities for hotel guests	●	●	●	●	●	●
Interlock with window contact	●(2)	●			●	●
Interlock with key-card	●(2)	●			●	●
Integrate Daikin units into existing BMS via Modbus		●				
Integrate Daikin units into existing BMS via KNX			●			
Integrate Daikin units into existing BMS via HTTP				●		
Integrate Daikin unit control in hotel booking software				●		
Oracle Opera PMS				●		
Monitor energy consumption					●	●
Advanced energy management					●	●
Integrate Daikin products cross pillars into Daikin BMS					●	
Integrate third party products into Daikin BMS					●(4)	●
Online control					●	●

(1) 7 plus adapters (DGE601A52 and DGE601A53) can be added to have 512 indoor groups and 56 outdoor (systems) | (2) Interlock with window and key-card is possible with options BRP7A51/52/53/54 | (3) When 5 iTM's are connected | (4) Via http with the option DCM007A51

Office









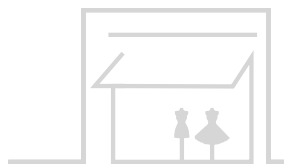



	Unit control	Integrating control			Advanced control			
								
	BRC1H52 W/S/K	EKMBDXB	DMS504B51	DMS502A51	DCC601A51	DCM601B51	DGE601A51	DGE602A51
	1 remote controller for 1 indoor unit (group)	1 gateway for max. 64 indoor unit(s) (groups) & 10 outdoors	1 gateway for 64 indoor unit(s) (groups)	1 gateway for 128 indoor unit(s) (groups), 20 outdoors (2)	1 unit for 32 indoor unit(s) (groups)	Up to 512 indoor unit(s) (groups) (1)	Up to 512 units with extension modules via Daikin Cloud Plus (1)	Max 64 units via Daikin Cloud Plus
Automatic control of A/C	●	●	●	●	●	●	●	●
Centralised control for management		●	●	●	●	●	●	●
Local control for office staff	●				●	● Through web	●	●
Limit control possibilities for office staff	●	●	●	●	●	●	●	●
Integrate Daikin units into existing BMS via Modbus		●						
Integrate Daikin units into existing BMS via HTTP						● (6)		
Integrate Daikin units into existing BMS via LonTalk			●					
Integrate Daikin units into existing BMS via BACnet				●				
Energy consumption read out	● (3)					●	●	●
Monitor energy consumption						●	●	●
Advanced energy management						● (5)	●	●
PPD software to distribute used kWh/indoor unit				● (4)		●	●	●
Integrate Daikin cross pillar products into Daikin BMS		●				●		
Integrate third party products into Daikin BMS						●	●	●
Online control							●	●
Manage multiple sites							●	●

(1) 7 plus adapters (DGE601A52 and DGE601A53) can be added to have 512 indoor groups and 56 outdoor (systems) | (2) Extension (DAM411B51) needed to have up to 256 indoor unit(s) (groups), 40 outdoors | (3) Not available on all indoor units | (4) via DAM412B51 option | (5) via DCM002A51 option | (6) Via http with the option DCM007A51

Shop



	Unit control	Integrating control			Advanced control					
										
	BRP069*	BRC1H52 W/S/K	RTD-20	EKMBPP1	KLIC DI V2	EKMBDXB	DCC601A51	DCM601B51	DGE601A51	DGE602A51
	Smartphone control for up to 50 indoor units	1 remote controller for 1 indoor unit (group)	1 gateway for 1 indoor unit (group) Up to 16 gateways can be linked together	1 gateway for 1 indoor unit (group)	Two additional probes can be connected	1 gateway for max. 64 indoor unit(s) (groups) & 10 outdoors	1 unit for 32 indoor unit(s)	1 iTM for 64 indoor unit(s) (groups) (1)	Up to 512 units with extension modules via Daikin Cloud Plus	Max 64 units via Daikin Cloud Plus
Automatic control of A/C	●	●	●	●	●	●	●	●	●	●
Limit control possibilities for shop staff	●	●	●	●	●	●	●	●	●	●
Create zones within the shop			●				●	●	●	●
Interlock with eg. Alarm, PIR sensor			●				● (limited)	●	●	●
Integration into smart home systems	● (5)									
Integrate Daikin units into existing BMS via Modbus			●	●		●				
Integrate Daikin units into existing BMS via KNX					●					
Integrate Daikin units into existing BMS via HTTP								●		
Monitor energy consumption	● (3)	● (3)						●	●	●
Advanced energy management								●	●	●
Allows free cooling								●		
Voice control	● (4)									
Integrate Daikin products cross pillars into Daikin BMS						●		●		
Integrate third party products into Daikin BMS								●	●	●
Online control	●							● (2)	●	●
Manage multiple sites									●	●

(1) 7 iTM plus adapters (DGE601A52 and DGE601A53) can be added to have 512 indoor groups and 80 outdoor (systems) | (2) Through own IT set-up (not Daikin cloud server) | (3) Not available on all indoors | (4) Only for BRP069C51, connection to Google Assistant and Amazon Alexa | (5) Only for BRP069C51, contact your local sales representative for an overview of available services.



Onecta App

Now available with voice control

The Onecta App is for those who live their life on the go and who want to manage their Daikin system from their smartphone.



onecta Voice control

To provide users with even more comfort and ease, the Onecta App now offers voice control. This hands-free feature cuts down on clicks to manage units faster than ever before.

Cross-functional and multilingual, voice control pairs well with any smart device, including Google Assistant and Amazon Alexa.

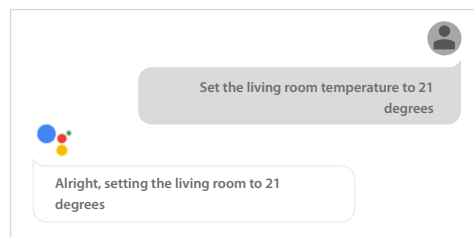

Example of using the voice control via Google Assistant

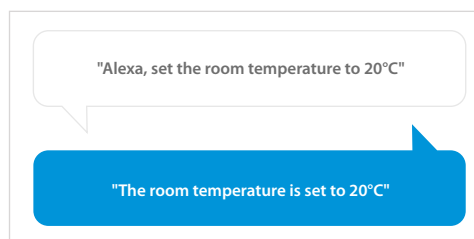

Scan the QR code to download the app now:





Schedule

Set up a programme outlining when the system should operate, and create up to six actions per day.

- Schedule room temperature and operation mode
- Enable holiday mode to save costs



Monitor

Receive a thorough overview of how the system is performing and how much energy it consumes.

- Check the status of the heating system
- Access energy consumption graphs (day, week, month)

NEW
Energy
consumption
graphs for
Sky Air!

Function availability depends on the system type, configuration and operation mode. The app functionality is only available if both the Daikin system and the app have a reliable internet connection.

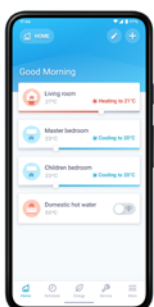

Control

Customise the system to fit your lifestyle and year-round comfort levels.

- Change room temperature
- Turn on powerful mode

For VRV

	Model #	WLAN
VRV 5 indoor units	FXFA-A	Optional: BRP069C51 (1)
	FXZA-A	
	FXKA-A	
	FXDA-A	
	FXSA-A	
	FXMA-A	
	FXHA-A	
	FXUA-A	
	FXAA-A	

(1) Must be combined with BRC1H52W/S/K

For Sky Air

	Model #	WLAN	
Sky Air	FDXM-F9	Optional BRP069C81 (1)	
	FFA-A9		
	FBA-A(9)		
	FDA125A		
	ADEA-A		
	FAA-B		
	FHA-A(9)		
	FUA-A		
	FVA-A		
	FNA-A9		
	FCAG-B		Optional BRP069C82 (2)
	FCAHG-H		
	FDA200-250A		Optional BRP069C82 (3)

(1) Only possible in combination with wired or wireless remote control | (2) EWHARI is required if autocleaning panel & Onecta is connected.; Cannot be combined with KRP4A53; Only possible in combination with wired or wireless remote control | (3) Cannot be combined with KRP4A51 and KRP2A51

Madoka wired remote controller

The beauty of simplicity.

Madoka



White
RAL9003 (glossy)
BRC1H52W



Silver
RAL 9006 (metallic)
BRC1H52S



Black
RAL 9005 (matte)
BRC1H52K

User-friendly wired remote controller with premium design

Madoka combines refinement and simplicity

- Sleek and elegant design
- Intuitive touch-button control
- Three display options: standard, detailed and **new symbolic view**
- Three colours to match any interior
- Compact, measures only 85 x 85 mm
- Advanced settings **copy function** and commissioning via smartphone
- CO₂ concentration visualisation



reddot award 2018
winner





Madoka Assistant

Simplifies the advanced settings such as schedule or set point limitation

- Visual interface simplifies advanced settings such as schedule setting, energy saving activation, setting restrictions, etc.
- Save field settings and schedules on your phone and upload to multiple controllers, saving time and cost
- Easy and quick commissioning
- Featuring Bluetooth® low energy technology

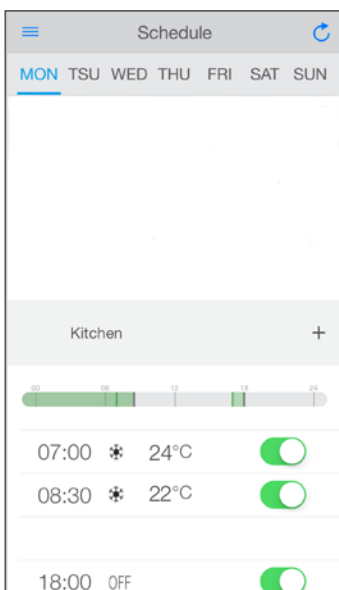

Easy setting of schedules

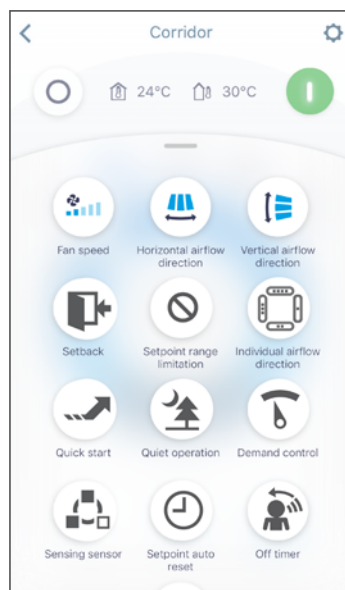

Advanced user settings

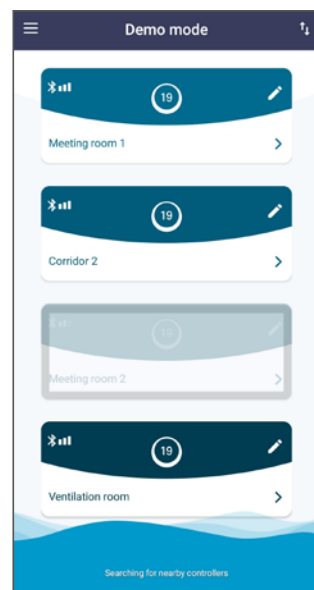

Bluetooth strength indication

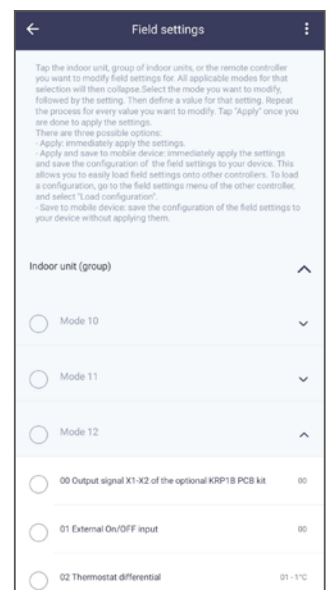

Field settings

Madoka wired remote controller for Sky Air and VRV

Benefits

- Sleek and elegant design
- Intuitive touch-button control
- Three display options: standard, detailed and **symbolic view**
- Direct access to basic functions (on/off, set point, mode, target values, fan speed, louvres, filter icon & reset, error & code)
- Three colours to match any interior
- Compact, measures only 85 x 85 mm
- Real time clock with auto update to daylight saving time

Hotel application features

- Energy saving through key card, window contact integration and set point limitation (BRP7A*)
- Flexible setback function ensures room temperature remains within comfortable limits to ensure guest comfort

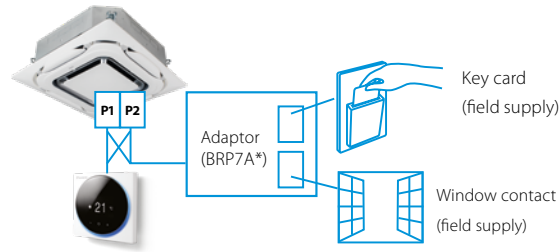

BRC1H52W
Symbolic view



BRC1H52S
Standard view



BRC1H52K
CO₂ visualisation

Madoka assistant benefits



A range of energy-saving functions that can be selected individually

- Temperature range restriction: Save on energy by setting the low temperature limit in cooling mode and the high temperature limit in heating mode (1)
- Setback function
- Adjustable presence detector and floor sensor (available on the Round Flow and Fully Flat Cassettes)
- Automatic temperature reset
- Auto off timer

Kilowatt-hour consumption tracking (2)

The kWh indicator displays indicative power consumption for the last day/month/year.

Other functions

- Three user access levels: Basic user, Advanced and Installer to match user requirements and prevent improper use.
- Save field settings and schedules on your phone and upload to multiple controllers, saving time and cost
- Mark frequently used menu's as favourites for direct access
- Up to three independent schedules can be programmed, allowing you to switch easily between them throughout the year (e.g. summer/winter/mid-season)
- Menu settings can be individually locked or restricted
- The outdoor unit can be set to quiet mode and power consumption limit control by schedule (3)
- Real-time clock that updates automatically for daylight saving



Cost-effective solution for infrastructure cooling applications

- Only in combination with RZAG* / RZQG*
- Duty rotation

After a certain period of time, the operating unit will go into standby and the standby unit will take over, extending the system lifetime. Rotation interval can be set for 6, 12, 24, 72 or 96 hours, as well as weekly.

- Back-up operation: if one unit fails, the other unit will start automatically

- (1) Also available in auto cooling/heating changeover mode
- (2) For Sky Air FBA, FCAG and FCAHG pair combinations only
- (3) Only available on RZAG*, RZASG*, RZQG*, RZQSG*

Functions overview

Basic	Max. Number of IU/Groups	16	Advanced	Temperature setback control	✓
	On / Off	✓		Filter Sign/Reset	✓
	Fan Speed Control	✓		Refrigerant Leakage Detection	✓
	Temperature Setting	✓		Energy Monitoring	✓
	Mode	Cool / Heat / Dry / Fan / Auto / Ventilation		Dual Set Point	✓
	Auto Swing	✓		Human Detection	✓
	Vane Control (Louver direction)	✓		Humidity Compensation	✓
	Electric Failure Compensation (Backup operation)	✓		Air Quality Level**	✓
	Duty Rotation	✓		Defrost Operation	✓
	Indoor Temperature Display	✓		Bluetooth assistant mobile app	✓
	Lock functionality*	✓	ETC	3rd Party Interlocking	✓
	Schedule (Timer)*	Weekly - Yearly		Error Display	✓
				Operation Status	✓
				Display	Monochrome

* With assistant app

** CO₂ level with Bryma sensor

BRC1E53A

User friendly remote control for Sky Air and VRV



Graphical display of indicative electricity consumption (Function available in combination with FBA-A, FCAG and FCAHG)

A series of energy saving functions that can be individually selected

- Demand control (1)
- Temperature range limit
- Setback function
- Presence & floor sensor connection (available on round flow and fully flat cassette)
- kWh indication (2)
- Set temperature auto reset
- Off timer

Other functions

- Up to 3 independent schedules
- Possibility to individually restrict menu functions
- Choice of display between symbol or text
- Real time clock with auto update to daylight saving time
- Built-in backup power for clock (up to 48 hours). Settings are always kept in case of power loss.
- Supports multiple languages:
BRC1E53A: English, German, French, Dutch, Spanish, Italian, Portuguese



Cost-effective solution for infrastructure cooling applications

- Only in combination with RZAG* / RZQG*

(1) Only available on RZAG*, RZASG*, RZQG*, RZQSG* (2) For Sky Air FBA, FCAG and FCAHG pair combinations only

BRC1D52

Wired remote control for Sky Air and VRV



BRC1D52

- Schedule timer: Five day actions can be set
- Home leave (frost protection): during absence, the indoor temperature can be maintained at a certain level. This function can also switch the unit ON/OFF
- User friendly HRV function, thanks to the introduction of a button for ventilation mode and fan speed
- Immediate display of fault location and condition
- Reduction of maintenance time and costs

BRC4*/BRC7*

Infrared remote control



BRC4*/BRC7*

Operation buttons: ON / OFF, timer mode start / stop, timer mode on / off, programme time, temperature setting, air flow direction (1), operating mode, fan speed control, filter sign reset (2), inspection (2)/ test indication (2)

Display: Operating mode, battery change, set temperature, air flow direction (1), programmed time, fan speed, inspection / test operation (2)

(1) Not applicable for FXDQ, FXSQ, FXNQ, FBDQ, FDXM, FBA

(2) For FX** units only

(3) For all features of the remote control, refer to the operation manual

Multi-zone controller

The multi-zoning system is a room-by-room controller. It is fitted with motorised dampers, which immediately adapt using Daikin ducted solutions. This system supports control of up to 8 zones connected to one indoor unit via a centralised thermostat located in the main room and individual thermostats for each of the zones.

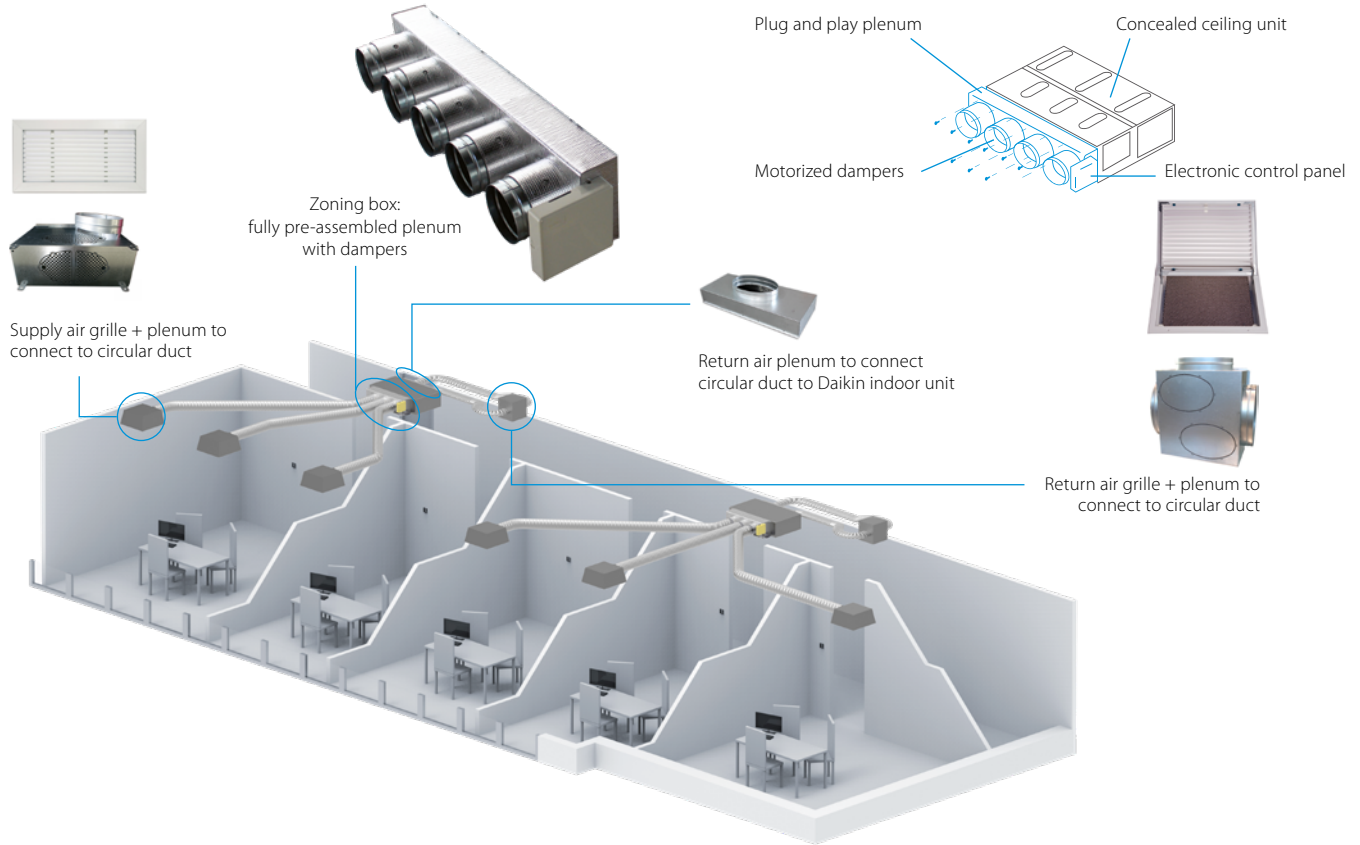

Compatibility

				<i>SkyAir</i>										<i>VRV IV⁺</i>																										
				FDXM-F9				FBA-A(9)				ADEA-A		FXDQ-A3					FXSQ-A																					
Number of motorised dampers	Reference	Dimensions H x W x D (mm)	Ø (mm)	25	35	50	60	35	50	60	71	100	125	140	71	100	125	15	20	25	32	40	50	63	15	20	25	32	40	50	63	80	100	125	140					
Standard plenum	2	AZE(Z/R)6DAIST07XS2 AZE(Z/R)6DAIST07S2	300 x 930 x 454																																					
	3	AZE(Z/R)6DAIST07XS3 AZE(Z/R)6DAIST07S3																																						
	4	AZE(Z/R)6DAIST07M4 AZE(Z/R)6DAIST07M5 AZE(Z/R)6DAIST07L5		300 x 1,140 x 454																																				
	5	AZE(Z/R)6DAIST07M6 AZE(Z/R)6DAIST07L6		300 x 1,425 x 454																																				
	6	AZE(Z/R)6DAIST07L7 AZE(Z/R)6DAIST07XL7 AZE(Z/R)6DAIST07L8 AZE(Z/R)6DAIST07XL8	300 x 1,638 x 454	200																																				
	7	AZE(Z/R)6DAIST07L7 AZE(Z/R)6DAIST07XL7	515 x 1,425 x 454																																					
	8	AZE(Z/R)6DAIST07L8 AZE(Z/R)6DAIST07XL8	515 x 1,425 x 454																																					
	2	AZEZ6DAIBS07XS2 AZEZ6DAIBS07S2	250 x 930 x 454																																					
	3	AZEZ6DAIBS07S3 AZEZ6DAIBS07M3 AZEZ6DAIBS07S4																																						
	4	AZEZ6DAIBS07M4 AZEZ6DAIBS07L4 AZEZ6DAIBS07S5 AZEZ6DAIBS07M5 AZEZ6DAIBS07L5 AZEZ6DAIBS07XL5			250 x 1,140 x 454																																			
5	AZEZ6DAIBS07M6 AZEZ6DAIBS07L6 AZEZ6DAIBS07XL6	250 x 1,425 x 454																																						
6	AZEZ6DAIBS07L6 AZEZ6DAIBS07XL6	250 x 1,638 x 454																																						
Slim plenum	2	AZE(Z/R)6DAISL01S2 AZE(Z/R)6DAISL01S3	210 x 720 x 444																																					
	3	AZE(Z/R)6DAISL01M4 AZE(Z/R)6DAISL01M5		210 x 930 x 444																																				
	4	AZE(Z/R)6DAISL01M4 AZE(Z/R)6DAISL01L5	210 x 1,140 x 444																																					
	5	AZE(Z/R)6DAISL01L5	210 x 1,140 x 444																																					

(1) Z models are reversible; R models are heating only
 (2) Medium Ceiling Void reversible units can be blocked to heating only via AZX6MCS module

Controls

3 controller versions are available to choose from: Colour, touch or simplified



AZCE6BLUEZERO CB (Wired)

Bluezero - main thermostat

- Intuitive graphical, colour touch screen for controlling multiple zones



AZCE6THINKRB (Wireless)

Think - zone thermostat

- Graphic touch button with low-energy e-ink screen for controlling single zones



AZCE6LITE CB (Wired)
AZCE6LITE RB (Wireless)

Lite - zone thermostat

- Simplified thermostat with touch buttons for temperature control

- Optional bus cable (2 x 0.5 mm² | 2 x 0.22 mm²), 15 m length: AZX6CABLEBUS15, 100m length: AZX6CABLEBUS100



AZX6WSPHUB

Webserver for remote control

- Cloud based remote control of multizoning kit(s)
- Configuration and control of zones (temperature, operation mode, ...)
- Access via webportal, or Android/iOS application
- Supports Ethernet and WIFI
- AZX6WSPHUB:
 - For installation on DIN rail
 - 32 zoning boxes can be controlled
- AZX6WSC5GER:
 - For installation in the unit
 - Controls one zoning box



AZX6WSC5GER



AZX6WSPBAC

BACnet or KNX gateway

- Allows ON/OFF control of each zone
- Control of temperature for each zone
- Status indication of operation mode
- One gateway needed per system



AZX6KNXGTWAY

Grilles and plenums

Supply air grilles and plenums



RDHV040015BKX

Wall type supply grille

- With horizontal and vertical adjustable flaps



RLQV040015BKX

Ceiling type supply grille

- With horizontal flaps angled at 15°
- Vertical flaps can be adjusted manually

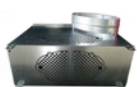

PREJ0400150T

Plenum for supply grille

- To connect circular ducts to discharge grille
- Insulated, galvanised steel
- Diameter 250mm

Return air grilles and plenums



RRFR050050BTX

Return air grille with integrated filter

- Filters particles from the air

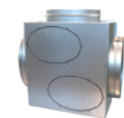

BR500

Plenum for return grille

- To connect 1 up to 4 circular ducts to the return air grille
- Diameter 250mm

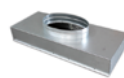

AZCEZDAPR07*

Plenum for return air

- To connect 1 up to 4 circular ducts to the Daikin concealed ceiling units
- Diameter 250mm
- Different sizes (XS, S, M, L, XL) to fit the indoor unit

DCC601A51

Advanced centralised controller



- Intuitive and user-friendly interface
- Flexible concept for stand alone applications
- Total solution thanks to integration of 3rd party equipment

Local solution

- Offline centralised control
- Stylish optional screen fits any interior

System layout





Total solution

- Total solution thanks to a large integration of Daikin products and 3rd party equipment
- Connect a wide range of units (Split, Sky Air, VRV, Ventilation, Biddle air curtains)
- Simply control your entire building centrally
- Increased customer shopping experience by better management of your shop comfort level

User friendly touch control

- Stylish Daikin supplied optional screen for local control fits any interior
- Intuitive and user-friendly interface
- Full solution with simple control
- Easy commissioning

Flexible

- Pulse/digital inputs for 3rd party equipment such as kWh meters, emergency input, window contact, ...
- Control up to 32 indoor units per controller and 320 units per site

(1) only available in combination with certain indoor units

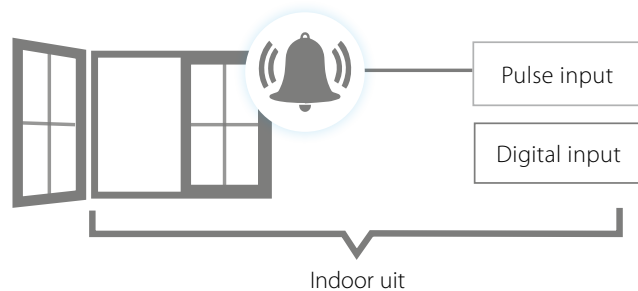

Functions overview

		Local solution
Languages		Depends on local device
System layout	N° of connectable indoor units	32
	Multiple sites control	
Monitoring & control	Basic control functions (ON/OFF, mode, filter sign, setpoint, fan speed, ventilation mode, room temperature, ...)	●
	Remote control prohibition	●
	All devices ON/OFF	●
	Zone control	
	Group control	●
	Weekly schedule	●
	Yearly schedule	
	Interlock control	●
	Set point limitation	
	Visualisation of energy use per operation mode	
Connectable to	DX split, Sky Air, VRV	●
	Modular L Smart, VAM, VKM ventilation	●
	Air curtains	●

For available Daikin Cloud Service options refer to the option list

DCM601B51

Mini BMS with full integration across all product pillars

- Price competitive mini BMS
- Cross-pillar integration of Daikin products
- Integration of third party equipment

 Intelligent Manager



Download the WAGO selection tool from my.daikin.eu

- Easy selection of WAGO materials
- Material list creation
- Time saving
- Includes wiring schemes
- Contains commissioning/preset data for iTM



Check on
You Tube

<https://www.youtube.com/DaikinEurope>

System overview

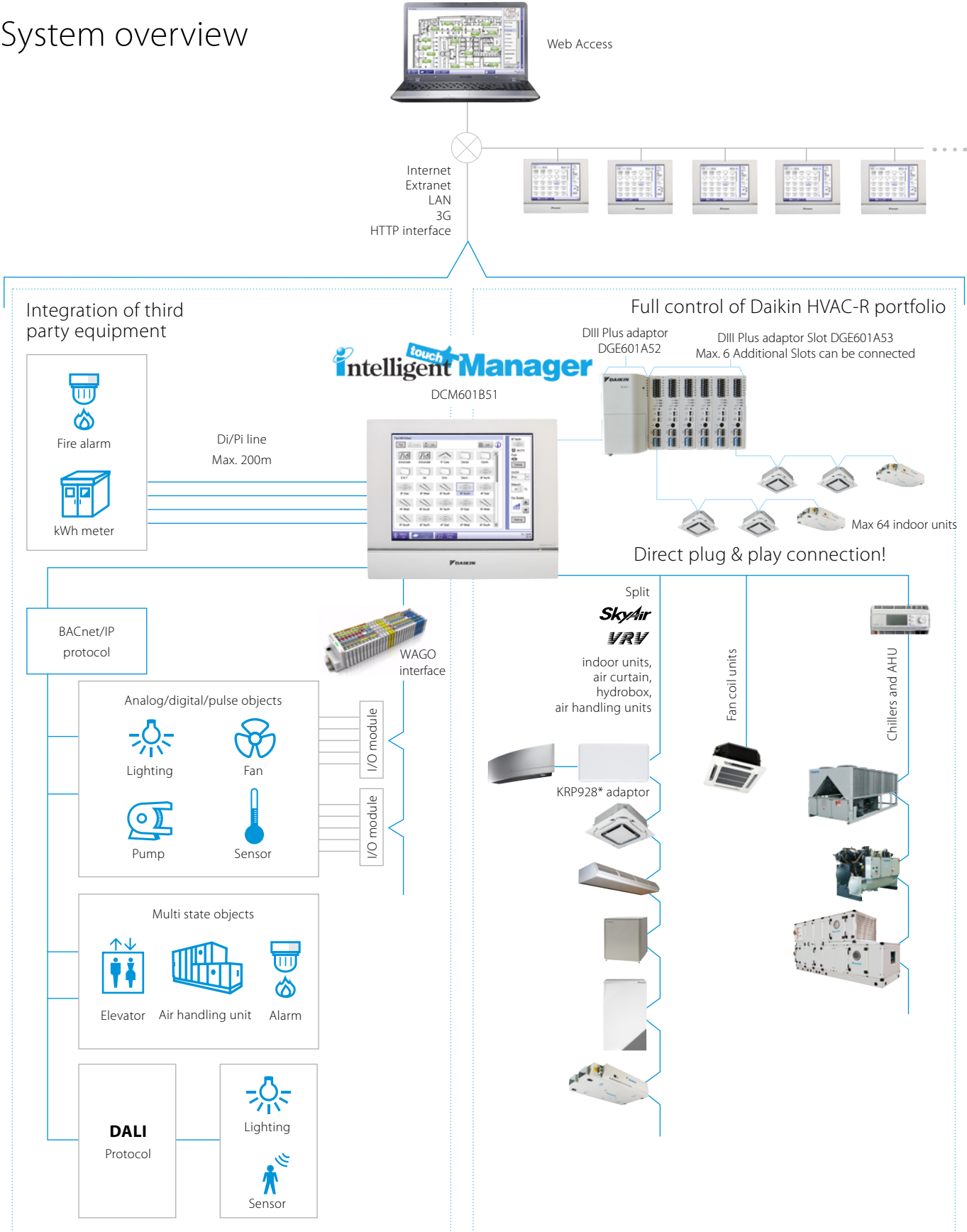

CENTRALISED CONTROL SYSTEMS

User friendliness

- Intuitive user interface
- Visual lay out view and direct access to indoor unit main functions
- All functions direct accessible via touch screen or via web interface
- Simplified electrical wiring, only one power supply & one connection wiring required

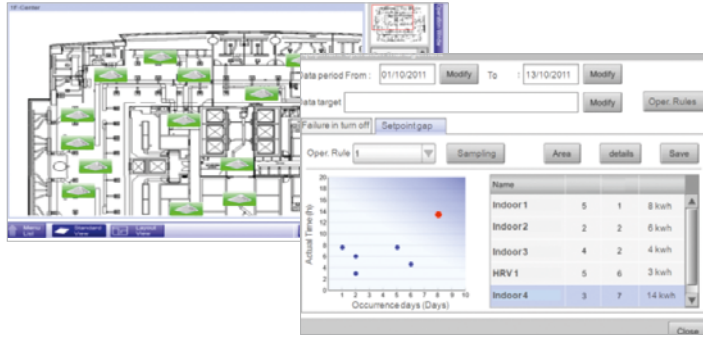

Smart energy management

- Monitoring if energy use is according to plan
- Helps to detect origins of energy waste
- Powerful schedules guarantee correct operation throughout the year
- Save energy by interlocking A/C operation with other equipment such as heating
- Peak Power Cut off Control: Activating this feature in schedule function allows users to operate the outdoor unit in 4 settings i.e. 100%,70%, 40% and 0%

Flexibility

- Cross-pillar integration (heating, air conditioning, applied systems, refrigeration, air handling units)
- BACnet protocol for 3rd party products integration
- I/O for integration of equipment such as lights, pumps... on WAGO modules
- Modular concept for small to large applications
- Control up to 512 indoor unit groups via one ITM and combine multiple ITM via web interface

Easy servicing and commissioning

- Remote refrigerant containment check reducing on site visit
- Simplified troubleshooting
- Save time on commissioning thanks to the pre-commissioning tool
- Auto registration of indoor units

Plug & play

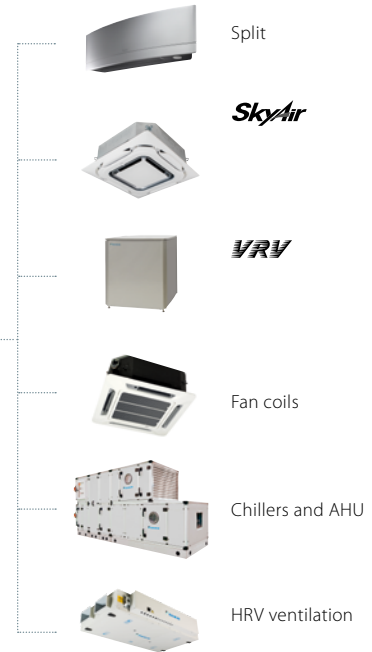

Flexibility in size
64 up to 512 groups

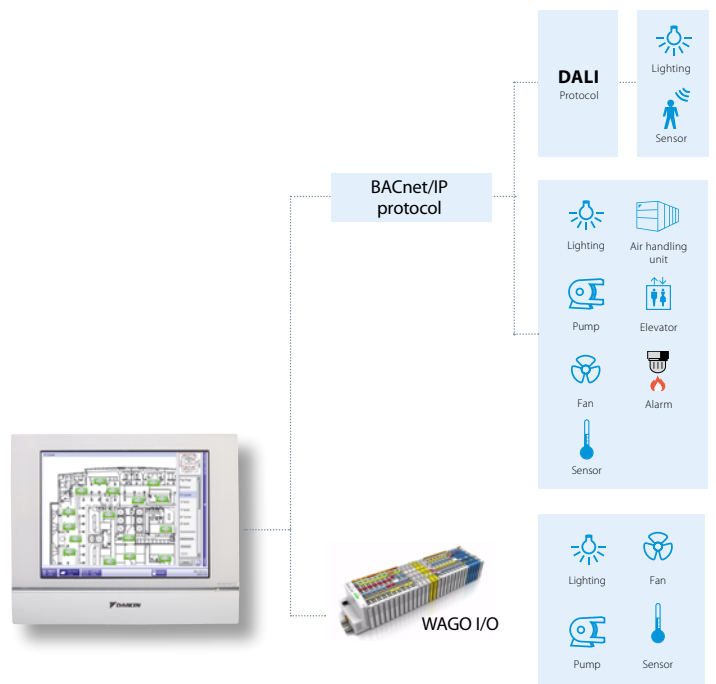

Functions overview

Languages

- English
- French
- German
- Italian
- Spanish
- Dutch
- Portuguese

Management

- Multi site management
- Web access via html 5
- Power Proportional Distribution (option)
- Operational history (malfunctions, ...)
- Smart energy management
- monitor if energy use is according to plan
- detect origins of energy waste
- Setback function
- Sliding temperature
- E-mail notification
- Icon and Floor map view

WAGO Interface

- Modular integration of 3rd party equipment
- Large variety of input and outputs available. For more details refer to the options list

Open http interface

- Communication to any third party controller (domotics, BMS, etc.) is possible via http open interface (http option DCM007A51)

System layout

- Up to 512 indoor unit groups can be controlled (ITM + 7 iTM Plus adapters)
- Up to 56 connectable outdoor units
- Up to 650 connectable management points (with I/O module)

Control

- Group monitoring and control
- Schedule setting (Weekly schedule, yearly calendar, seasonal schedule)
- Interlock control
- Setpoint limitation
- Temperature limit
- Schedule function to activate quiet operation mode on outdoor unit
- Air purification control & Air quality level display (CO₂ level display possible with BRYMA sensor)
- Duty rotation and backup operation
- Remote control prohibition
- Demand control

DALI integration

- Control and monitor the lights
- Easier facility management: receive error signal when light or light controller has a malfunction
- Flexible approach and less wiring needed, compared to classic light scheme
- Easier to make groups and control scenes
- Connection between intelligent Touch Manager and DALI through WAGO BACnet / IP interface

Connectable to

- DX Split, Sky Air, VRV
- HRV
- Chillers (via MT3-EKCBACIP controller)
- Daikin AHU (via MT3-EKCBACIP controller)
- Fan coils
- LT and HT hydroboxes
- Biddle Air curtains
- WAGO I/O
- BACnet/IP protocol
- Daikin PMS interface (option DCM010A51)





Introduction to Daikin Cloud Plus



Daikin Cloud Plus is a cloud-based remote control and monitoring solution for Daikin commercial HVAC installations. Using enhanced control, monitoring and predictive logic, Daikin Cloud Plus provides real-time data and support from Daikin experts to help you identify cost-saving opportunities, increase the lifetime of your equipment and reduce the risk of unexpected issues.

The ultimate control over your indoor climate and air quality

- Save energy & reduce costs
- Enhance comfort & satisfaction
- Smart control from anywhere
- Ensure healthy indoor environment
- Maximize uptime (remote prediction, monitor & diagnose)
- Integrates easily with building systems

Supporting your business and helping you succeed

- Maximize comfort and satisfaction of your staff, customers, tenants, ...
- Save energy & reduce costs
- Facilitate your sustainability goals
- Cost effective control and energy monitoring of HVAC and other facility systems such as lighting
- Limits the necessity for on-site interventions
- Minimizes downtime and engineer call outs

Benefits

Easy control of multiple sites

- Remote control and manage sites remotely
- Floor plan control per site
- Multi-site access
- Permission based access

Save energy & meet sustainability goals

- Monitor energy consumption trends
- Smart control of systems to save energy
- Insights to improve HVAC system performance
- Reduced costs
- Contribute to carbon neutrality

Connectivity and integration possibilities

- Simple to advanced edge controllers
- Various interfaces
- Advanced security

Manage, monitor and control indoor climate from anywhere

- Limits the necessity for on-site control
- Minimizes downtime and engineer call outs
- Optimized maintenance
- Monitoring of indoor air quality

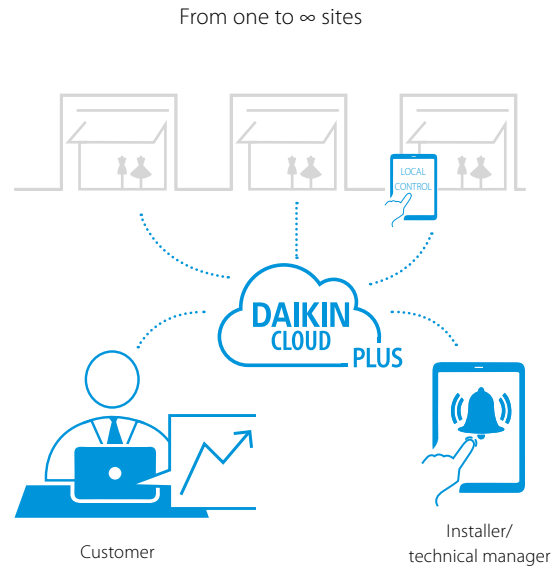

Main applications

Light commercial and commercial systems



Non-food retailers



Hotels



Offices



Schools



Healthcare

Ranges

VRV and Sky Air, air curtains. Integration through I/O. BACnet client available in 2024.

- Direct integration with lights and other facility systems using Daikin Cloud Plus as master of the building
- Integration with BMS, Daikin Cloud Plus as part of the system



Cloud application interface

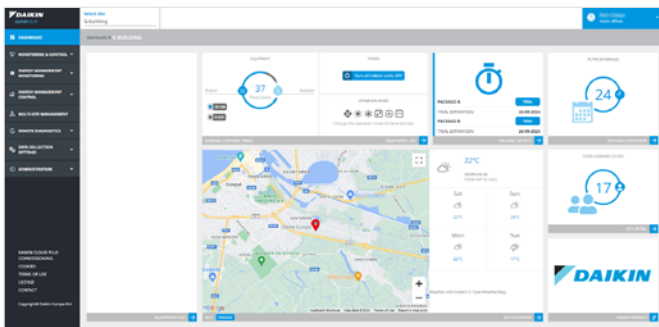

Dashboard

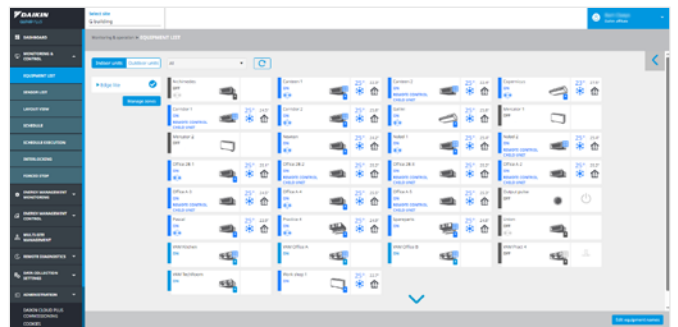

Equipment List

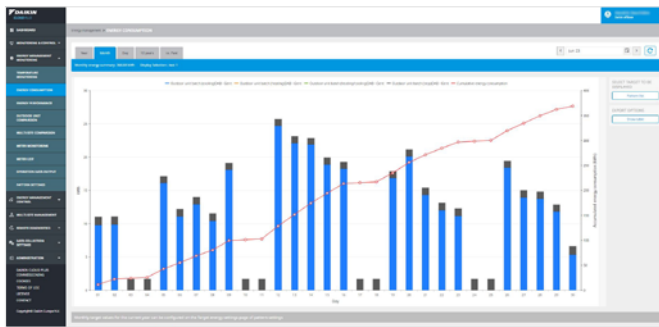

Energy Consumption



Layout View

* Features depend on unit compatibility and region.
Images are indicative and might change if the product evolves.



What can Daikin Cloud Plus do for you?

Were you aware that HVAC systems account for as much as 40% of the total energy consumption in buildings?

- Daikin Cloud Plus logs historical data and allows you to monitor, compare HVAC consumption
- Daikin Cloud Plus allows you to integrate with energy meters so you can monitor not only HVAC but also other energy consumers (facility, gas, water, ...)
- Daikin Cloud Plus allows you to configure and control the system smarter to save energy with restrictions, interlocking rules, schedules, etc.

Are you interested in tracking the progress of sustainability goals or the sustainability policies you put into action?

- Daikin Cloud Plus allows you to monitor, analyse and compare HVAC energy consumption
- Daikin Cloud Plus allows you to remote control and manage new cooling or heating related policies (e.g. heating setpoint of 1° lower)

How do you ensure maximum comfort and minimal interruptions of cooling and heating?

- Daikin Cloud Plus can predict failures to anticipate and prevent unplanned downtime of the heating or cooling
- Daikin Cloud Plus real-time system error notifications to ensure a direct response in case something goes wrong
- Daikin Cloud Plus logs all events in the system and visualized the temperature evolutions
- Daikin Cloud Plus remote system access to indoor and outdoor unit operational data reduces engineering visits on site

How to manage and remote control one or multi-site building estate and apply uniformization in climate control?

- Daikin Cloud Plus allows you to monitor, manage and control multiple sites from anywhere
- Daikin Cloud Plus allows to compare multiple sites

How give peace of mind about indoor air quality?

- Daikin Cloud Plus integrates with IAQ sensors and can take automated actions or provide warnings where needed
- Daikin Cloud Plus allows to monitor and analyse the indoor air quality in order to take necessary actions

How to control my other systems at the facility?

- Daikin Cloud Plus provides possibilities to integrate with other facility systems as a stand-alone system, such as integration with lighting system
- Daikin Cloud Plus provides possibilities to integrate with other facility management systems like BMS or BEMS

Main features



Remote Control, Demand Control and Scheduling

Control and monitor the climate of your buildings at any time, from anywhere. From a web browser, it is possible to adjust your units' parameters, including temperature setpoints, fan speeds, heating or cooling operation modes and much more. All these parameters can be scheduled for maximum convenience during weekdays, weekends, holidays, office hours, opening hours, etc. Schedules are stored on the controller so the units are functioned as scheduled despite the internet connection. Additionally, units can be positioned in a visual floor plan to make it easier to locate an unit and change the setpoints remotely. Demand control reduces the peak consumption with minimal impact on comfort by predicting future needs and adjusting the operational capacity of the units accordingly.



Multi-site Management

Get a map view of all your sites with status alerts, benchmark and compare sites to one another. From the map view, you can get direct access to each site to monitor and control the site remotely. This helps to reduce site visits and get insights that lead to opportunities for reducing operational costs while maintaining great comfort levels.



Building Integration

Not only HVAC but other facilities in the buildings can be controlled from the central platform. For example, the lighting system can be included in schedules and integrated with interlocking to have one single point of control and optimize energy efficiency for your buildings.



Energy Monitoring

Get detailed visualization and export energy data of your buildings. Powerful graphs, comparisons and visualisations are available to help you assess the performance and potential improvements to reduce excessive energy and lower your energy costs. Next to detailed energy data of HVAC systems, it is possible to add external meters to measure consumption of lighting and water systems.



Alarm History & Email Notification

Get detailed overview of alarms relating to your sites and real-time status of the alarms. Receive alarms notification email with access to alarm details on Daikin Cloud Plus platform.



Power Consumption Distribution

Proportional distribution of power consumption allows you to calculate the consumption for specific areas in your buildings. For example, you can calculate how much power is used by a tenant on a certain floor. For this function, energy meters are required.



Interlocking

Smart rules can be integrated to optimize the operation of your units by setting specific triggers and scheduling necessary actions when these conditions happen. Through "if this, then that" principle, both the comfort of users and the efficiency of units can be optimized. For example, a rule can be: "Trigger: if a window is open then take the Action: after 5 min turn off the air conditioner". Furthermore, the system enables setting restrictions remotely. For example, a user can only change the temperature between certain limits, which gives users control over their comfort while restricting extreme settings.



Remote Field Settings

Field settings of outdoor units can be adjusted remotely. This allows technicians and building operators to adjust, configure and monitor outdoor units from a distance, reducing the need to be at the location, save time and costs associated with travel, labour and maintenance, increase efficiency and overall performance.



Site History

Trace schedule trigger units or manual actions that were done on the units and sites. Past events, changes, and adjustments, enabling you to identify trends, gauge performance improvements, and strategize for the future. By drawing from historical data, you'll make informed decisions, adapt strategies, and drive continuous enhancements, revolutionizing your HVAC management approach.



Prediction & Email Notification

Early fault predictive algorithms help to prevent major failures. Based on the alarm and operational data, unit-specific prediction logic allows you to preventively, see whether a unit could run into issues. Prediction logic alarms will be generated in this case, allowing early warnings and ensuring smooth operation.



Operational Data Access

Effortlessly monitor, analyse, and fine-tune HVAC parameters remotely, enabling you to make informed decisions on the go. Real-time access to operational data, performance metrics, and energy usage empowers you to adjust settings, troubleshoot anomalies, and maintain peak efficiency, all while minimizing the need for physical intervention. Operational data can be downloaded for further analysis and periodical reporting.



Indoor & Outdoor Unit Analysis

Dive into comprehensive insights into each unit's performance, energy consumption, and environmental impact. Seamlessly compare data across units, pinpointing inefficiencies and optimizing your system's overall effectiveness. With a holistic view of indoor and outdoor units, you'll achieve unprecedented levels of operational harmony and energy savings.

Use cases



For retailers

- Remote control and monitoring of all units in different shops from a centralized platform
- Testing and validating parameters and standardizing settings for shops
- Energy visualizations and exports
- Remote control over lightings



For hotels

- Setting temperature ranges for rooms to avoid extreme settings by guests
- Energy monitoring
- Scalability made easier thanks to standardized system settings



For offices

- Setting temperature ranges for office areas to avoid extreme settings by staff
- Detailed energy monitoring and export of data per tenant of different office areas
- Estimation of energy consumption and setting the right pricing for each tenant
- Scheduling and restrict controls to avoid energy waste and save energy costs

* Features depend on unit compatibility and region.

Images are indicative and might change if the product evolves.



CENTRALISED CONTROL SYSTEMS

Controllers & accessories

Controllers and their connections

Composition



Internet Connection

USER INTERFACE

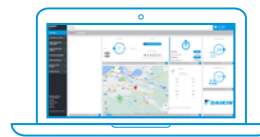

Remote control and monitoring



IAQ control and monitoring



Maintenance and diagnostics



Multi-site management



Energy control, monitoring and insights



Demand Control



BUILDING

Limited local app (optional)

Local fallback function in case of internet disconnection



Other connections
WAGO, BACnet, Di/Pi

Edge controller and adapters

1.



DC+ Edge (DGE601A51)



DGPf DIII Plus ADP (DGE601A52)

+



DGPf DIII Plus ADP SLOt (DGE601A53)

2.



DC+ Edge lite (DGE602A51)



Controller Features

			DGE601A51 (Edge)	DGE602A51 (Edge lite)
Controller specification	I/F	DIII port	2	1
		(Indoor unit connection / port)	64	64
		Ethernet	1	1
		2nd LAN port (BACnet)	1(N.A. yet)	0
		RS485	1	0
	ADP	For DIII NET Plus ADP	1	0
		(Maximum expansion)	6	
	Contact	Di/Pi	8	4
		Do	3	2
	Number of connection	DIII management points	Standard	128
Maximum with ADP			512	-
Total management points		Including AC and other facilities	1,000	76

Functions overview

Maximum connectable indoor units	512
Maximum connectable management point with I/O module	960
Group monitoring and control	✓
Icon / Floor map view	✓
Timer extension	✓
Error/Status monitoring & history saving	✓
Malfunction prediction logic	✓
IAQ interlocking	✓
IAQ visualization	✓
E-mail error reporting	✓
R/C prohibition	✓
Multisite management	✓
Schedule (Yearly, Monthly, Weekly, Special days)	✓
Interlocking	✓
Advanced power saving function (e.g. demand control)	✓
Remote maintenance	✓
Defrost changeover/Anti-frost*	✓
Target evaporating/condensing temperature*	✓
Capacity priority*	✓
Low noise operation*	✓
Leakage detection alarm*	✓
Proportional power distribution (PPD)	✓
Energy consumption monitoring	✓
3rd Party Integration (IFTTT, Alexa, Siri, etc)	✘
Cross-pillar products (e.g. DHW, Chillers)	✘

Individual Modbus interfaces

RTD-RA

- Modbus interface for monitoring and control of residential indoor units

DAIKIN MODBUS ADAPTOR SIMPLE (EKMBPP1)

NEW

- Modbus interface for monitoring & control of Sky air, VRV & ventilation units.
- Smart grid control for Sky air indoor units.

RTD-10

- Advanced integration into BMS of Sky Air, VRV, VAM and VKM through either:
 - Modbus
 - Voltage (0-10V)
 - Resistance
 - Duty/standby function for server rooms

RTD-20

- Advanced control of Sky Air, VRV, VAM/VKM and air curtains
- Clone or independent zone control
- Increased comfort with integration of CO₂ sensor for fresh air volume control
- Save on running costs via
 - pre/post and trade mode
 - set point limitation
 - overall shut down
- PIR sensor for adaptive deadband

RTD-HO

- Modbus interface for monitoring and control of Sky Air, VRV, VAM and VKM
- Intelligent hotel room controller

RTD-W

- Modbus interface for monitoring and control of Daikin Altherma Flex Type, VRV HT hydrobox and small inverter chiller

Daikin HomeHub EKRHH **NEW**

- Modbus RTU/IP interface for Daikin Altherma 3
- Integrate the Daikin Altherma 3 air-to-water heat pump in a home automation or energy management system

DCOM-LT/MB

- Modbus interface of Daikin Altherma air-to-water heat pumps, hybrid heat pumps and ground source heat pumps

DCOM/LT-IO

- Voltage & resistance control in addition to Modbus



Overview functions



Main functions	RTD-RA	EKMBPP1	RTD-10	RTD-20	RTD-HO
Dimensions H x W x D mm	80 x 80 x 37.5	100 x 100 x 20		100 x 100 x 22	
Key card + window contact					✓
Set back function	✓				✓
Prohibit or restrict remote control functions (setpoint limitation, ...)	✓	✓	✓	✓**	✓
Modbus (RS485)	✓	✓	✓	✓	✓
Group control	✓(1)	✓	✓	✓	✓
0 - 10 V control			✓	✓	
Resistance control			✓	✓	
IT application	✓		✓		
Heating interlock			✓		
Output signal (on/defrost, error)			✓	✓****	✓
Retail application				✓	
Partitioned room control				✓	
Air curtain		✓***	✓***	✓	

(1): By combining RTD-RA devices

Control functions	RTD-RA	EKMBPP1	RTD-10	RTD-20	RTD-HO
On/Off	M,C	M	M,V,R	M	M*
Set point	M	M	M,V,R	M	M*
Mode	M	M	M,V,R	M	M*
Fan	M	M	M,V,R	M	M*
Louver	M	M	M,V,R	M	M*
HRV Damper control		M	M,V,R	M	
Prohibit/Restrict functions	M	M	M,V,R	M	M*
Forced thermo off	M				
Smart Grid Control		M			

Monitoring functions	RTD-RA	EKMBPP1	RTD-10	RTD-20	RTD-HO
On/Off	M	M	M	M	M
Set point	M	M	M	M	M
Mode	M	M	M	M	M
Fan	M	M	M	M	M
Louver	M	M	M	M	M
RC temperature		M	M	M	M
RC mode		M	M	M	M
N° of units		M	M	M	M
Fault	M	M	M	M	M
Fault code	M	M	M	M	M
Return air temperature (Average/Min/Max)	M	M	M	M	M
Filter alarm		M	M	M	M
Termo on	M	M	M	M	M
Defrost		M	M	M	M
Coil In/Out temperature	M	M	M	M	M



Main functions	RTD-W
Dimensions H x W x D mm	100x100x22
On/off prohibition	✓
Modbus RS485	✓
Dry contact control	✓
Output signal (operation error)	✓
Space heating / cooling operation	✓
Domestic hot water control	✓
Smart Grid control	

Control functions	RTD-W
On/Off Space heating/cooling	M,C
Set point leaving water temperature (heating / cooling)	M,V
Room temperature setpoint	M
Operation mode	M
Domestic Hot water ON	
Domestic Hot Water reheat	M,C
Domestic Hot Water reheat setpoint	
Domestic Hot Water storage	M
Domestic Hot Water Booster setpoint	
Quiet mode	M,C
Weather dependent setpoint enable	M
Weather dependent curve shift	M
Fault/pump info relay choice	
Control source prohibition	M

Smart grid mode control	RTD-W
Prohibit Space heating/cooling	
Prohibit DHW	
Prohibit Electric heaters	
Prohibit All operation	
PV available for storage	
Powerful boost	

Monitoring functions	RTD-W
› On/Off Space heating/cooling	M,C
› Set point leaving water temperature (H/C)	M
› Room temperature setpoint	M
› Operation mode	M
› Domestic Hot Water reheat	M
› Domestic Hot Water storage	M
› Number of units in the group	M
› Average leaving water temperature	M
› Remocon room temperature	M
› Fault	M,C
› Fault code	M
› Circulation pump operation	M
› Flow rate	
› Solar pump operation	
› Compressor status	M
› Desinfection operation	M
› Setback operation	M
› Defrost/ start up	M
› Hot start	
› Booster Heater operation	
› 3-Way valve status	
› Pump running hours accumulated	M
› Compressor running hours accumulated	
› Actual leaving water temperature	M
› Actual return water temperature	M
› Actual DHW tank temperature (*)	M
› Actual refrigerant temperature	
› Actual outdoor temperature	M

Control functions	EKRHH
Leaving water main heating or cooling setpoint	✓
Operation mode	✓
Space heating/cooling ON/OFF	✓
Room thermostat control heating or cooling setpoint	✓
Room thermostat ON/OFF	✓
Quiet mode ON/OFF	✓
DHW reheat set point	✓
DHW reheat ON/OFF	✓
DHW powerful mode ON/OFF	✓
Weather dependent mode and offset	✓
SG operation mode	✓
Power limit during recommended on / buffering	✓
General power limit	✓

Monitoring functions	EKRHH
Error code	✓
Circulation pump running	✓
Compressor running	✓
Backup heater running	✓
Disinfection operation	✓
Defrost/startup/hot start	✓
Operation mode	✓
Leaving water temperature PHE/BUH	✓
Return water temperature	✓
Domestic hot water temperature	✓
Ambient temperature	✓
Liquid refrigerant temperature	✓
Flowrate	✓
Room temperature	✓
Heat pump power consumption	✓
DHW operation / space heating operation	✓
Leaving water temperature lower and upper limit	✓

M: Modbus / R: Resistance / V: Voltage / C: control | * : only when room is occupied / ** : setpoint limitation / (*) if available | ***: no fan speed control on the CVV air curtain / ****: run & fault

EKMBDXB

DIII-net Modbus interface

Integrated control system for seamless connection between Split, Sky Air, VRV and small inverter chillers and BMS systems

- Communication via Modbus RS485 protocol
- Detailed monitoring and control of the VRV total solution
- Easy and fast installation via DIII-net protocol
- As the Daikin DIII-net protocol is being used, only one modbus interface is needed for a group of Daikin systems (up to 10 outdoor units systems).

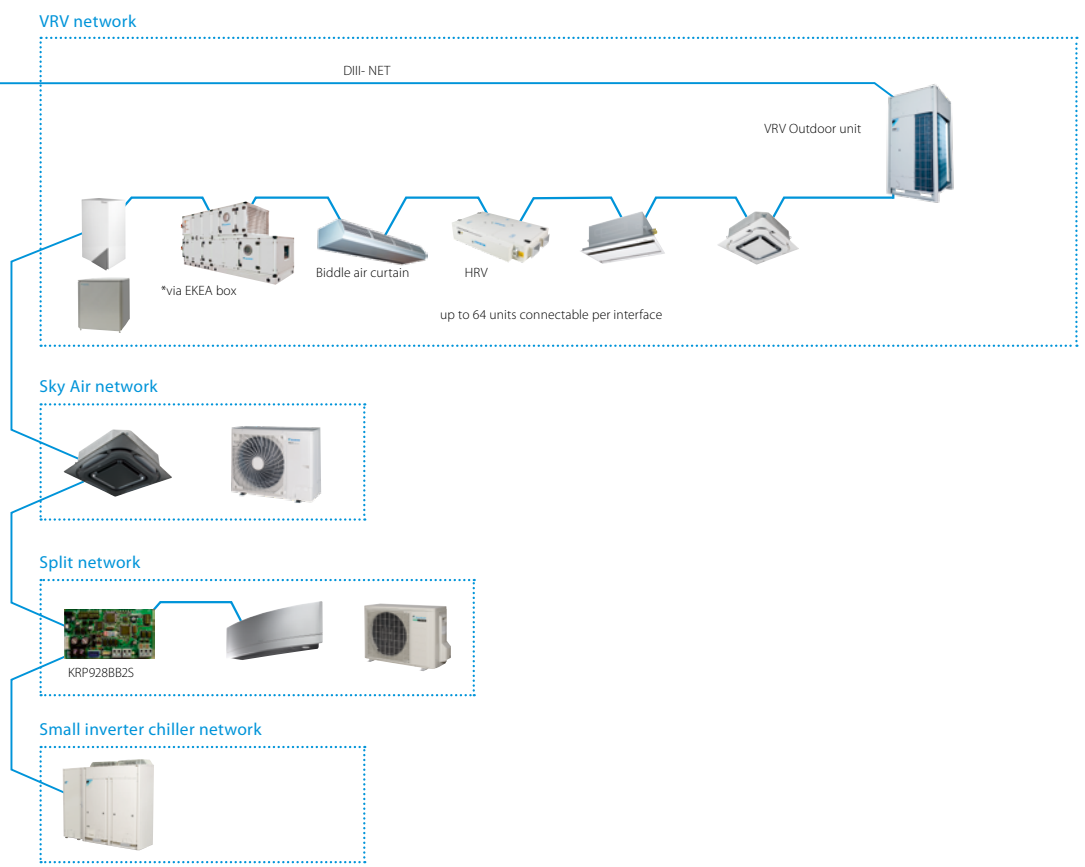

Building control network

- Fire alarm
- Security
- Power supply facility
- Lighting
- Pump
- Elevator

Functions overview

		EKMBDXB7V1	
Maximum number of connectable indoor units		64	
Maximum number of connectable outdoor units		10	
Communication	DIII-NET - Remark	DIII-NET (F1F2)	
	Protocol - Remark	2 wire; communication speed: 9,600 bps or 19,200 bps	
	Protocol - Type	RS485 (modbus)	
	Protocol - Max. Wiring length	m	500
Dimensions	HeightxWidthxDepth	mm	124x379x87
Weight		kg	2.1
Ambient temperature - operation	Max.	°C	60
	Min.	°C	0
Installation		Indoor installation	
Power supply	Frequency	Hz	50
	Voltage	V	220-240

		Modbus EKMBDXB	
Maximum connectable indoor units			64
Maximum connectable outdoor units			10
Controlling	On/Off		✓
	Operation mode		✓
	Temperature		✓
	Airflow		✓
	Filter sign reset		✓
	System forced off		✓
	User interface lock		✓
	Quiet (low noise) mode		✗
	Energy saving control		✗
	Monitoring	Error, alarm and warning/malfunction status	
Indoor statuses (Temperature, fan speed and direction, etc)			✓
Outdoor compressor status			✗
Energy consumption (PPD)			✗

KLIC-DDV3
KLIC-DI_V2

KNX interface

Integration of Split, Sky Air and VRV in HA/BMS systems

Connect split indoor units to KNX interface for Home Automation system

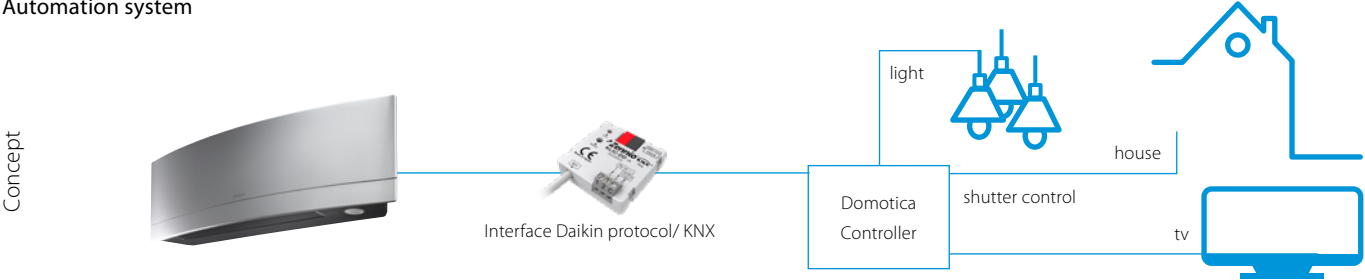

Connect Sky Air / VRV indoor units to KNX interface for BMS integration

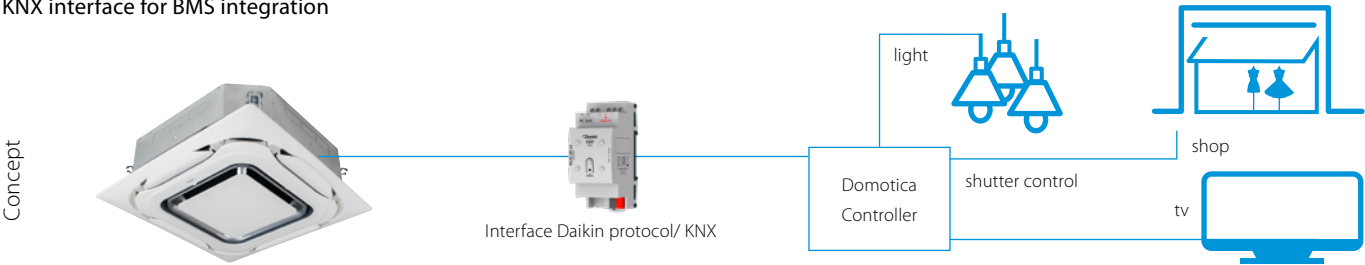



KNX interface line-up

The integration of Daikin indoor units through the KNX interface allows monitoring and control of several devices, such as lights and shutters, from one central controller. One particularly important feature is the ability to programme a 'scene'

- such as "Home leave" - in which the end-user selects a range of commands to be executed simultaneously once the scenario is selected. For instance in "Home leave", the air conditioner is off, the lights are turned off, the shutters are closed and the alarm is on.

KNX interface for

	 KLIC-DDV3 size 45x45x15mm Split	 KLIC-DI_V2 size 90x60x35mm Sky Air	VRV
Basic control			
On/Off	•	•	•
Mode	Auto, heat, dry, fan, cool	Auto, heat, dry, fan, cool	Auto, heat, dry, fan, cool
Temperature	•	•	•
Fan speed levels	3 or 5 + auto	2 or 3	2 or 3
Swing	Stop or movement	Stop or movement	Swing or fixed positions (5)
Advanced functionalities			
Error management		Communication errors, Daikin unit errors	
Scenes	•	•	•
Auto switch off	•	•	•
Temperature limitation	•	•	•
Initial configuration	•	•	•
Master and slave configuration		•	•

K.RSS

Wireless room temperature sensor for Sky Air and VRV

Flexible and easy installation

- Accurate temperature measurement thanks to flexible placement of the sensor
- No need for wiring
- No need to drill holes
- Ideal for refurbishment



Connection diagram Daikin indoor unit PCB (FXSQ example)



Specifications

			Wireless room temperature sensor kit (K.RSS)	
			Wireless room temperature receiver	Wireless room temperature sensor
Dimensions	mm		50x50	ø 75
Weight	g		40	60
Power supply			16VDC, max. 20 mA	N/A
Battery life			N/A	+/- 3 years
Battery type			N/A	3 Volt Lithium battery
Maximum range	m			10
Operation range	°C			0~50
Communication	Type			RF
	Frequency	MHz		868.3

› Room temperature is sent to the indoor unit every 90 seconds or if the temperature difference is 0.2°C or larger.

KRCS*

Wired room temperature sensor for Sky Air and VRV

- Accurate temperature measurement, thanks to flexible placement of the sensor
- Specific model code for each indoor unit can be found in the option tables



Specifications









Dimensions (HxW)	mm	60x50
Weight	g	300
Length of branch wiring	m	12

Adapter PCBs

Simple solutions for unique requirements



Concept and benefits

- Low cost option to satisfy simple control requirements
- Deployed on single or multiple units

			Connectable to:		
			Split	Sky Air	VRV
	(E)KRP1B* adapter for wiring	<ul style="list-style-type: none"> › Facilitates integration of auxiliary heating apparatus, humidifiers, fans, damper › Powered by and installed at the indoor unit 		●	●
	KRP2A*/KRP4A* Wiring adapter for electrical appendices	<ul style="list-style-type: none"> › Remotely start and stop up to 16 indoor units (1 group) (KRP4A* via F1 F2) › Remotely start and stop up to 128 indoor units (64 groups) (KRP2A* via P1 P2) › Alarm indication/ fire shut down › Remote temperature setpoint adjustment › Cannot be used in combination with a central controller 		●	●
	SB.KRP58M2	<ul style="list-style-type: none"> › Low noise and demand control option for RZAG-N* and RZASG-M* series. › Obligatory mounted plate EKMKS2A needs to be ordered separately 		●	
	KRP58M51	<ul style="list-style-type: none"> › Low noise and demand control option for RZA-D series. › Includes obligatory mounted plate EKMKS3A › Obligatory mounting plate EKMKS3A3 needs to be ordered separately 		●	
	DTA104A* Outdoor Unit External Control Adapter	<ul style="list-style-type: none"> › Individual or simultaneous control of VRV system operating mode › Demand control of individual or multiple systems › Low noise option for individual or multiple systems 			●
	DCS302A52-9 Unification adapter for computerized control	<ul style="list-style-type: none"> › Enables unified display (operation/malfunction) and unified control (ON/OFF) from BMS system › Must be used together with Intelligent Touch Controller or intelligent Touch Manager › Cannot be combined with KRP2/4* › Can be used for all VRV indoor models 			●
	KRP928* Interface adapter for DIII-net	<ul style="list-style-type: none"> › Allows integration of split units to Daikin central controls 	●		
	KRP980* Adapter for split units without an S21 port	<ul style="list-style-type: none"> › Connect a wired remote control › Connect to Daikin central controls › Allow external contact 	●		
	KRP413* Wiring adapter normal open contact / normal open pulse contact	<ul style="list-style-type: none"> › Switch off auto restart after power failure › Indication of operation mode / error › Remotely start / stop › Remotely change operation mode › Remotely change fan speed 	●		

Some adapters require an installation box, refer to the option lists for more information

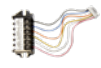
Accessories

EKRORO		<ul style="list-style-type: none"> ▪ External ON/OFF or forced off ▪ Example: door or window contact
EKRORO 3		<ul style="list-style-type: none"> ▪ External ON/OFF or forced off ▪ F1/F2 contact ▪ Example: door or window contact
KRC19-26A		<ul style="list-style-type: none"> ▪ Mechanical cool/heat selector ▪ Allows switching over an entire system between cooling/heating/fan only ▪ Connects to the A/B/C terminals of the unit
BRP2A81		<ul style="list-style-type: none"> ▪ Cool/heat selector PCB ▪ Required to connect KRC19-26A to a VRV IV+ outdoor unit



Auto-cleaning panel

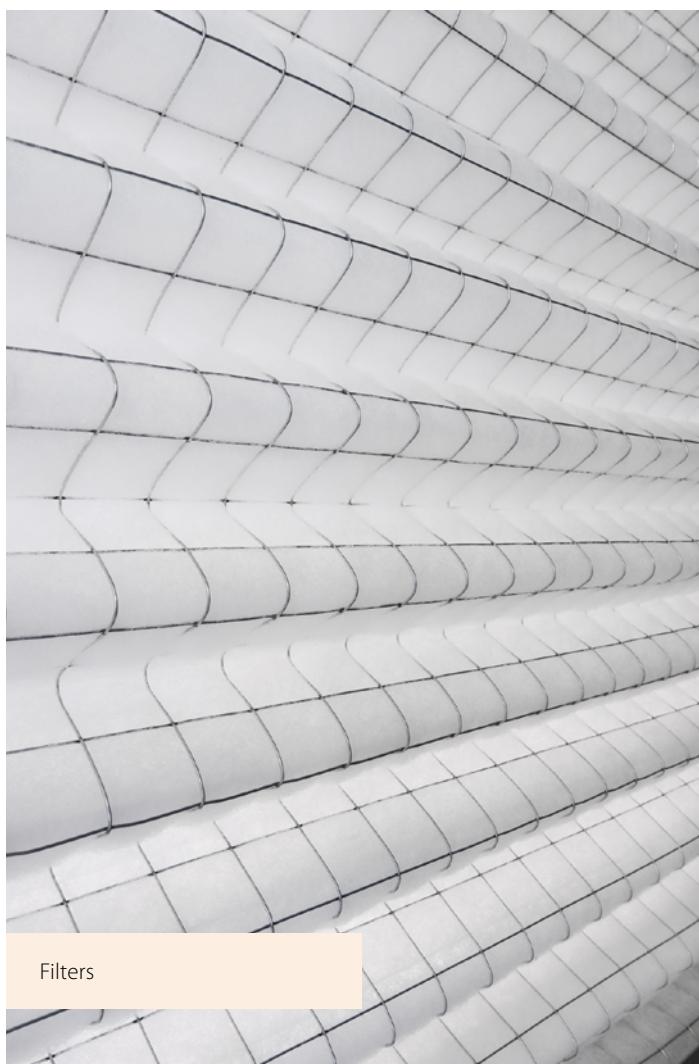

Filters



Intelligent sensors

Options & Accessories

Sky Air	140
▪ Indoor units	140
▪ Outdoor units	142
Rooftops	143
Ventilation	144
Control systems	148

Options - Sky Air

		FCAHG-H FCAG-B	FFA-A9	FDXM-F9	FBA-A(9)		
INDOOR UNITS							
Panels	Decoration panel (obligatory for cassette units, optional for others)		Standard panels: BYCQ140E (white) / BYCQ140EW (full white)(1) / BYCQ140EB (black) Auto cleaning panels(2) (4): BYCQ140EGF (white) / BYCQ140EGFB (black) Designer panels: BYCQ140EP (white) / BYCQ140EPB (black)	BYFQ60C2W1W (white panel) BYFQ60C2W1S (grey panel) BYFQ60B3W1 (standard panel)			
	Panel spacer for reducing required installation height			KDBQ44B60 (only for standard panel)			
	Sealing kit for 3- or 2-directional air discharge		KDBHQ56B140 (11)	BDBHQ44C60			
	Sensor kit		BRYQ140B (white) BRYQ140BB (black) BRYQ140C (white designer) BRYQ140CB (black designer)	BRYQ60AW (white)(9) BRYQ60AS (silver)(9)			
Individual control systems	Onecta app		BRP069C82 (14) (18)	BRP069C81 (18)	BRP069C81 (18)		
	Infrared remote control (incl. receiver)		BRC7FA532F (white) (11) (16) BRC7FA532FB (black) (11) (16) BRC7F8532F (designer white) (11) (16) BRC7F8532FB (designer black) (11) (16)	BRC7EB530W for standard panel (5)(6) BRC7F530W for white panel (5)(6) BRC7F530S - for silver panel (5)(6)	BRC4C65	BRC4C65	
	Madoka BRC1H52W (9) (White) / BRC1H52S (9) (Silver) / BRC1K552K (9) (Black) User-friendly wired remote controller with premium design		•	•	•	•	
	BRC1E53A/B/C (3) (13) - Wired remote controller with full-text interface and back-light		•	•	•	•	
Centralised control systems	DIII-net connection - for connection to centralized control		standard	standard	standard	standard	
	DCC601A51 - intelligent Tablet Controller		•	•	•	•	
	DCS601C51 (13) - intelligent Touch Controller		•	•	•	•	
	DCS302C51 (13) - Central remote controller		•	•	•	•	
	DCS301B51 (13) - Unified ON/OFF controller		•	•	•	•	
	Building Management System & Standard protocol interfaces	for individual control	EKMBPP1 - Modbus interface for monitoring and control	•	•	•	•
			RTD-10 - Modbus interface for infrastructure cooling	•	•	•	•
			RTD-20 - Modbus interface for retail	•	•	•	•
		for central control	RTD-HO - Modbus interface for hotel	•	•	•	•
			KLIC-DI_V2 - KNX Interface	•	•	•	•
			DCM601B51 - intelligent Touch Manager	•	•	•	•
	DGE601A51 - Edge adapter for connection to Daikin Cloud Plus		•	•	•	•	
	DGE602A51 - Edge lite adapter for connection to Daikin Cloud Plus		•	•	•	•	
EKMBDXB - Modbus interface	•		•	•	•		
DCM010A51 - Daikin PMS interface	•		•	•	•		
DMS502A51 - BACnet Interface	•	•	•	•			
DMS504B51 - LonWorks Interface	•	•	•	•			
Filters	Auto cleaning filter		see deco panel		BAE20A62 (25 - 35) BAE20A102 (50 - 60)		
	UV Streamer kit (purifies the air of pollutants such as viruses, bacteria, fine dust, odours, allergens, etc ensuring a healthy indoor environment)	UV Streamer kit Replacement filter	BAEF125AWB (22) BAF55A125				
	High efficiency filter		ePM10 60% BAF552AA160 (23) (BAF552AA160-5: box of 5 filters) (BAF552AA160-10: box of 10 filters)				
	Replacement long-life filter, non-woven type		KAF551D160	KAF441C60			
Wiring and sensors	Filter chamber						
	Extension wire auto cleaning panel (required when auto cleaning panel AND Onecta app are both installed)						
	KRCS - External wired temperature sensor		KRCS01-5B SB.K.RSS_RFC (EKEWTSC-2 + K.RSS)	KRCS01-4	KRCS01-4		
K.RSS - External wireless temperature sensor			•		•		
Wiring and sensors Adapters	Wiring adapter with 2 output signals (compressor/ Error, Fan output)		KRP1BA58 (10)(11)	KRP1B57 (10)	KRP1B56 (10)		
	Adapter (interlock for fresh air intake fan)						
	Adapter with 4 output signals (compressor / Error, Fan, Aux, heater, Humidifier output)		EKR1C12 (10)(11)	EKR1B2		EKR1B2 (7)	
	Adapter for centralised external monitoring/control (controls 1 entire DIII-NET system)				KRP2A53 (10)	KRP2A51 (7)(10)	
	Adapter for centralised external monitoring/control via dry contacts and setpoint control via 0-140Ω (for dedicated indoor)		KRP4A53 (10)(11)(17)	KRP4A51	KRP4A54-9	KRP4A52 (10)	
	Adapter for keycard and/or window contact connection (in combination with BRC1H*, BRC1/2/3E* only)		BRP7A53	BRP7A53	BRP7A54 (10)	BRP7A51 (12)	
	Installation box/Mounting plate for adapter PCBs (when there is no space in the switchbox, an installation box is required)		KRP1H98A (11)	KRP4A93	KRP1BC101	KRP1BC101	
Wiring kit for Remote ON/OFF or Forced OFF		standard	standard	standard	standard		
Others	Drain pump kit						
	Multi zoning kit (for detailed model code overview refer to multizoning argue card in this catalogue)				•	•	
	L-type piping kit (upward direction)						
	Fresh air intake kit (direct installation type)		KDDP55C160-1 (chamber) KDDP55D160-2 (diffuser) (11)	KDDQ44XA60			
Air discharge adapter for round duct					KDAP25A56A (35-50) KDAP25A71A (60-71) KDAP25A140A (100-140)		

- (1) Dirt formation is more easily visible on white insulation. It is recommended not to install this option in environments with a high concentration of dirt.
- (2) To be able to control option BYCQ140EG(F)/EGFB, controller BRC1H*, BRC1E* is needed. These options cannot be combined with RXY5SQ*, multi or non-inverter split units
- (3) Included languages are:
A: English, German, French, Dutch, Spanish, Italian and Portuguese
B: English, Bulgarian, Croatian, Czech, Hungarian, Romanian and Slovenian
C: English, Greek, Polish, Russian, Albanian, Slovak and Turkish

- (4) The option is intended exclusively for use in fine dust environments (e.g. Clothing shops). Do not use it in environments that are greasy or have high humidity. F = finer mesh
- (5) Sensing function is not available
- (6) Individual flap control function not available
- (7) If installing an electrical heater, an option PCB for external electrical heater (EKRP1B2) for each indoor unit is required. These options require mounting plate KRP4A96. Electrical heaters and humidifiers are field-supplied. Do not install them inside the equipment.
- (8) Mounting plate KRP4A96 is required for these options. Maximum 2 option PCB's can be mounted.
- (9) This option cannot be used with RR and RQ models

FDA125A	FDA200-250A	ADEA-A	FAA-B	FTXM-R	FHA-A(9)	FUA-A	FVA-A	FNA-A9
BYBSI25D (19)						KDBTP49B140		
						KDBHP49B140		
BRP069C81 (18)	BRP069C82 (20)	BRP069C81 (18)	BRP069C81 (18)	Integrated in PCB	BRP069C81 (18)	BRP069C81 (18)	BRP069C81 (18)	BRP069C81 (18)
BRC4C65	BRC4C65	BRC4C65	BRC7EA631 (71 class) BRC7EA632 (100 class)	ARC466A67	BRC7GA53-9	BRC7C58		BRC4C65
•	•	•	•		•	•	•	•
				• (BRC073A1) BRCW901A03/A08 extension cords available (15)	•	•	•	•
standard	standard	standard	standard	KRP928BB25 (15)	standard	standard	standard	standard
•	•	•	•	• (15)	•	•	•	•
•	•	•	•	• (15)	•	•	•	•
•	•	•	•	• (15)	•	•	•	•
•	•	•	•	• (15)	•	•	•	•
•	•	•	•	• (15)	•	•	•	•
•	•	•	•	• (15)	•	•	•	•
•	•	•	•	• (15)	•	•	•	•
•	•	•	•	• (15)	•	•	•	•
•	•	•	•	• (15)	•	•	•	•
•	•	•	•	• (15)	•	•	•	•
•	•	•	•	• (15)	•	•	•	•
•	•	•	•	• (15)	•	•	•	•
•	•	•	•	• (15)	•	•	•	•
•	•	•	•	• (15)	•	•	•	•
•	•	•	•	• (15)	•	•	•	•
•	•	•	•	• (15)	•	•	•	•
	BAFL502A250 (20)					KAF501B56 (35-50) KAF501B80 (60-71) KAF501B160 (100-140)	KAF551D160	KAFJ95L160
	BDD500B250							
KRCS01-4	KRCS01-6B SB.K.RSS_FDA (EKEWTSC-1 + K.RSS)	KRCS01-4	KRCS01-4		KRCS01-4	KRCS01-4		KRCS01-4
•	•	•			•	•		•
	KRP4A51 (17)		KRP4A51 (10)	KRP413AB15 (15)			KRP1B57 (10)	
KRP1C64 (8)	KRP1C65	KRP1B54			KRP1B54 (10)			
EKRP1B2 (7)	EKRP1C13	EKRP1B2 (7)						KRP1B56
KRP2A51 (8)	KRP2A51 (17)	KRP2A51 (7)(10)						
		KRP4A52 (10)			KRP4A52 (10)	KRP1B97	KRP4A52 (10)	KRP4A54-9
BRP7A54 (8)	BRP7A54	BRP7A51 (12)	BRP7A51 (10)		BRP7A52 (10)	BRP7A53 (10)	BRP7A52 (10)	
KRP4A96		KRP1BC101	KRP4B93		KRP1D93A (21)	KRP1BA97	KRP4AA95	KRP1BB101
EKRORO3		standard	standard		EKRORO4	EKRORO5	standard	standard
	BDU510B250VM		K-KDU572KVE		KDU50R63 (35 - 60) KDU50R160 (71 - 140)			
		•						
					KHFP5MA35 (35) KHFP5N63 (50-60) KHFP5N160 (71-140)			
KDAJ25K140A		KDAP25A56A (35-50) KDAP25A71A (60-71) KDAP25A140A (100-140)						

- (10) Requires installation box for adapter PCB, refer to table for model code
- (11) This option cannot be combined with BYCQ140EG(F)/EGFB
- (12) Maximum 2 optional PCBs can be mounted
- (13) Applicable boxes (KJB*) to mount controllers can be found in the controls option list
- (14) Extension wire (EWHARI) is needed if both auto cleaning panel AND Onecta app are connected
- (15) Wire harness EKRS21 needed. Standard Wireless LAN needs to be turned off to use these controllers
- (16) The active airflow circulation function is not available for this controller
- (17) This option cannot be combined with Onecta app
- (18) Only possible in combination with wired or wireless remote control

- (19) For directly mounting the decoration panel on the unit, decoration panel option EKBYBSD is required.
- (20) This option cannot be combined with KRP4A51 and KRP2A51. (in case of filter, filter chamber is required)
- (21) Mounting plate KKSAP50A56 needed for 35-50 capacity class
- (22) Only possible in combination with BYCQ140E and BYCQ140EW. Cannot be combined with other filters, chambers, fresh air intake kits or air discharge outlet sealing member kit
- (23) Only possible in combination with BYCQ140E/EW/EB. Cannot be combined with other filters, chambers, fresh air intake kits or discharge outlet sealing member kit

Options - Sky Air

		R-32				
		RZAG-A	RZAG-NV1/NY1	RZASG-MV(1)/MY(1)	RZA-D	AZAS-MV/MY
Refrigerant branch piping (3)	for twin		KHRQ58T (imperial size)	KHRQ58T (imperial size)	KHRQ22M20TA (imperial size)	
	for triple		KHRQ58H (imperial size)	KHRQ58H (100 - 140) (imperial size)	KHRQ250H7 (imperial size)	
	for double twin		KHRQ58T (3x) (125 - 140) (imperial size)	KHRQ58T (3x) (125 - 140) (imperial size)	KHRQ22M20TA (x3) (imperial size)	
	Asymmetric combinations piping reducer	ASYCPIR (see table below)				
Demand adapter kit			SB.KRP58M52 (1)	SB.KRP58M52 (1)	KRP58M51 (2)	
Bottom plate heater - To keep drain holes ice-free in extreme weather conditions			EKBPH140N		EKBPH250D	
Sound enclosure			EKLN140A		EKLN140A	

- (1) Contains KRP58M1 and obligatory mounting kit EKMKSA2
 (2) To mount KRP58M51, an additional mounting kit (EKMKSA3) needs to be used (obligatory)
 (3) For metric size refrigerant branching contact your local sales representative

EKLN140A - Sound enclosure

Drain pan	EKLN140-DP
Drain pan heater tape	EKLN140-DPHT (1)

(1) Only in combination with EKLN140-DP

Option for asymmetric combination (Asymmetric combinations piping reducer)

ASYCPIR		Liquid	GAS	
		ø 9.52 → ø 6.4	ø 12.7 → ø 9.52	ø 15.9 → ø 12.7
RZAG35A	FDXM50F9		•	
	FFA50A9		•	
	FBA50A9		•	
	FCAG50B		•	
	FNA50A9		•	
	FTXM50R		•	
	FHA50A9		•	
RZAG60A	FBA71A9	•		
	FCAG71B	•		•
	FTXM71R			•
	FHA71A9	•		•

Example of using:

1) Connecting a pipe of ø12.7 to a gas pipe connection port for ø15.9:

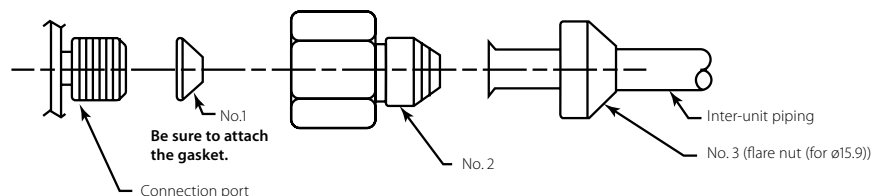

Options - Rooftop

Field applied accessories for Made-To-Stock units

		BASE series (UATYA-BBAY1)				FC2 series (UATYA-BFC2Y1)					FC3 series (UATYA-BFC3Y1)									
		25-30	40-50	60-70	80-120	140-190	25-30	40-50	60-70	80-90	100-120	140-190	25-30	40-50	60-70	80-100	110-120	140-180	190	
Air treatment	Filter ISO Coarse 75% (G4)	2x UATYAC75A + 2x UATYAC75B (Standard for MTS)	3x UATYAC75A + 3x UATYAC75B (Standard for MTS)	6x UATYAC75B (Standard for MTS)	12x UATYAC75C (Standard for MTS)	12x UATYAC75C (Standard for MTS)	2x UATYAC75A + 2x UATYAC75B (Standard for MTS)	3x UATYAC75A + 3x UATYAC75B (Standard for MTS)	6x UATYAC75B (Standard for MTS)	12x UATYAC75C (Standard for MTS)	12x UATYAC75C (Standard for MTS)	12x UATYAC75C (Standard for MTS)	2x UATYAC75A + 2x UATYAC75B (Standard for MTS)	3x UATYAC75A + 3x UATYAC75B (Standard for MTS)	6x UATYAC75B (Standard for MTS)	12x UATYAC75C (Standard for MTS)	12x UATYAC75C (Standard for MTS)	12x UATYAC75C (Standard for MTS)	12x UATYAC75C (Standard for MTS)	
	Filter ISO ePM10 50% (MS/FS)	2x UATYAEPM1050A + 2x UATYAEPM1050B	3x UATYAEPM1050A + 3x UATYAEPM1050B	3x UATYAEPM1050B	12x UATYAEPM1050C	12x UATYAEPM1050C	2x UATYAEPM1050A + 2x UATYAEPM1050B	3x UATYAEPM1050A + 3x UATYAEPM1050B	3x UATYAEPM1050B	12x UATYAEPM1050C	12x UATYAEPM1050C	12x UATYAEPM1050C	2x UATYAEPM1050A + 2x UATYAEPM1050B	3x UATYAEPM1050A + 3x UATYAEPM1050B	3x UATYAEPM1050B	12x UATYAEPM1050C	12x UATYAEPM1050C	12x UATYAEPM1050C	12x UATYAEPM1050C	
	Filter ISO ePM10 75% (M6)	2x UATYAEPM1075PA + 2x UATYAEPM1075PB	3x UATYAEPM1075PA + 3x UATYAEPM1075PB	3x UATYAEPM1075PB	12x UATYAEPM1075PC	12x UATYAEPM1075PC	2x UATYAEPM1075PA + 2x UATYAEPM1075PB	3x UATYAEPM1075PA + 3x UATYAEPM1075PB	3x UATYAEPM1075PB	12x UATYAEPM1075PC	12x UATYAEPM1075PC	12x UATYAEPM1075PC	2x UATYAEPM1075PA + 2x UATYAEPM1075PB	3x UATYAEPM1075PA + 3x UATYAEPM1075PB	3x UATYAEPM1075PB	12x UATYAEPM1075PC	12x UATYAEPM1075PC	12x UATYAEPM1075PC	12x UATYAEPM1075PC	
	Filter ISO ePM1 50% (F7)	2x UATYAEPM150PA + 2x UATYAEPM150PB	3x UATYAEPM150PA + 3x UATYAEPM150PB	3x UATYAEPM150PB	12x UATYAEPM150PC	12x UATYAEPM150PC	2x UATYAEPM150PA + 2x UATYAEPM150PB	3x UATYAEPM150PA + 3x UATYAEPM150PB	3x UATYAEPM150PB	12x UATYAEPM150PC	12x UATYAEPM150PC	12x UATYAEPM150PC	2x UATYAEPM150PA + 2x UATYAEPM150PB	3x UATYAEPM150PA + 3x UATYAEPM150PB	3x UATYAEPM150PB	12x UATYAEPM150PC	12x UATYAEPM150PC	12x UATYAEPM150PC	12x UATYAEPM150PC	
	Rigid bag filter ISO ePM10 70% (M6)	2x UATYAEPM1070A + 2x UATYAEPM1070B	3x UATYAEPM1070A + 3x UATYAEPM1070B	6x UATYAEPM1070B	12x UATYAEPM1070C	12x UATYAEPM1070C	2x UATYAEPM1070A + 2x UATYAEPM1070B	3x UATYAEPM1070A + 3x UATYAEPM1070B	6x UATYAEPM1070B	12x UATYAEPM1070C	12x UATYAEPM1070C	12x UATYAEPM1070C	2x UATYAEPM1070A + 2x UATYAEPM1070B	3x UATYAEPM1070A + 3x UATYAEPM1070B	6x UATYAEPM1070B	12x UATYAEPM1070C	12x UATYAEPM1070C	12x UATYAEPM1070C	12x UATYAEPM1070C	
	Rigid bag filter ISO ePM1 50% (F7)	2x UATYAEPM150A + 2x UATYAEPM150B	3x UATYAEPM150A + 3x UATYAEPM150B	6x UATYAEPM150B	12x UATYAEPM150C	12x UATYAEPM150C	2x UATYAEPM150A + 2x UATYAEPM150B	3x UATYAEPM150A + 3x UATYAEPM150B	6x UATYAEPM150B	12x UATYAEPM150C	12x UATYAEPM150C	12x UATYAEPM150C	2x UATYAEPM150A + 2x UATYAEPM150B	3x UATYAEPM150A + 3x UATYAEPM150B	6x UATYAEPM150B	12x UATYAEPM150C	12x UATYAEPM150C	12x UATYAEPM150C	12x UATYAEPM150C	
	Rigid bag filter ISO ePM1 85% (F9)	2x UATYAEPM185A + 2x UATYAEPM185B	3x UATYAEPM185A + 3x UATYAEPM185B	6x UATYAEPM185B	12x UATYAEPM185C	12x UATYAEPM185C	2x UATYAEPM185A + 2x UATYAEPM185B	3x UATYAEPM185A + 3x UATYAEPM185B	6x UATYAEPM185B	12x UATYAEPM185C	12x UATYAEPM185C	12x UATYAEPM185C	2x UATYAEPM185A + 2x UATYAEPM185B	3x UATYAEPM185A + 3x UATYAEPM185B	6x UATYAEPM185B	12x UATYAEPM185C	12x UATYAEPM185C	12x UATYAEPM185C	12x UATYAEPM185C	
	Control	UATYAC02P - Duct air quality CO ₂ probe	•	•	•	•	•	•	•	•	•	•	•	•	•	•	•	•	•	•
		UATYACAP - Constant air pressure control airflow transducer	•	•	•	•	•	•	•	•	•	•	•	•	•	•	•	•	•	•
UATYAWRC - Remote touch screen wired remote controller		•	•	•	•	•	•	•	•	•	•	•	•	•	•	•	•	•	•	
UATYARRP - Room temperature return probe (incl. housing)		•	•	•	•	•	•	•	•	•	•	•	•	•	•	•	•	•	•	
UATYASA - Fire and smoke alarm		•	•	•	•	•	•	•	•	•	•	•	•	•	•	•	•	•	•	
Other	Rainproof hood with anti-intrusion grille	not possible	not possible	not possible	not possible	not possible	UATYARPH3	UATYARPH4	UATYARPH5	UATYARPH6	UATYARPH6	UATYARPH6	UATYARPH6	UATYARPH6	UATYARPH6	UATYARPH7	UATYARPH7	UATYARPH7	UATYARPH7	
	Rubber antivibration mounts	2x UATYAAVM1	2x UATYAAVM1	2x UATYAAVM1 + 1x UATYAAVM2	4x UATYAAVM1	2x UATYAAVM1 + 2x UATYAAVM2	2x UATYAAVM1	2x UATYAAVM1	2x UATYAAVM1 + 1x UATYAAVM2	4x UATYAAVM1	3x UATYAAVM1 + 1x UATYAAVM2	2x UATYAAVM1 + 2x UATYAAVM2	1x UATYAAVM1 + 2x UATYAAVM2	3x UATYAAVM1 + 1x UATYAAVM2	3x UATYAAVM1 + 2x UATYAAVM2	2x UATYAAVM1 + 2x UATYAAVM2	2x UATYAAVM1 + 2x UATYAAVM2	4x UATYAAVM1 + 1x UATYAAVM2	3x UATYAAVM1 + 2x UATYAAVM2	
	Rubber antivibration mounts when gas heater is used	1x UATYAAVM1 + 1x UATYAAVM2	1x UATYAAVM1 + 1x UATYAAVM2	1x UATYAAVM1 + 2x UATYAAVM2	5x UATYAAVM1	2x UATYAAVM1	1x UATYAAVM1 + 1x UATYAAVM2	4x UATYAAVM1	5x UATYAAVM1	5x UATYAAVM1	5x UATYAAVM1	1x UATYAAVM1 + 1x UATYAAVM2	2x UATYAAVM1 + 1x UATYAAVM2	4x UATYAAVM1	5x UATYAAVM1	4x UATYAAVM1 + 1x UATYAAVM2	3x UATYAAVM1 + 2x UATYAAVM2	3x UATYAAVM1 + 2x UATYAAVM2		

Field applied accessories for Made-To-Order units

		MT0 - BASE series	MT0 - FC2 series	MT0 - FC3 series	MT0 - RS4 series
Control	UATYAC02P - Duct air quality CO ₂ probe	•	•	•	•
	UATYACAP - Constant air pressure control airflow transducer	•	•	•	•
	UATYAWRC - Remote touch screen wired remote controller	•	•	•	•
	UATYARRP - Room temperature return probe (incl. housing)	•	•	•	•
	UATYASA - Fire and smoke detector	•	•	•	•
Other	Rubber antivibration mounts	• (1)	• (1)	• (1)	• (1)
	Rainproof hood with anti-intrusion grille	• (1)	• (1)	• (1)	• (1)

(1) Reference code to be selected in selection software

Options - Ventilation

		Energy recovery ventilation - VAM					
		VAM 150FC9	VAM 250FC9	VAM 350J8	VAM 500J8	VAM 650J8	VAM 800J8
Individual control systems	BRC301B61 VAM wired remote control	•	•	•	•	•	•
	Madoka BRC1H52W (White) / BRC1H52S (Silver) / BRC1H52K (Black) User-friendly wired remote controller with premium design	•	•	•	•	•	•
	BRC1E53A/B/C Wired remote control with full-text interface and back-light	•	•	•	•	•	•
	BRC1D52 Standard wired remote control with weekly timer	•	•	•	•	•	•
Centralised control systems	DCC601A51 intelligent Tablet Controller	•	•	•	•	•	•
	DCS601C51 intelligent Touch Controller	•	•	•	•	•	•
	DCS302C51 Central remote control	•	•	•	•	•	•
	DCS301B51 Unified ON/OFF control	•	•	•	•	•	•
Building Management System & Standard protocol interface	DCM601A51 intelligent Touch Manager	•	•	•	•	•	•
	EKMBDXB Modbus interface	•	•	•	•	•	•
	DMS502A51 BACnet Interface	•	•	•	•	•	•
	DMS504B51 LonWorks Interface	•	•	•	•	•	•
Filters	Coarse 55% (G4)						
	ePM10 75% (M5)						
	ePM10 70% (M6)			EKAFVJ50F6	EKAFVJ50F6	EKAFVJ65F6	EKAFVJ100F6
	ePM1 50% (F7)						
	ePM1 60% (F7)			EKAFVJ50F7	EKAFVJ50F7	EKAFVJ65F7	EKAFVJ100F7
	ePM ₁ 70% (F8)			EKAFVJ50F8	EKAFVJ50F8	EKAFVJ65F8	EKAFVJ100F8
	ePM1 80% (F9)						
	High efficiency filter						
Replacement air filter							
Mechanical accessories	Rail						
	Rectangular to round duct transition						
	Separate plenum						
CO ₂ sensor				BRYMA65	BRYMA65	BRYMA65	BRYMA100
Electrical heater for pre treatment of fresh air		GSIEKA10009	GSIEKA15018	GSIEKA20024	GSIEKA20024	GSIEKA25030	GSIEKA25030
DX coil for post treatment of fresh air					EKVDX32A	EKVDX50A	EKVDX50A
Silencer (900mm depth)							
Electrical accessories	Wiring adapter for external monitoring/control (controls 1 entire system)	KRP2A51 (2)	KRP2A51 (2)	KRP2A51 (2)	KRP2A51 (2)	KRP2A51 (2)	KRP2A51 (2)
	Adapter PCB for humidifier						
	Adapter PCB for third party heater	BRP4A50A	BRP4A50A	BRP4A50A (4)	BRP4A50A (4)	BRP4A50A (3/4)	BRP4A50A (4)
	External wired temperature sensor						
	Adapter PCB Mounting plate	EKMP25VAM	EKMP25VAM			EKMP65VAM	
	Installation box for adaptor PCB	KRP1BB101	KRP1BB101	KRP1BB101	KRP1BB101	KRP1BB101	KRP1BB101

Notes

- (1) Do not connect the system to DIII-net devices LONWorks interface, BACnet interface, ...; (intelligent Touch Manager, EKMBDXA are allowed)
- (2) Installation box needed
- (3) Adapter PCB mounting plate needed, applicable model can be found in the table above
- (4) 3rd party heater and 3rd party humidifier cannot be combined
- (5) Contains 1 plenum and can be used for half side of the unit (up to 4 plenums can be used on 1 unit)
- (6) Available only with optional plenum

			Air handling unit applications		
VAM 1000J8	VAM 1500J8	VAM 2000J8	EKEQFCBA (1)	EKEQDCB (1)	EKEQMCBA (1)
•	•	•			
•	•	•	•	•	•
•	•	•	•	•	•
•	•	•	•	•	•
•	•	•	•	•	•
•	•	•	•	•	•
•	•	•			
•	•	•			
•	•	•	•	•	•
•	•	•	•	•	•
•	•	•			
•	•	•			
•	•	•	•	•	•
•	•	•			
•	•	•			
•	•	•			
•	•	•			
•	•	•			
EKAFVJ100F6	EKAFVJ100F6 x2	EKAFVJ100F6 x2			
EKAFVJ100F7	EKAFVJ100F7 x2	EKAFVJ100F7 x2			
EKAFVJ100F8	EKAFVJ100F8 x2	EKAFVJ100F8 x2			
	EKPLEN200 (5)	EKPLEN200 (5)			
BRYMA100	BRYMA200	BRYMA200			
GSIEKA25030	GSIEKA35530 (6)				
EKVDX80A	EKVDX100A	EKVDX100A			
KRP2A51 (2)	KRP2A51 (2)	KRP2A51 (2)			
BRP4A50A (4)	BRP4A50A (3/4)	BRP4A50A (3/4)			
				KRCS01-1	
	EKMPVAM				
KRP1BB101	KRP1BB101	KRP1BB101			

Options - Ventilation

Accessories	Modular L Pro						Modular T Pro				
	ALB02LB ALB02RB	ALB03LB ALB03RB	ALB04LB ALB04RB	ALB05LB ALB05RB	ALB06LB ALB06RB	ALB07LB ALB07RB	ATB03RA ATB03LA	ATB04RA ATB04LA	ATB05RA ATB05LA	ATB06RA ATB06LA	ATB07RA ATB07LA
Iso Coarse 55% (G4) Filter	ALF02G4A	ALF03G4A	ALF05G4A		ALF07G4A		ATF03G4A	ATF04G4A	ATF05G4A	ATF06G4A	ATF07G4A
ePM10 75% (M5) Filter	ALF02M5A	ALF03M5A	ALF05M5A		ALF07M5A		ATF03M5A	ATF04M5A	ATF05M5A	ATF06M5A	ATF07M5A
ePM1 50% (F7) Filter	ALF02F7A	ALF03F7A	ALF05F7A		ALF07F7A		ATF03F7A	ATF04F7A	ATF05F7A	ATF06F7A	ATF07F7A
ePM1 80% (F9) Filter	ALF02F9A	ALF03F9A	ALF05F9A		ALF07F9A		ATF03F9A	ATF04F9A	ATF05F9A	ATF06F9A	ATF07F9A
Sound attenuator	ALS0290A	ALS0390A	ALS0590A		ALS0790A		ATS0360A	ATS0460A	ATS0560A	ATS0660A	ATS0760A
Rails for door	ALA02RLA	ALA03RLA	ALA05RLA		ALA07RLA						
Duct transition	ALA02RCA	ALA03RCA	ALA05RCA		ALA07RCA						
Mixing damper							ATA03MDA	ATA04MDA	ATA05MDA	ATA06MDA	ATA07MDA
External damper							ATA03EDA	ATA04EDA	ATA05EDA	ATA06EDA	ATA07EDA
Electric pre heater ¹	ALD02HEFA	ALD03HEFA	ALD05HEFA		ALD07HEFA		ATD03HEFAU	ATD04HEFAU	ATD05HEFAU	ATD06HEFAU	ATD07HEFAU
Electric post heater ¹	ALD02HESA	ALD03HESA	ALD05HESA		ALD07HESA		ATD03HESAU	ATD04HESAU	ATD05HESAU	ATD06HESAU	ATD07HESAU
DX coil ²							ATD03UDSAR	ATD04UDSAR	ATD05UDSAR	ATD06UDSAR	ATD07UDSAR
							ATD03UDSAL	ATD04UDSAL	ATD05UDSAL	ATD06UDSAL	ATD07UDSAL
WATER coil ²	ALD02CWSA	ALD03CWSA	ALD05CWSA		ALD07CWSA		ATD03UWSAR	ATD04UWSAR	ATD05UWSAR	ATD06UWSAR	ATD07UWSAR
							ATD03UWSAL	ATD04UWSAL	ATD05UWSAL	ATD06UWSAL	ATD07UWSAL
Water pre heating coil	ALD02HWUA	ALD03HWUA	ALD05HWUA		ALD07HWUA		ATD03HWFUA	ATD04HWFUA	ATD05HWFUA	ATD06HWFUA	ATD07HWFUA
Water post heating coil ²	ALD02HWUA	ALD03HWUA	ALD05HWUA		ALD07HWUA		ATD03HWSAR	ATD04HWSAR	ATD05HWSAR	ATD06HWSAR	ATD07HWSAR
							ATD03HWSAL	ATD04HWSAL	ATD05HWSAL	ATD06HWSAL	ATD07HWSAL
Water valve 2 way cooling	ALV02CW2A	ALV03CW2A	ALV05CW2A		ALV07CW2A		ATV03CW2A	ATV04CW2A	ATV05CW2A	ATV06CW2A	ATV07CW2A
Water valve 2 way heating	ALV02HW2A	ALV03HW2A	ALV05HW2A		ALV07HW2A		ATV03HW2A	ATV04HW2A	ATV05HW2A	ATV06HW2A	ATV07HW2A
Water valve 3 way cooling	ALV02CW3A	ALV03CW3A	ALV05CW3A		ALV07CW3A		ATV03CW3A	ATV04CW3A	ATV05CW3A	ATV06CW3A	ATV07CW3A
Water valve 3 way heating	ALV02HW3A	ALV03HW3A	ALV05HW3A		ALV07HW3A		ATV03HW3A	ATV04HW3A	ATV05HW3A	ATV06HW3A	ATV07HW3A
Valve modulating actuator			ALE00AMVA						ATE00AMVA		
Damper modulating actuator									ATE00AMDA		
Digital PCB									ATE00DPUA		
Frost switch									ATE00FSUA		
CO ₂ sensor							ALP00COA				
Humidity sensor							ALP00HUA				
Temperature probe							ALP00TEA				
Room Interface							ALC00822A (POL 822)				
Commissioning module							ALC00895A (POL 895)				
Modbus RTU module							ALC00902A (POL 902)				
Bacnet IP module							ALC00908A (POL 908)				
LonWorks Interface											
Intelligent Touch Manager											
Intelligent Tablet Controller											
Intelligent Touch Controller											
Central remote control											
Unified ON/OFF control											

Notes

- (1) For modular T pro only, both electric heater can be used as pre and post heater
- (2) For modular T pro only, sixth digit on main unit material name has to be aligned with last digit of the coil material name
 ATB0*RA --> ATD00*UDSAR
 ATB0*LA --> ATD00*UDSAL
 ATB0*RA --> ATD00*UWSAR
 ATB0*LA --> ATD00*UWSAL
 ATB0*RA --> ATD00*HWSAR
 ATB0*LA --> ATD00*HWSAL
- (3) Please refer to the selection software for more details on accessories and their incompatibilities.

Options - Control systems

Individual and centralised controls

	BRC1D*	BRC1E*	BRC1H*	DCS301B51	DST301B51	DCS302C51	DCS601C51
Madoka Assistant app for advanced settings			•				
Electrical box KJB111A	•	•	•				
Electrical box KJB212A(A) (1)	•	•		•	•		
Electrical box KJB311A(A)						•	
Electrical box KJB411AA							•

(1) recommended as wider (more stable mounting)

Intelligent Tablet Controller - DCC601A51

		intelligent Controller
		Options for local control
Wired screen for local control	AL-CCD07-VESA-1	•
Commissioning tool		•
Software update tool		•

Standard protocol interfaces - DMS502A51

		BACnet Interface
DIII-net expansion board (2 ports), connects up to 128 additional indoor units	DAM411B51	•
Digital pulse inputs (12) for PPD functionality	DAM412B51	•

Intelligent Touch Manager - DCM601B51

		Intelligent Manager	Daikin Cloud Service options (2)
DIII Plus Adaptor - Allows connection of additional 64 indoor units/groups. Only one adaptor can be connected (for more units, use DIII Plus Adaptor Slots)	DGE601A52	•	
DIII Plus Adaptor - Allows connection of additional 64 indoor units/groups. Up to 6 Adaptor Slots can be added to a DIII Plus Adaptor	DGE601A53		
iTM plus adaptor – Allows connection of an additional 64 indoor units/groups. Up to 7 adaptors can be connected	DCM601A52	•	
iTM PPD software – Allows distribution of used kWh by indoor units connected to the iTM	DCM002A51	•	
iTM HTTP interface - Allows communication to any third party controller via http interface	DCM007A51	•	
iTM Energy navigator – Energy management option	DCM008A51	•	
iTM BACnet Client option – Enables integration of third party devices to the iTM via the BACnet/IP protocol. (This is not a gateway and cannot replace DMS502A51)	DCM009A51	•	
Property Management System (PMS) interface option - Enables to connect to third party PMS systems	DCM010A51	• Oracle Opera PMS	
Monitoring package			•
Remote support and diagnostics package			•
Advise and optimisation package			•

WAGO interface options for intelligent Touch Manager

Required or optional WAGO base modules

Module type	Model code	Specifications	
24 V DC power supply	787-712	100 to 240 V AC → 24 V DC, 2.5 A	Required
Communications unit (Bus coupler)	WGDCMCPLR2	RS-485, Max:115.2kbps, not programmable	Required
Connector (1)	750-960		Required
Terminator module	750-600		Required
Power supply module	750-613	IN: 24 V DC, OUT: 5 V DC	Optional

Supported WAGO I/O modules

I/O module type	Model code	Specifications	N° of contacts
Di	750-400	No-voltage contact input	2
	750-432	Contact rating: 24 V DC / 4.5 mA*	4
	750-430	No-voltage contact input Contact rating: 24 V DC / 2.8 mA	8
Do	750-513/000-001	No-voltage contact output Contact rating: 230 V AC / 30 V DC, 2 A	2
	750-504	No-voltage contact output Contact rating: 24 V DC / 0.5 A	4
Ai	750-454	Rated at 4 to 20 mA: 12-bit resolution	2
	750-455		4
	750-479	Rated at -10 to 10 V: 13-bit resolution	2
	750-459	Rated at 0 to 10 V: 12-bit resolution	4
Ao	750-554	Rated at 4 to 20 mA: 12-bit resolution	2
	750-555		4
	750-560	Rated at -10 to 10 V: 10-bit resolution	2
	750-559	Rated at 0 to 10 V: 12-bit resolution	4
Thermistor	750-461/020-000	NTC20K thermistor	2
	750-461	Pt 100/RTD	2
	750-460		4
	750-461/000-003	Pt 1000/RTD	2
	750-460/000-003		4
	50-461/000-004	Ni 100/RTD	2
	750-461/000-005	Ni1000 TK6180/RTD	2
	750-460/000-005		4
Pi	750-638	Minimum pulse width: 1 ms	2

(1) This connector must be attached to a communications unit that is connected to the RS485 port (2-pin) of the iTM unit.

(2) To connect intelligent Touch Manager to the Daikin Cloud Service, the IoT gateway (EU.SB.5000072) and AC/DC converter (999175A) is needed.

We're here to help you! Online and offline

Online and offline VRV selection software



Business portal via mobile or desktop

my.daikin.eu

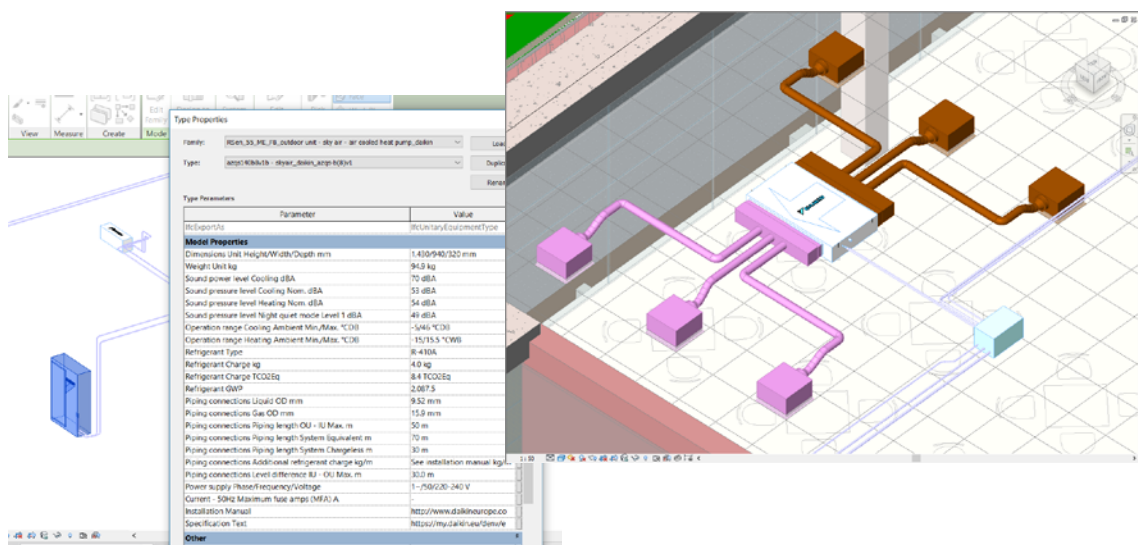

Full BIM object library available

bim.daikin.eu

Tools & platforms

All our commercial catalogues in one spot!
catalogues.daikin.eu

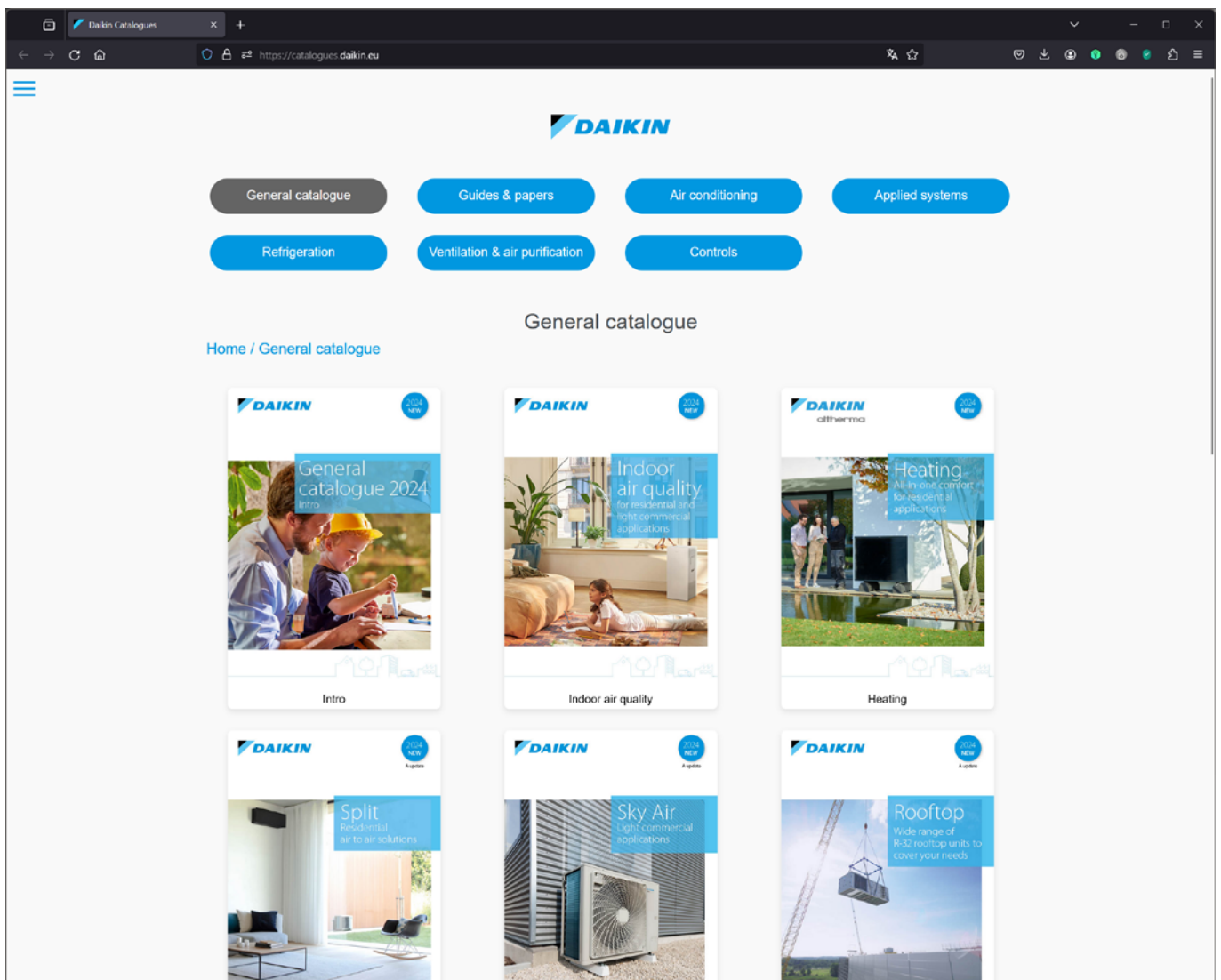

Ventilation selection software

Ventilation Xpress

Selection tool for ventilation devices (VAM, VKM). The selection is based on given supply/extract airflows (including fresh up and given ESP of supply/extract ducting):

- Determines size of electrical heaters
- Visualisation of psychrometric chart
- Visualisation of selected configuration
- Required field settings mentioned in the report

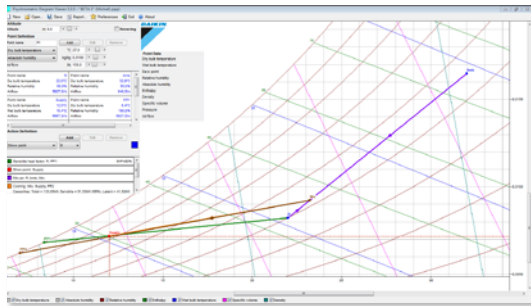

Webbased ASTRA selection for air handling units

A powerful tool to select the right Air Handling Units for your needs.

- 3D interface
- quick selection procedures
- new print-out possibilities and report shapes

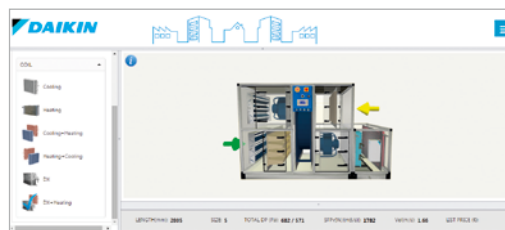

Plugins and third-party software tools

Building Information Modelling (BIM) support

- BIM improves efficiency of design and build phase
- Daikin is among the first to supply a full library of BIM objects for its VRV products

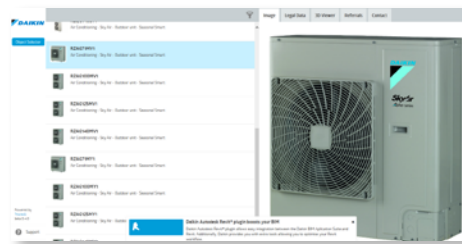

www.daikin.eu/bim

Energy simulation and design aid tools

Seasonal simulator

- The Seasonal Simulator is an innovative software tool that calculates and compares potential seasonal efficiency ratings.
- This user-friendly tool compares various Daikin systems, annual power consumption, CO₂ emissions, and much more, to present an accurate ROI calculation in a matter of minutes.



NEW Psychrometrics diagram

- The Psychrometrics Diagram Viewer demonstrates the changing properties of moist air.
- With this tool, users can choose two points with specific conditions, plot them on the diagram and select actions to change the conditions, i.e. heat, cool and mix air.

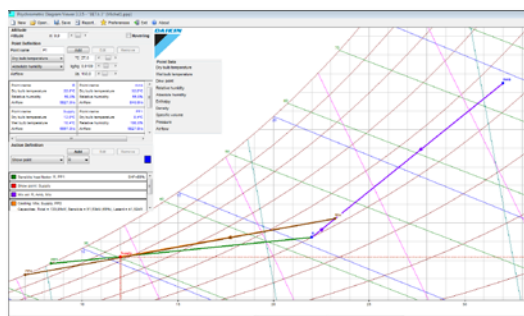

Software service tools

Error code app

Quickly know the meaning of fault codes, for each product family and the potential cause



D-Checker

D-checker is a software application used to record and monitor operation data of Daikin applied, split, Multi-split, Sky-air units, Daikin Altherma LT, ground source heat pump, Hybrid, ZEAS, Conveni-pack & R410A Booster unit

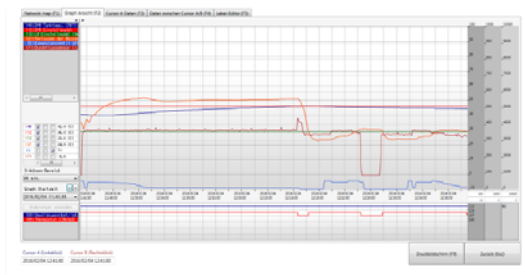

NEW Bluetooth adaptor

Monitoring of Split, Sky Air and VRV data via any bluetooth device

- No need to access the outdoor unit
 - Connects with D-Checker software (for laptops)
 - Connects with monitoring app (for tablets or smartphones)

Diagnosis of the Bluetooth system possible:



VRV Service-Checker

- Connected via F1/F2 bus to check multiple systems at the same time
- Connection of external pressure sensors possible

Online support

Business portal

- Experience our new extranet that thinks with you at my.daikin.eu
- Find information in seconds via a powerful search
- Customise the options so you see only info relevant for you
- Access via mobile device or desktop

my.daikin.eu



Internet

Find our solution for different applications:

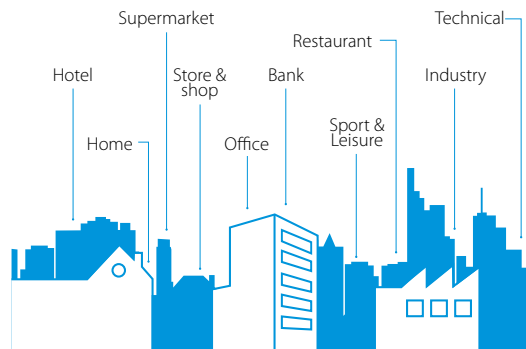

- Get more commercial details on our flagship products via our dedicated minisites
- See our references



Hotel Porta Fira

www.daikineurope.com/references

Europe's energy label

To enable consumers to compare and make purchasing decisions based on uniform labelling criteria, Europe has introduced energy labels. The previous European energy label for air conditioners, introduced in 1992, did its job for the time. In 2013, Europe introduced a seasonal energy label. This label allows end users to make even more informed choices, since seasonal efficiency reflects air conditioner efficiency over an entire season.

The energy label includes multiple classifications from A+++ to D, reflected in colour shadings ranging from dark green (most energy efficient) to red (least efficient). Information on the label not only includes the seasonal efficiency ratings for heating (SCOP) and cooling (SEER), but also annual energy consumption and noise levels.

The label more in detail

All energy efficiency classifications mentioned in this catalogue are within the range A+++ to D

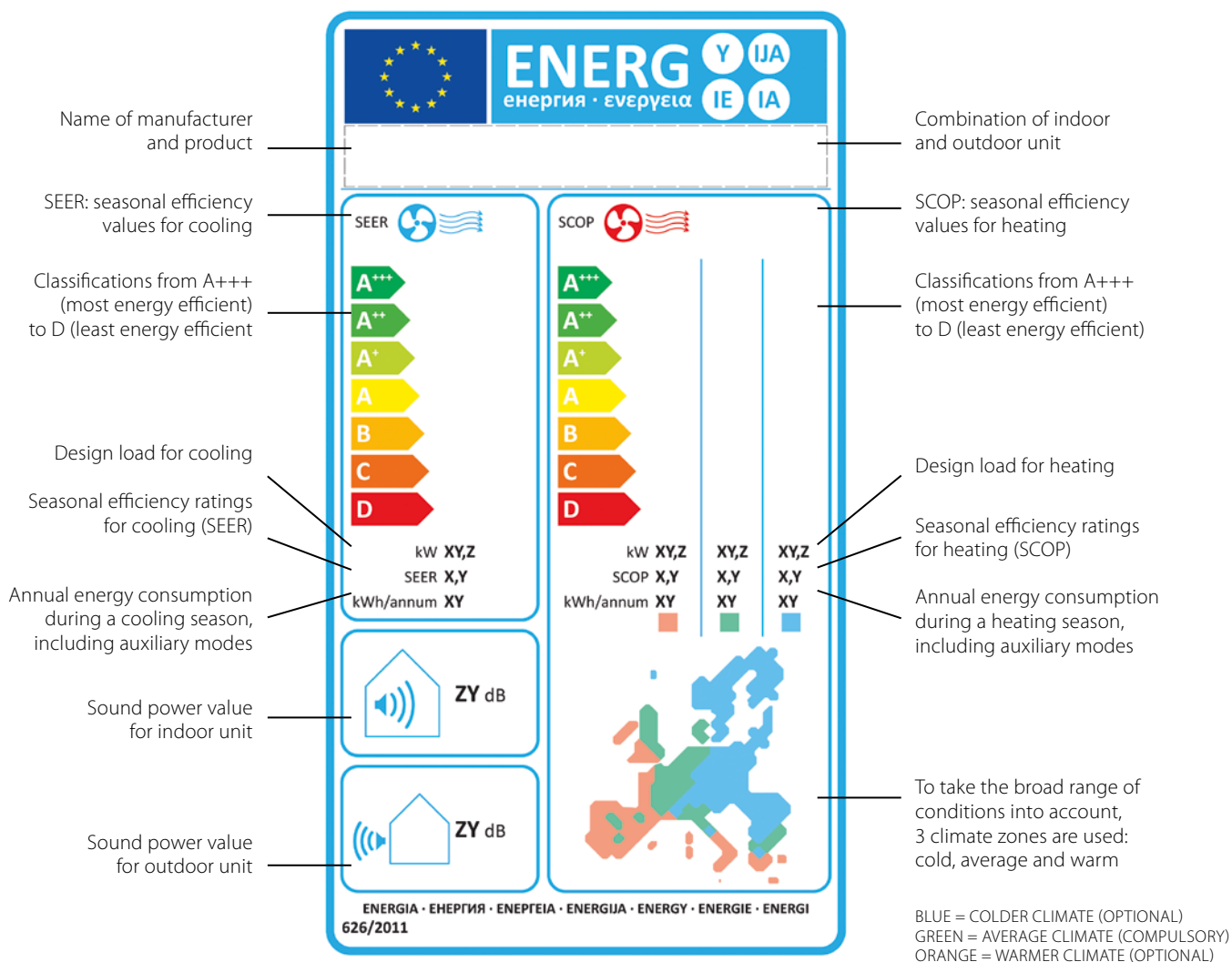

Measuring conditions

Power supply

T1 = 3~, 220V, 50Hz
 V1 = 1~, 220-240V, 50Hz
 VE = 1~, 220-240V/220V, 50Hz/60Hz*
 V3 = 1~, 230V, 50Hz
 VM = 1~, 220~240V/220~230V, 50Hz/60Hz
 W1 = 3N~, 400V, 50Hz
 Y1 = 3~, 400V, 50Hz

* For VE power supply only 1~, 220-240V, 50Hz data is displayed in this catalogue.

Conversion table refrigerant piping

inch	mm
1/4"	6.4 mm
3/8"	9.5 mm
1/2"	12.7 mm
5/8"	15.9 mm
3/4"	19.1 mm
7/8"	22.2 mm
1 1/8"	28.5 mm
1 3/8"	34.9 mm
1 5/8"	41.3 mm
1 3/4"	44.5 mm
2"	50.8 mm
2 1/8"	54 mm
2 5/8"	66.7 mm

F-gas regulation

For fully/partially charged equipment: contains fluorinated greenhouse gases. Actual refrigerant charge depends on the final unit construction, details can be found on the unit labels.

For non pre-charged equipment (Chillers: split chiller (SEHVX/SERHQ), condensing units and condenserless chillers + refrigeration (LCBKQ-AV1, JEHCCU/JEHSCU and ICU): Its functioning relies on fluorinated greenhouse gases.

Measuring conditions

Air conditioning

1) Nominal cooling capacities are based on:	
Indoor temperature	27°CDB/19°CWB
Outdoor temperature	35°CDB
Refrigerant piping length	7.5m - 8/5m VRV
Level difference	0m
2) Nominal heating capacities are based on:	
Indoor temperature	20°CDB
Outdoor temperature	7°CDB/6°CWB
Refrigerant piping length	7.5m - 8/5m VRV
Level difference	0m

The sound pressure level is measured via a microphone at a certain distance from the unit. It is a relative value, depending on the distance and acoustic environment (for measuring conditions: please refer to the technical databooks).

The sound power level is an absolute value indicating the "power" which a sound source generates.

For more detailed information please consult our technical databooks.



Technical drawings

Air flow patterns
available for
cassette units!



Indoor units	158
Outdoor units	196
Biddle air curtains	234
Ventilation units	237



Technical drawings

Indoor units

FCAG-B / FCAHG-H	159
FFA-A9	166
FDXM-F9	170
FBA-A(9)	173
FDA125A	178
FDA200-250A	179
ADEA-A	181
FAA-B	186
FHA-A(9)	188
FUA-A	191
FVA-A	192
FNA-A9	193



FCAG-B / FCAHG-H WITH STANDARD PANEL

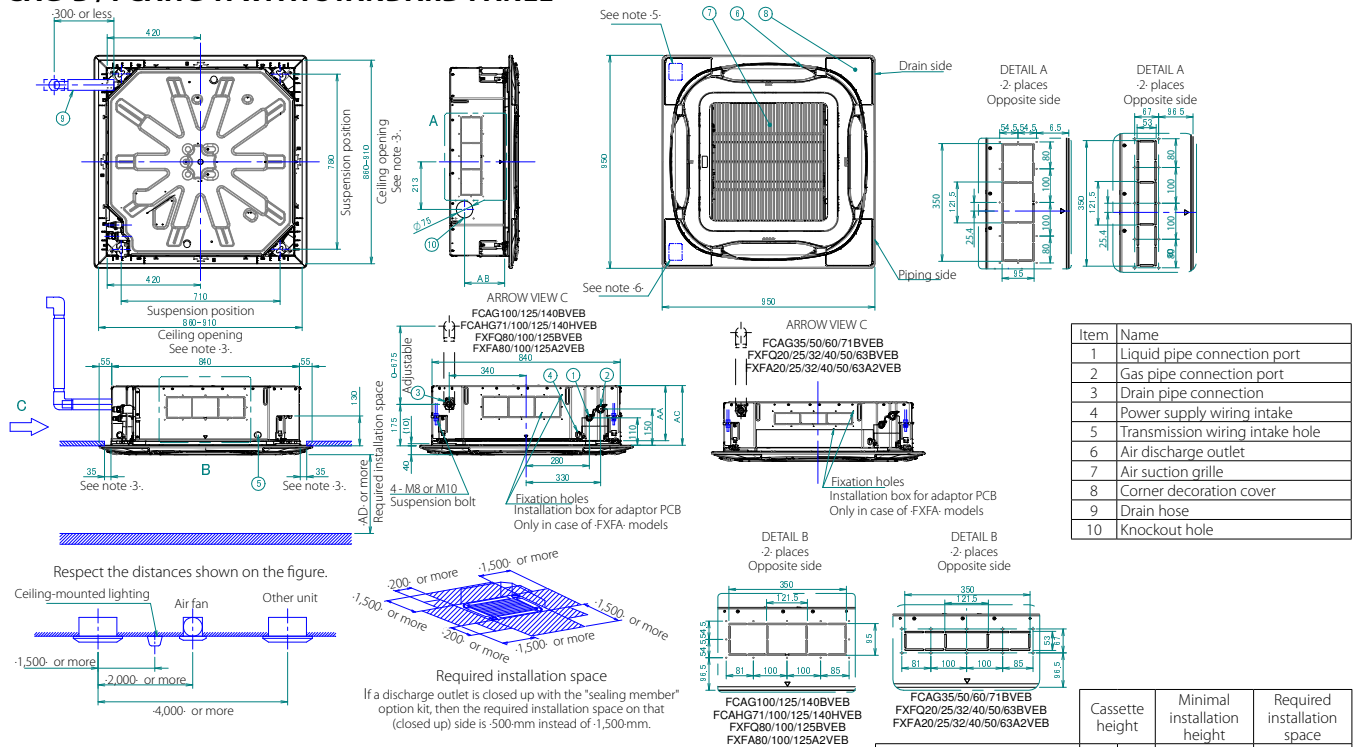

NOTES

- Location of nameplate
The unit nameplate is located on the control box cover.
The decoration panel nameplate is located on the piping-side panel frame, under the corner cover.
- When installing optional accessories, refer to their respective documentation.
- Make sure the distance between the ceiling and the cassette does not exceed 35 mm.
The maximum ceiling opening is 910 mm.
- When the conditions in the ceiling exceed 30°C ambient temperature and 80% relative humidity, or when fresh air is inducted into the ceiling, additional insulation is required (polyethylene foam, thickness ≥ 10 mm)
- When installing a sensor kit, there will be a sensor on this location. For details, see the drawing of the sensor kit.
- When installing a wireless controller, there will be a receiver on this location. For details, see the drawing of the wireless controller.

2D121655D

FCAG-B / FCAHG-H WITH AUTO CLEANING PANEL

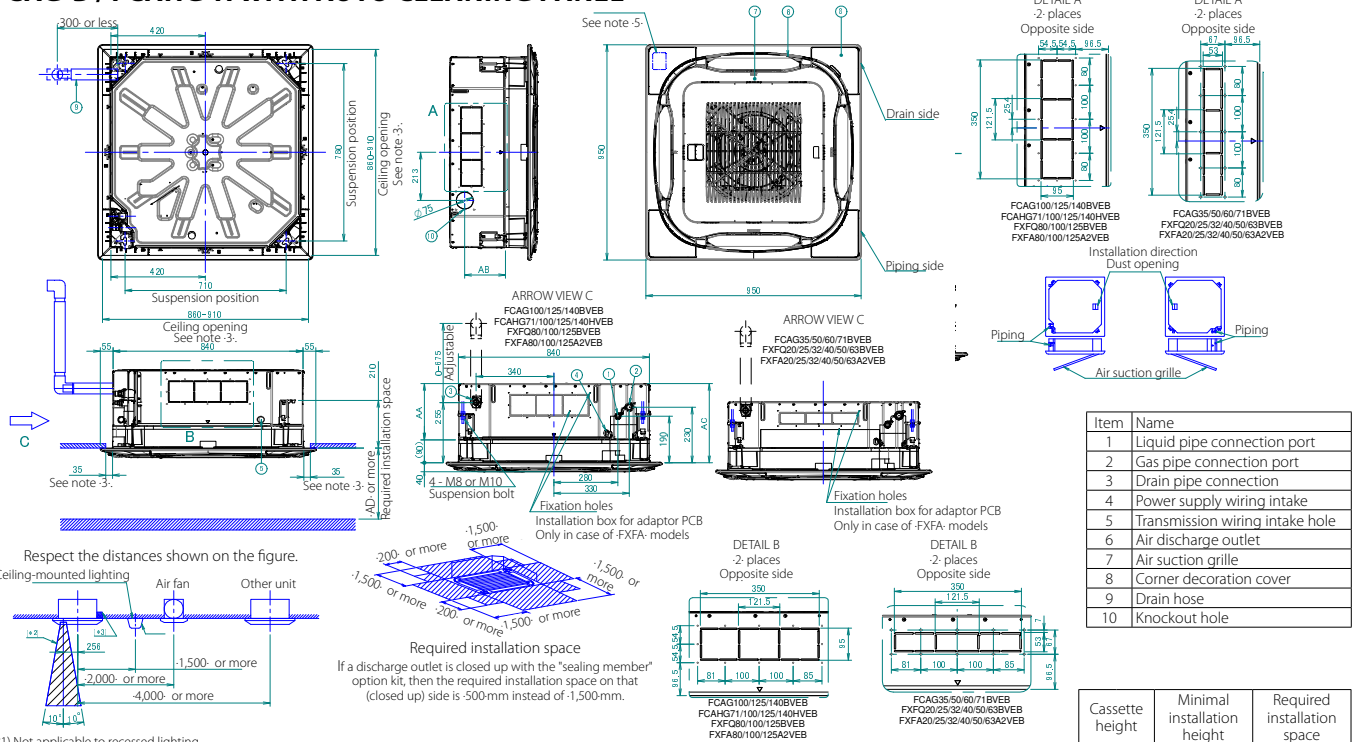

(*1) Not applicable to recessed lighting.

(*2) Required space for entering with vacuum cleaner tube.

(*3) Make sure the decoration panel discharge outlet is not blocked.

NOTES

- Location of nameplate
The unit nameplate is located on the control box cover.
The decoration panel nameplate is located on the piping-side panel frame, under the corner cover.
- When installing optional accessories, refer to their respective documentation.
- Make sure the distance between the ceiling and the cassette does not exceed 35 mm.
The maximum ceiling opening is 910 mm.
- When the conditions in the ceiling exceed 30°C ambient temperature and 80% relative humidity, or when fresh air is inducted into the ceiling, additional insulation is required (polyethylene foam, thickness ≥ 10 mm)
- When installing a sensor kit, there will be a sensor on this location. For details, see the drawing of the sensor kit.

2D121658D

DETAILED TECHNICAL DRAWINGS

FCAHG-B / FCAHG-H - DESIGNER PANEL

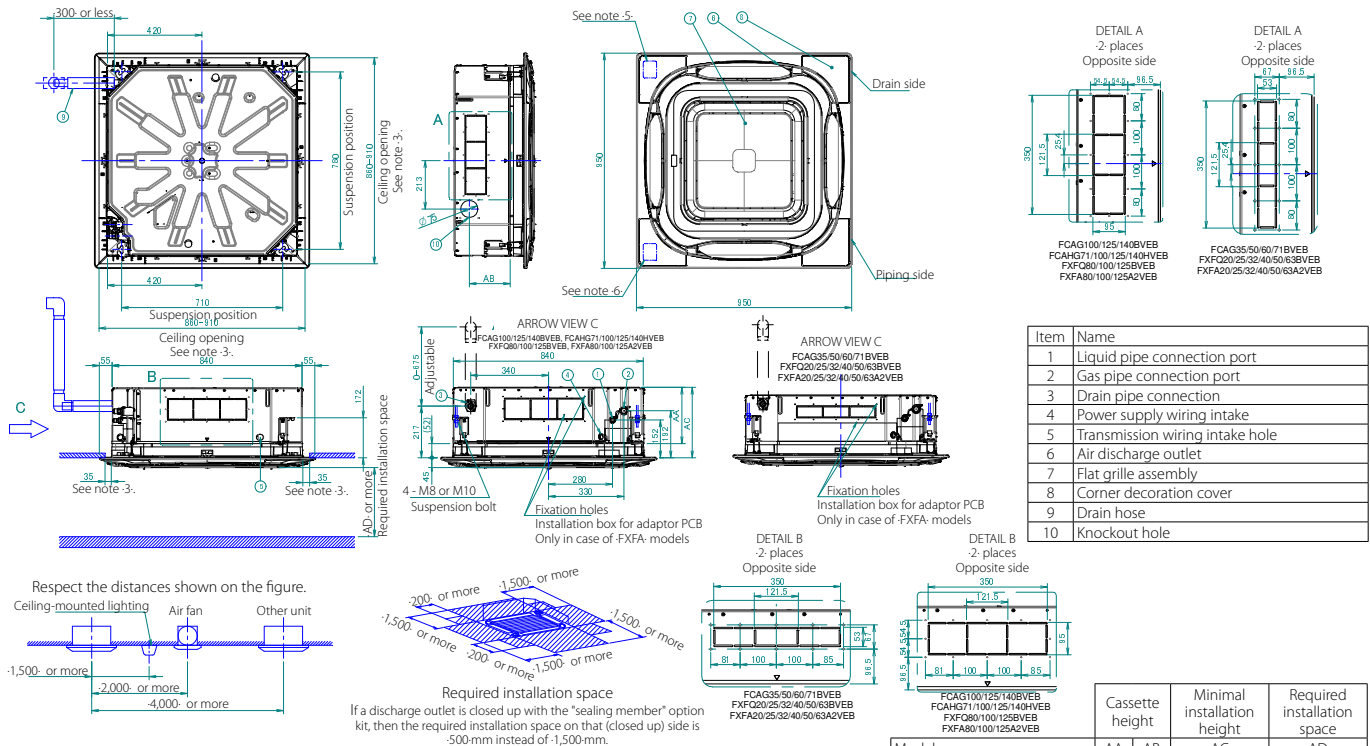

Item	Name
1	Liquid pipe connection port
2	Gas pipe connection port
3	Drain pipe connection
4	Power supply wiring intake
5	Transmission wiring intake hole
6	Air discharge outlet
7	Flat grille assembly
8	Corner decoration cover
9	Drain hose
10	Knockout hole

NOTES

- Location of nameplate
The unit nameplate is located on the control box cover.
The decoration panel nameplate is located on the piping-side panel frame, under the corner cover.
- When installing optional accessories, refer to their respective documentation.
- Make sure the distance between the ceiling and the cassette does not exceed 35 mm.
The maximum ceiling opening is 910 mm.
- When the conditions in the ceiling exceed 30°C ambient temperature and 80% relative humidity, or when fresh air is inducted into the ceiling, additional insulation is required (polyethylene foam, thickness ≥ 10 mm)
- When installing a sensor kit, there will be a sensor on this location. For details, see the drawing of the sensor kit.
- When installing a wireless controller, there will be a receiver on this location. For details, see the drawing of the wireless controller.

Model	Cassette height				Minimal installation height	Required installation space
	AA	AB	AC	AD		
FCAG35/50/60/71BVEB	204	139	269	2,700		
FCAG100/125/140BVEB	246	180	311	2,700		
FCAHG71/100/125/140HVEB	288	180	353	2,700		
FXFQ20/25/32/40/50/63BVEB	204	139	269	2,700		
FXFQ80/100BVEB	246	180	311	2,700		
FXFQ125BVEB	288	180	353	2,700		
FXFA20/25/32/40/50/63A2VEB	204	139	269	2,500		
FXFA80/100A2VEB	246	180	311	2,500		
FXFA125A2VEB	288	180	353	2,500		

2D121703D

FCAHG-B / FCAHG-H - FRESH AIR INTAKE

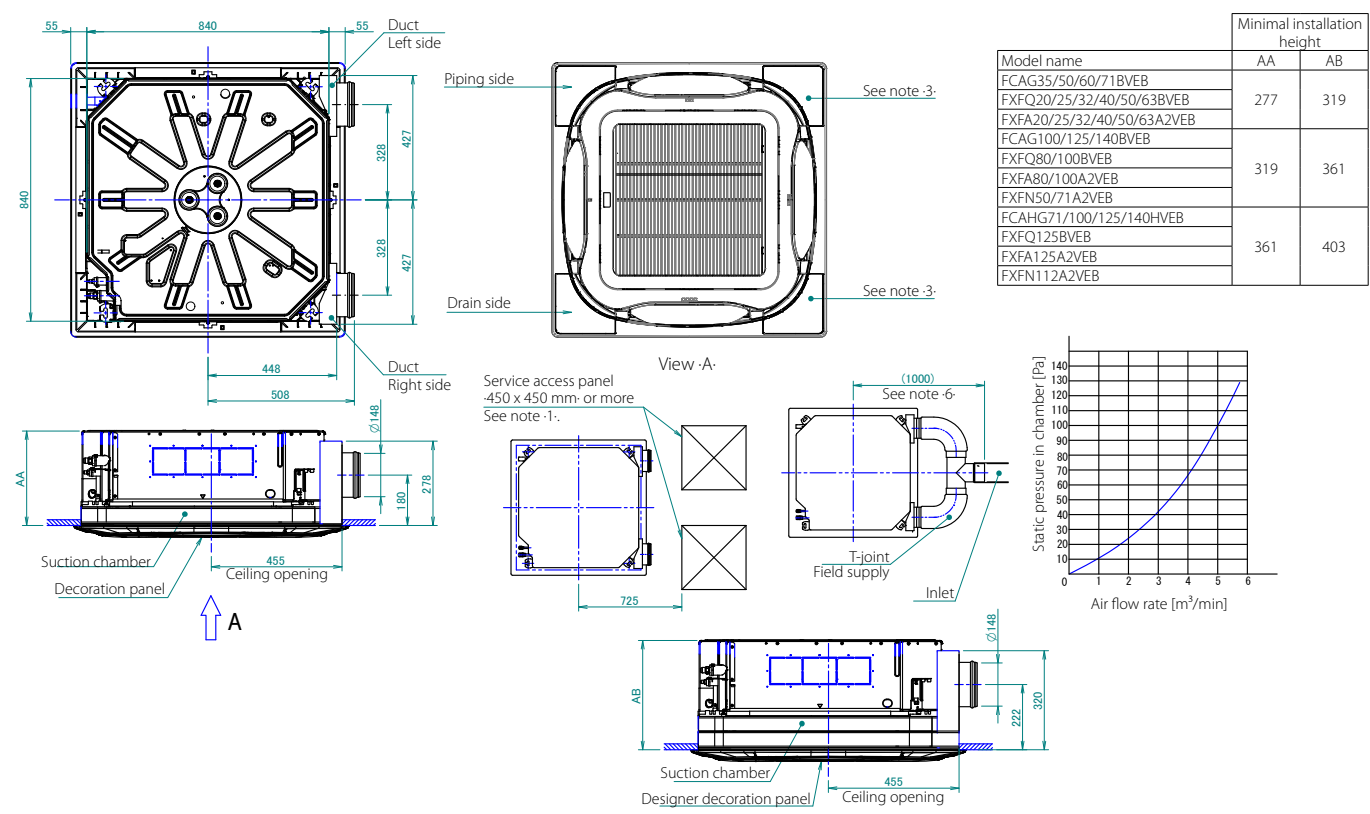

NOTES

- When installing a fresh air intake kit, provide a service access panel.
- Field construction
- This corner discharge outlet needs to be closed.
- When installing a duct fan, use a wiring adapter to link the duct fan to the fan of the indoor unit.
- The intake air flow rate is recommended to be ≤20% of the air flow rate at high fan speed.
If the intake air flow rate is too large, the operating sound may increase, and the detection of the indoor unit suction temperature may be affected.
- This indicates the distance between the T-joint inlet and the indoor unit inlet when the T-tube is connected.

3D121741C



FCAG35B

Air velocity distribution (cooling)

Air flow direction: horizontal
Air discharge: all-round

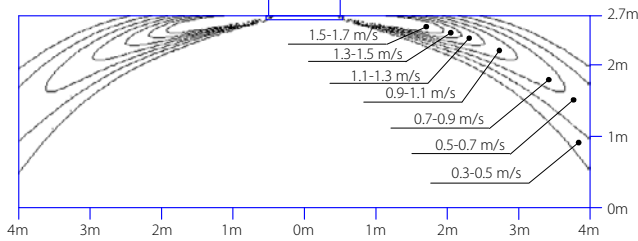

Air temperature distribution (cooling)

Air flow direction: horizontal
Air discharge: all-round

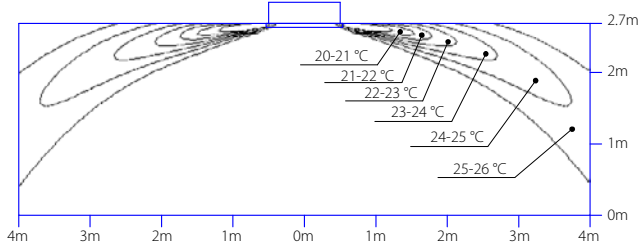

Air velocity distribution (heating)

Air flow direction: vertical
Air discharge: all-round

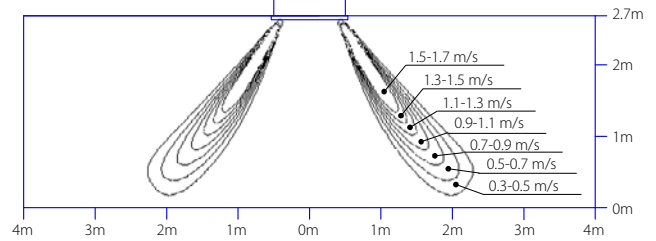

Air temperature distribution (heating)

Air flow direction: vertical
Air discharge: all-round

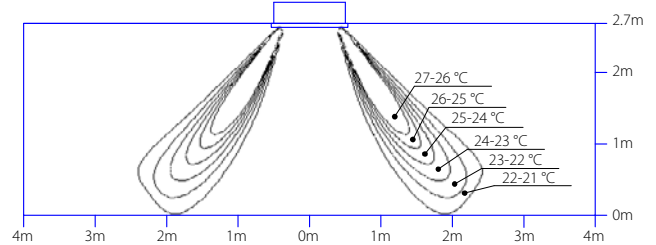

3D121618

FCAG50B

Air velocity distribution (cooling)

Air flow direction: horizontal
Air discharge: all-round

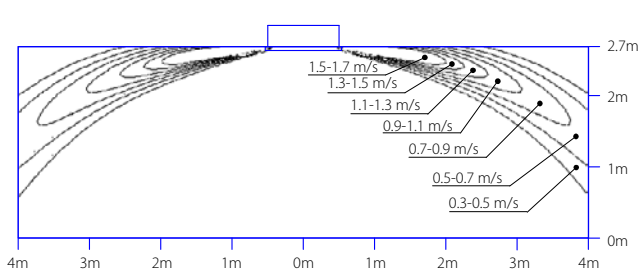

Air temperature distribution (cooling)

Air flow direction: horizontal
Air discharge: all-round

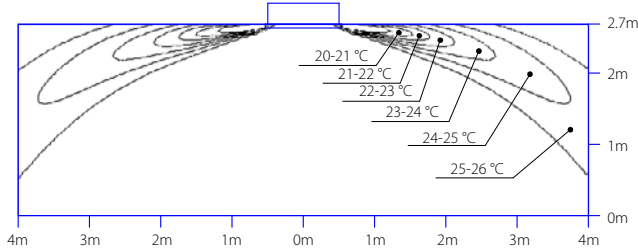

Air velocity distribution (heating)

Air flow direction: vertical
Air discharge: all-round

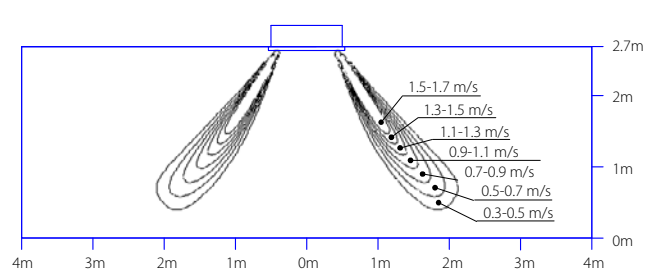

Air temperature distribution (heating)

Air flow direction: vertical
Air discharge: all-round

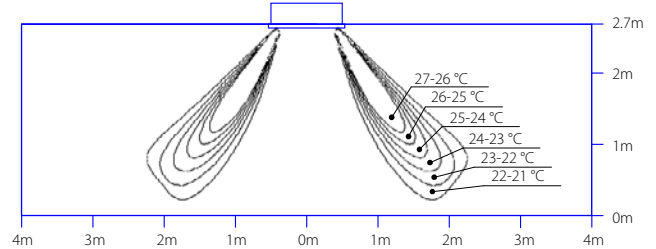

3D121619

FCAG60B

Air velocity distribution (cooling)

Air flow direction: horizontal
Air discharge: all-round

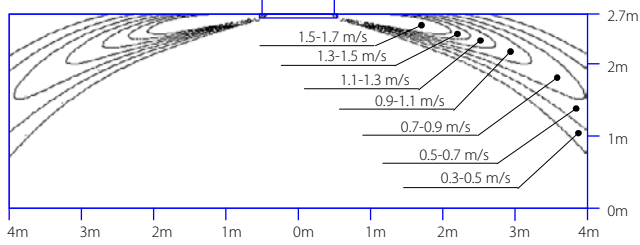

Air temperature distribution (cooling)

Air flow direction: horizontal
Air discharge: all-round

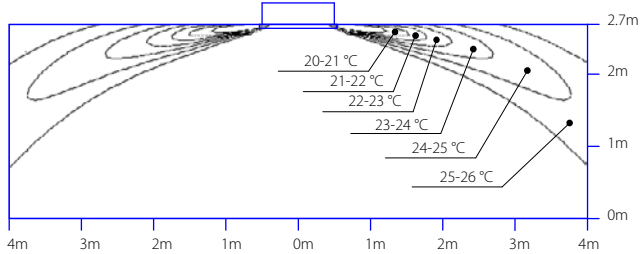

Air velocity distribution (heating)

Air flow direction: vertical
Air discharge: all-round

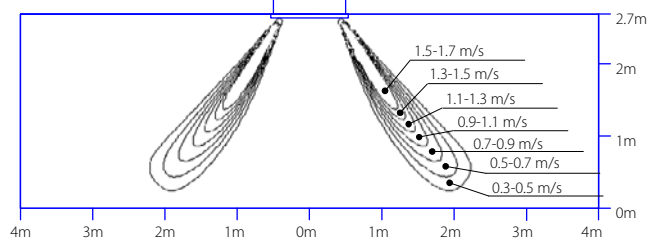

Air temperature distribution (heating)

Air flow direction: vertical
Air discharge: all-round

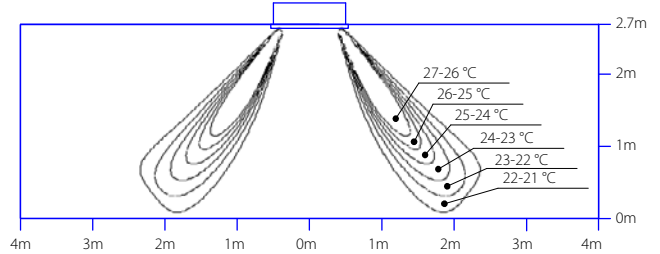

3D121620A

FCAG71B

Air velocity distribution (cooling)

Air flow direction: horizontal
Air discharge: all-round

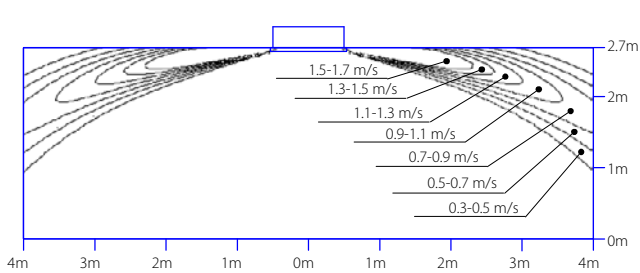

Air temperature distribution (cooling)

Air flow direction: horizontal
Air discharge: all-round

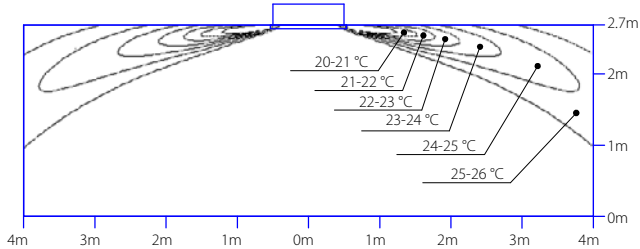

Air velocity distribution (heating)

Air flow direction: vertical
Air discharge: all-round

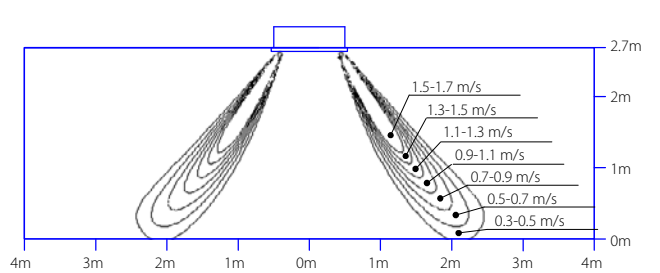

Air temperature distribution (heating)

Air flow direction: vertical
Air discharge: all-round

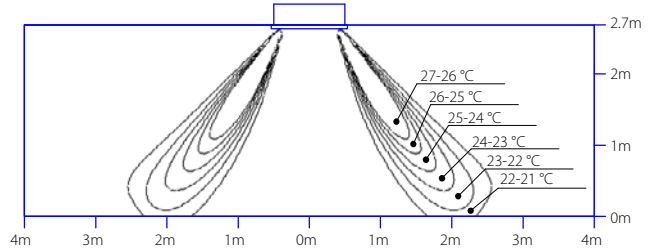

3D121621A



FCAG100B

Air velocity distribution (cooling)

Air flow direction: horizontal
Air discharge: all-round

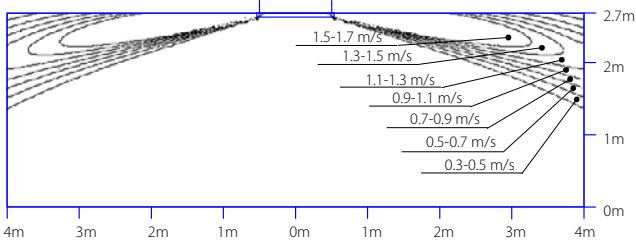

Air temperature distribution (cooling)

Air flow direction: horizontal
Air discharge: all-round

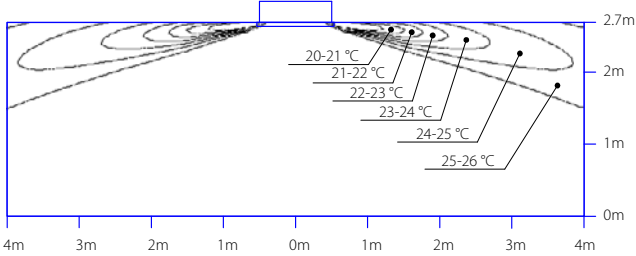

Air velocity distribution (heating)

Air flow direction: vertical
Air discharge: all-round

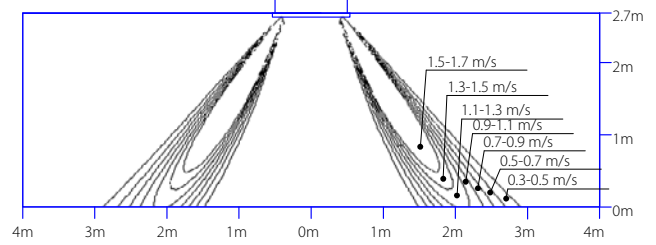

Air temperature distribution (heating)

Air flow direction: vertical
Air discharge: all-round

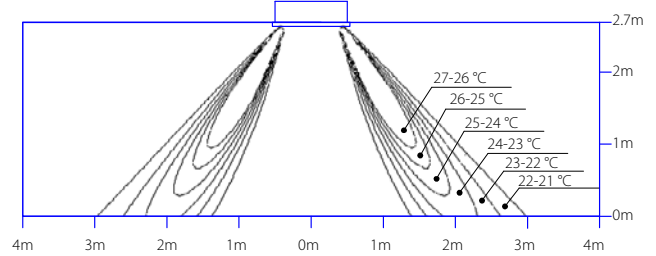

3D121622A

FCAG125-140B

Air velocity distribution (cooling)

Air flow direction: horizontal
Air discharge: all-round

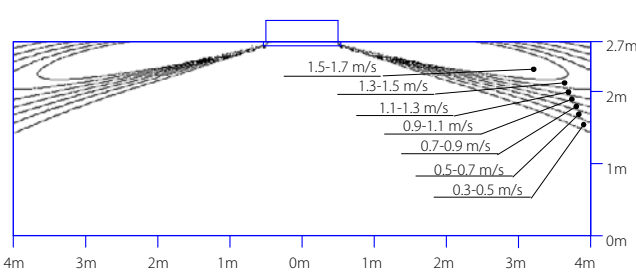

Air temperature distribution (cooling)

Air flow direction: horizontal
Air discharge: all-round

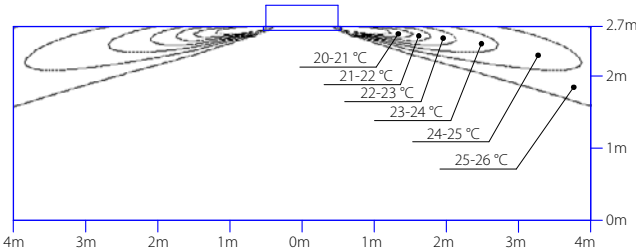

Air velocity distribution (heating)

Air flow direction: vertical
Air discharge: all-round

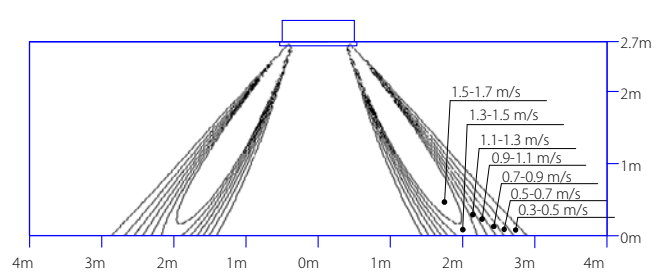

Air temperature distribution (heating)

Air flow direction: vertical
Air discharge: all-round

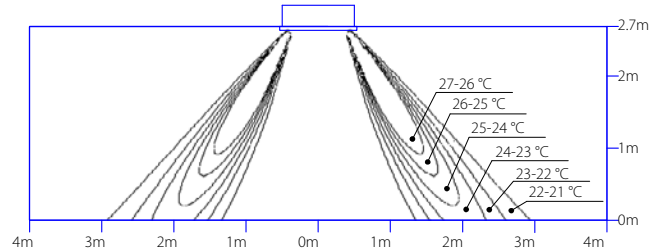

3D121623

FCAHG71H

Air velocity distribution (cooling)

Air flow direction: horizontal
Air discharge: all-round

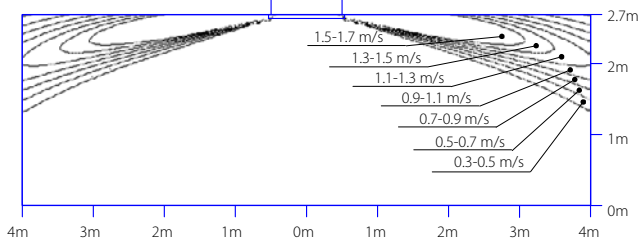

Air temperature distribution (cooling)

Air flow direction: horizontal
Air discharge: all-round

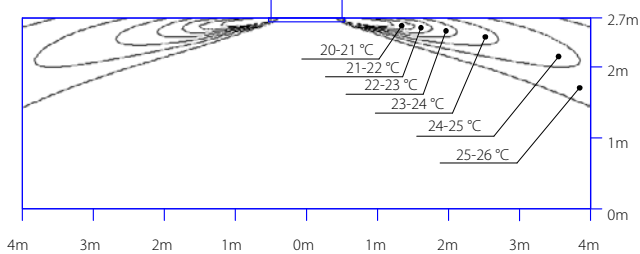

Air velocity distribution (heating)

Air flow direction: vertical
Air discharge: all-round

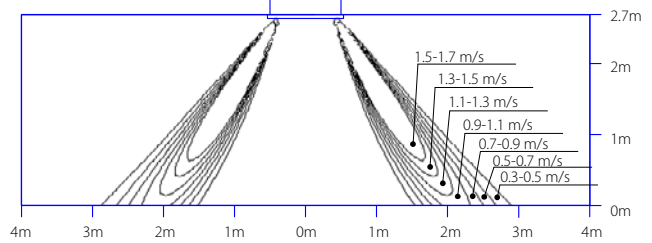

Air temperature distribution (heating)

Air flow direction: vertical
Air discharge: all-round

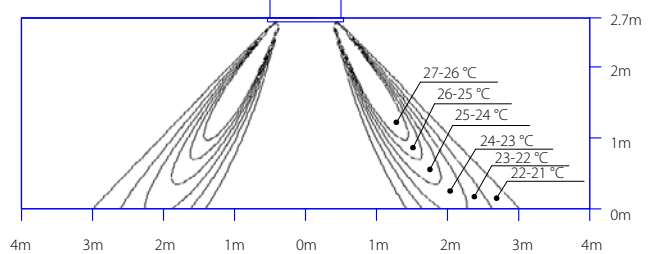

3D121624

FCAHG100H

Air velocity distribution (cooling)

Air flow direction: horizontal
Air discharge: all-round

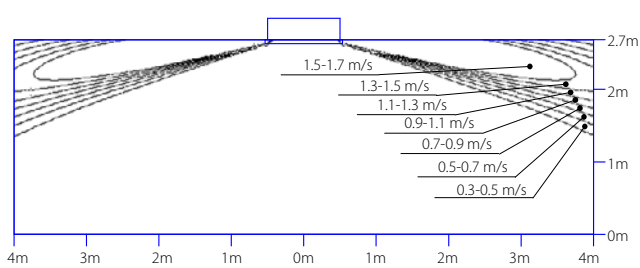

Air temperature distribution (cooling)

Air flow direction: horizontal
Air discharge: all-round

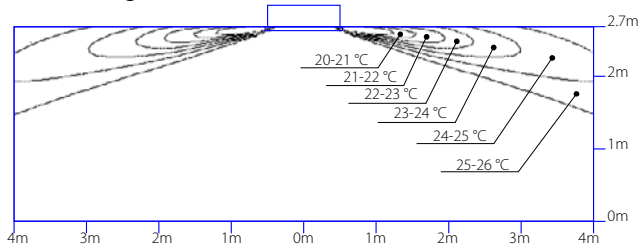

Air velocity distribution (heating)

Air flow direction: vertical
Air discharge: all-round

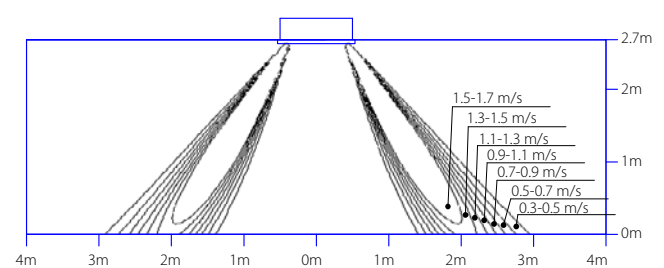

Air temperature distribution (heating)

Air flow direction: vertical
Air discharge: all-round

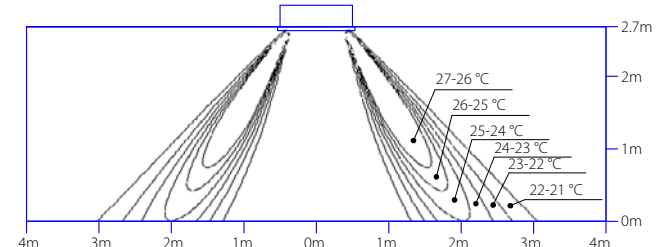

3D121625



FCAHG125-140H

Air velocity distribution (cooling)

Air flow direction: horizontal

Air discharge: all-round

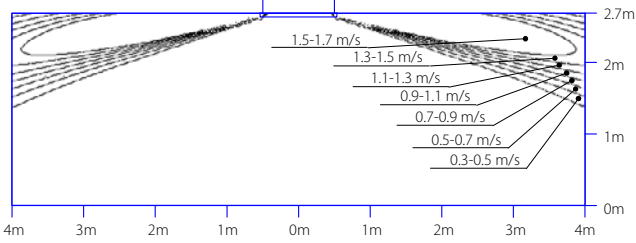

Air temperature distribution (cooling)

Air flow direction: horizontal

Air discharge: all-round

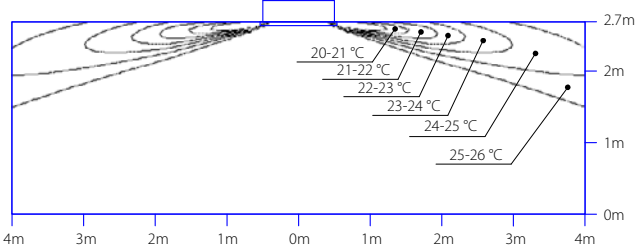

Air velocity distribution (heating)

Air flow direction: vertical

Air discharge: all-round

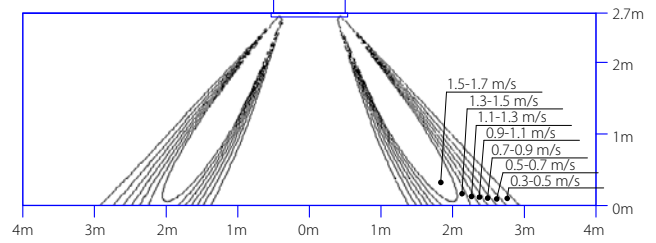

Air temperature distribution (heating)

Air flow direction: vertical

Air discharge: all-round

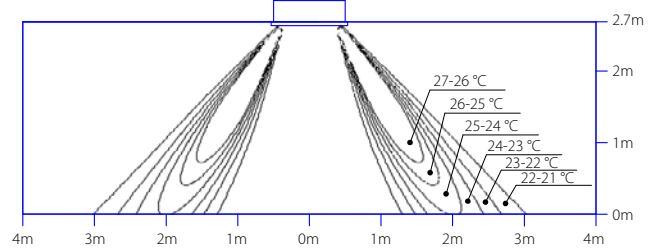

3D121626

DETAILED TECHNICAL DRAWINGS

FFA25-35A9 - FULLY FLAT PANEL

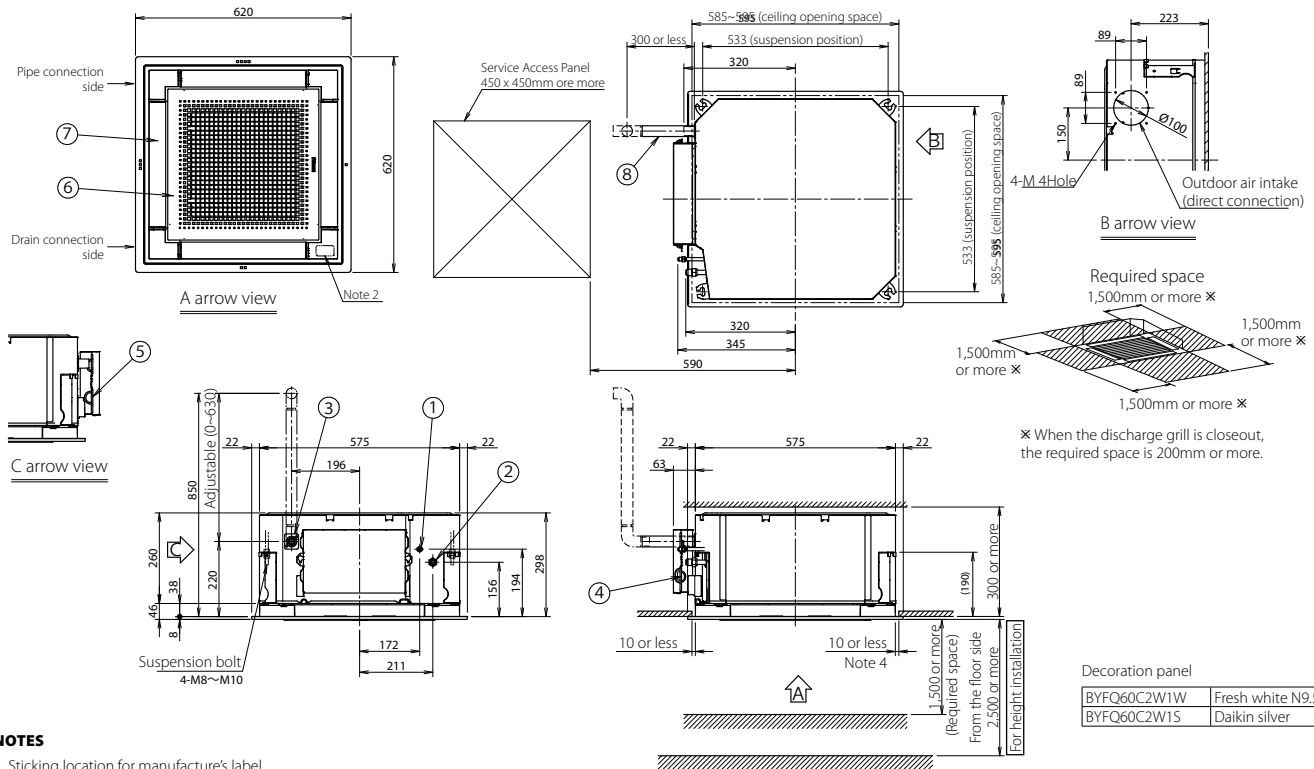

NOTES

1. Sticking location for manufacture's label
Manufacture's label for indoor unit: on the bell mouth inside suction grille
Manufacture's label for decoration panel: on the inner frame inside suction grille
2. In case of using wireless remote controller, this position will be a signal receiver. Refer to the drawing of wireless remote controller in detail.
3. When the temperature and humidity in the ceiling exceed 30°C and RH 80% or the fresh air is inducted into the ceiling or the unit continues 24 hour operation, an additional insulation (thickness 10mm or more of glasswool or polyethylene foam) is required.
4. Though the installation is acceptable up to maximum of 595mm square ceiling opening, keep the clearance of 10mm or less between the main unit and the ceiling opening so that the panel overlap allowance can be ensured.

Item	Part name	Remark
1	Liquid pipe connection	ø6.4 (flare connection)
2	Gas pipe connection	ø9.5 (flare connection)
3	Drain pipe connection	VP20(O.D. ø26)
4	Power supply connection	
5	Remote control code and control wiring connection	
6	Air discharge outlet	
7	Suction grill	
8	Drain hose (accessory)	I.D. ø25 (outlet)

3D082433

FFA25-35A9 - STANDARD PANEL

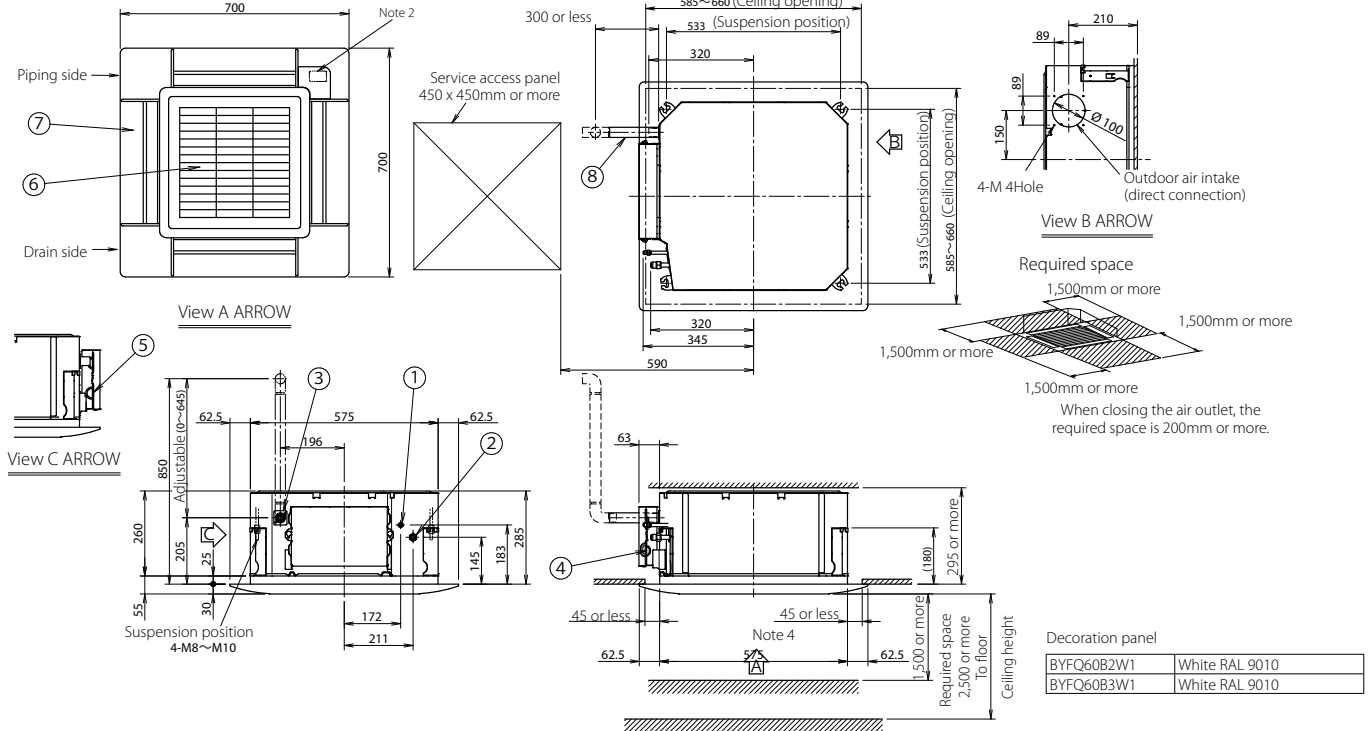

NOTES

1. Location of nameplate
The indoor unit nameplate is located on the bell mouth inside the suction grille.
The decoration panel nameplate is located on the inner frame inside the suction grille.
2. When installing a wireless controller, there will be a receiver on this location. For details, see the drawing of the wireless controller.
3. If any of the following conditions are met, additional insulation (glass wool or polyethylene foam, thickness ≥10mm) is required:
Ambient conditions in the ceiling ≥ 30°C and 80% relative humidity.
Fresh air is inducted into the ceiling.
The unit operates continuously.
4. Though the installation is acceptable up to maximum 660mm square ceiling opening, keep the clearance of 45mm or less between the indoor unit and the ceiling opening, so that the panel overlap allowance can be ensured.

Item	Part name	Remark
1	Liquid pipe connection	ø 6.4 Flare connection
2	Gas pipe connection	ø 9.5 Flare connection
3	Drain pipe connection	VP20 (O.D. ø26)
4	Power supply	
5	Remote control wiring intake	
6	Air discharge grille	
7	Air suction grille	
8	Drain hose Accessory	I.D. ø25 Outlet

3D082434C



FFA50-60A9 - FULLY FLAT PANEL

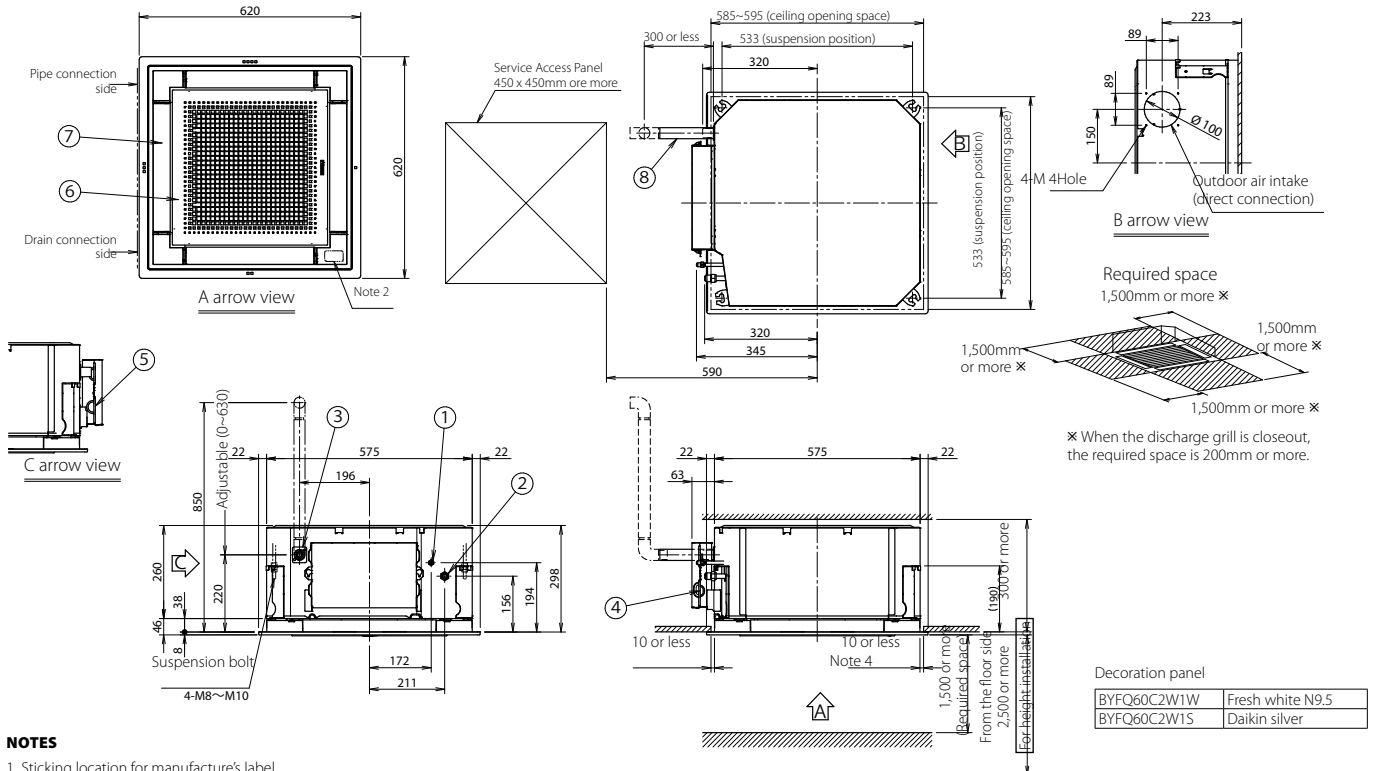

NOTES

- Sticking location for manufacturer's label
Manufacturer's label for indoor unit: on the bell mouth inside suction grille
Manufacturer's label for decoration panel: on the inner frame inside suction grille
- In case of using wireless remote controller, this position will be a signal receiver. Refer to the drawing of wireless remote controller in detail.
- When the temperature and humidity in the ceiling exceed 30°C and RH 80% or the fresh air is inducted into the ceiling or the unit continues 24 hour operation, an additional insulation (thickness 10mm or more of glasswool or polyethylene foam) is required.
- Though the installation is acceptable up to maximum of 595mm square ceiling opening, keep the clearance of 10mm or less between the main unit and the ceiling opening so that the panel overlap allowance can be ensured.

Item	Part name	Remark
1	Liquid pipe connection	ø6.4 (flare connection)
2	Gas pipe connection	ø12.7 (flare connection)
3	Drain pipe connection	VP20(O.D. ø26)
4	Power supply connection	
5	Remote control code and control wiring connection	
6	Air discharge outlet	
7	Suction grill	
8	Drain hose (accessory)	I.D. ø25 (outlet)

3D082052

FFA50-60A9 - STANDARD PANEL

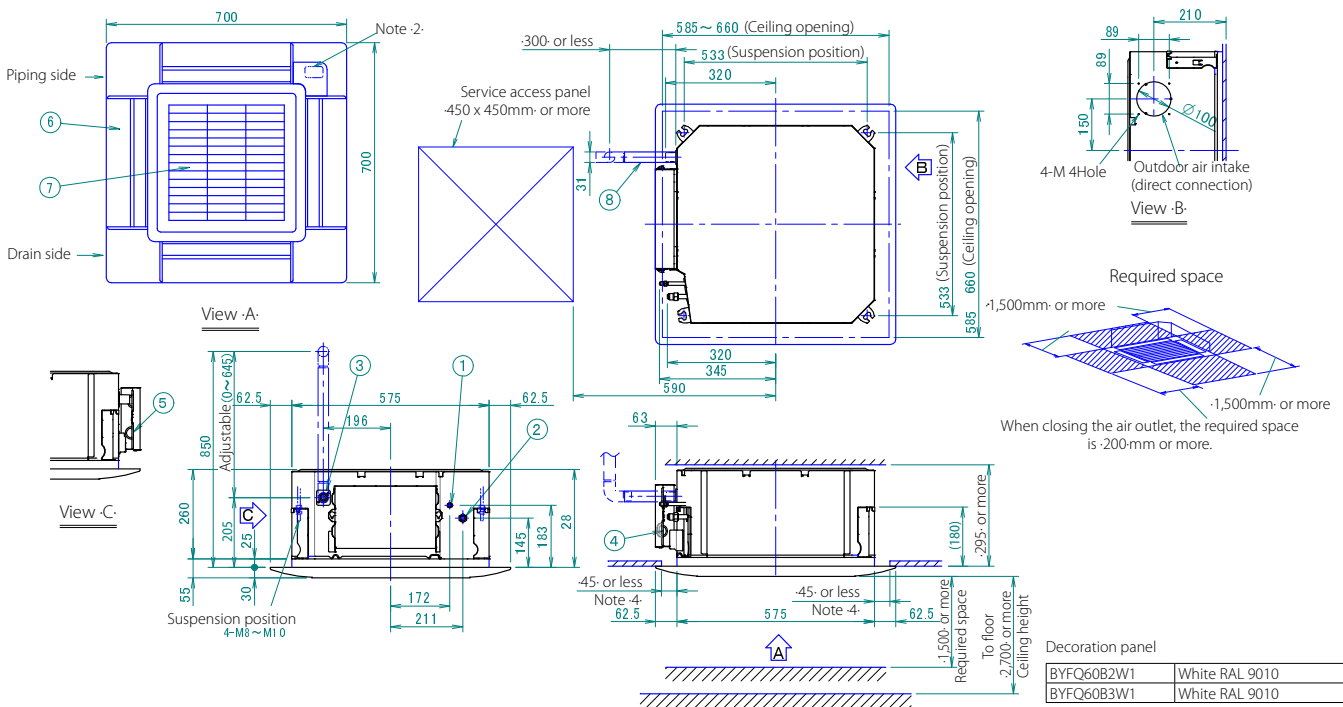

NOTES

- Location of nameplate
The indoor unit nameplate is located on the bell mouth inside the suction grille.
The decoration panel nameplate is located on the inner frame inside the suction grille.
- When installing a wireless controller, there will be a receiver on this location. For details, see the drawing of the wireless controller.
- If any of the following conditions are met, additional insulation (glass wool or polyethylene foam, thickness ≥10mm) is required:
Ambient conditions in the ceiling ≥ 30°C and 80% relative humidity.
Fresh air is inducted into the ceiling.
The unit operates continuously.
- Though the installation is acceptable up to maximum 660-mm square ceiling opening, keep the clearance of 45-mm or less between the indoor unit and the ceiling opening, so that the panel overlap allowance can be ensured.

Item	Part name	Part name
1	Liquid pipe connection -ø 6.4	
2	Gas pipe connection -ø 12.7	
3	Drain outlet -VP20-Outer: ø26-	
4	Power supply	
5	Remote control wiring intake	
6	Air discharge grille	
7	Air suction grille	
8	Drain hose	Inner: ø25-

3D082161D

FFA25A9

Air velocity distribution (cooling)

Air flow direction: horizontal
Air discharge: all-round

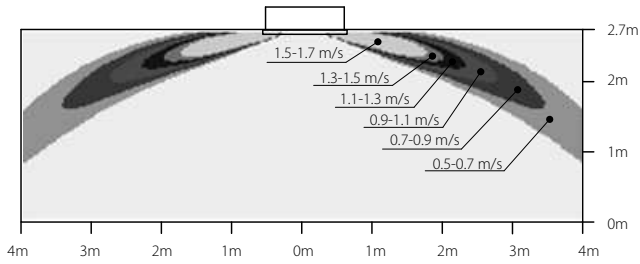

Air velocity distribution (heating)

Air flow direction: vertical
Air discharge: all-round

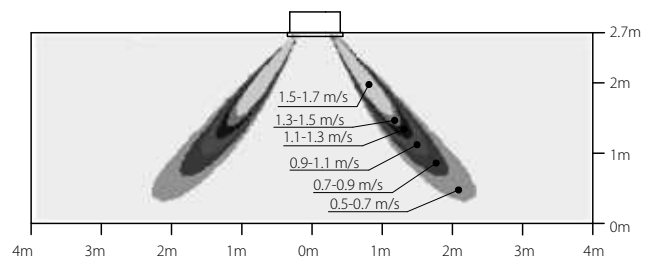

Air temperature distribution (cooling)

Air flow direction: horizontal
Air discharge: all-round

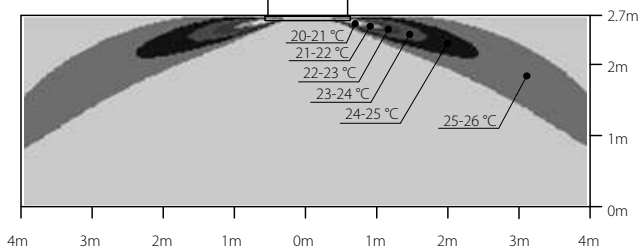

Air temperature distribution (heating)

Air flow direction: vertical
Air discharge: all-round

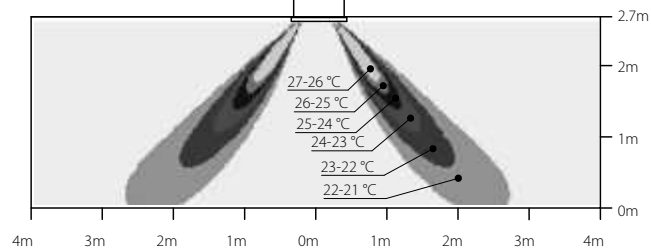

4D083819A

4D083829A

FFA35A9

Air velocity distribution (cooling)

Air flow direction: horizontal
Air discharge: all-round

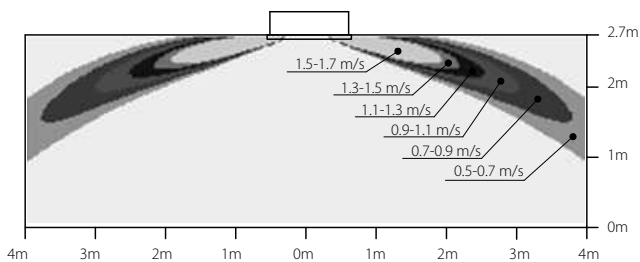

Air velocity distribution (heating)

Air flow direction: vertical
Air discharge: all-round

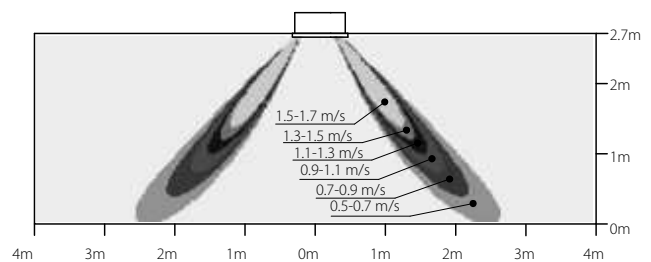

Air temperature distribution (cooling)

Air flow direction: horizontal
Air discharge: all-round

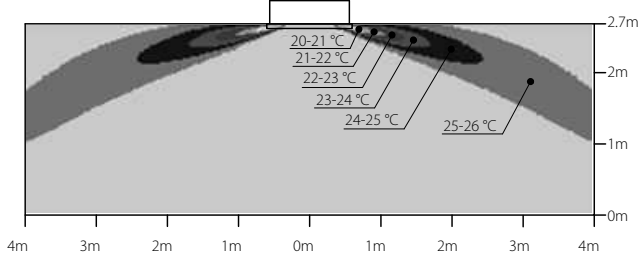

Air temperature distribution (heating)

Air flow direction: vertical
Air discharge: all-round

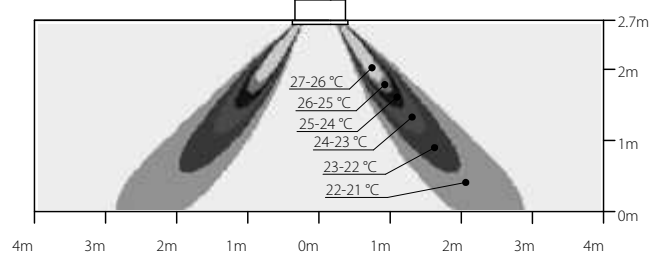

4D083820A

4D083830A



FFA50A9

Air velocity distribution (cooling)

Air flow direction: horizontal

Air discharge: all-round

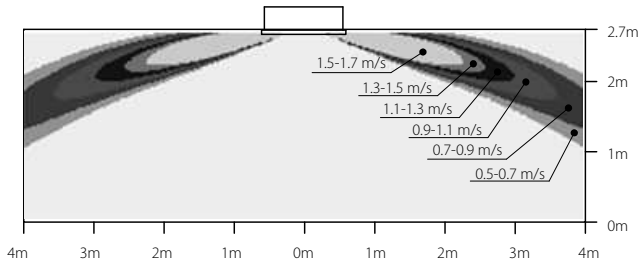

Air velocity distribution (heating)

Air flow direction: vertical

Air discharge: all-round

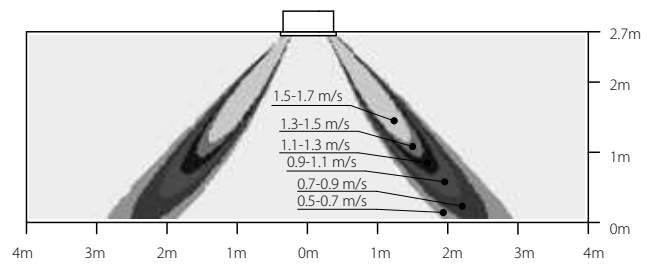

Air temperature distribution (cooling)

Air flow direction: horizontal

Air discharge: all-round

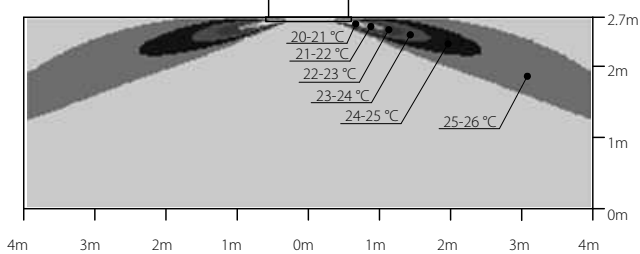

Air temperature distribution (heating)

Air flow direction: vertical

Air discharge: all-round

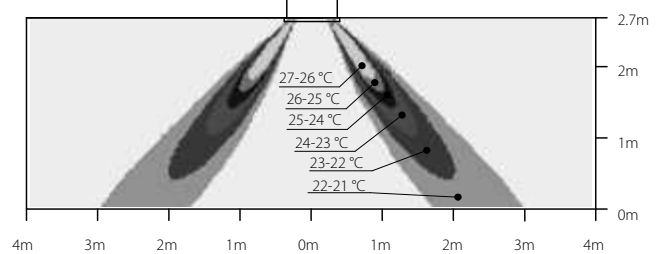

4D083821A

4D083831A

FFA60A9

Air velocity distribution (cooling)

Air flow direction: horizontal

Air discharge: all-round

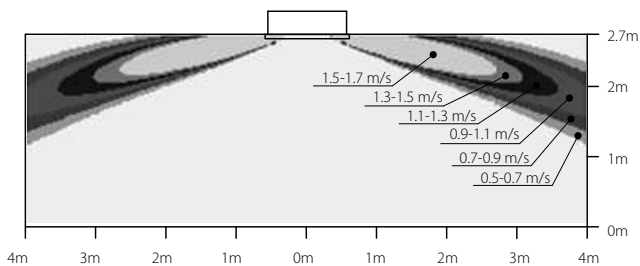

Air velocity distribution (heating)

Air flow direction: vertical

Air discharge: all-round

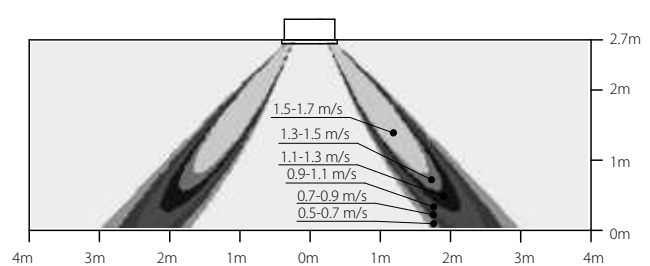

Air temperature distribution (cooling)

Air flow direction: horizontal

Air discharge: all-round

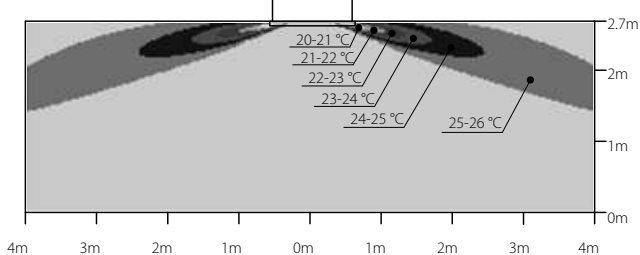

Air temperature distribution (heating)

Air flow direction: vertical

Air discharge: all-round

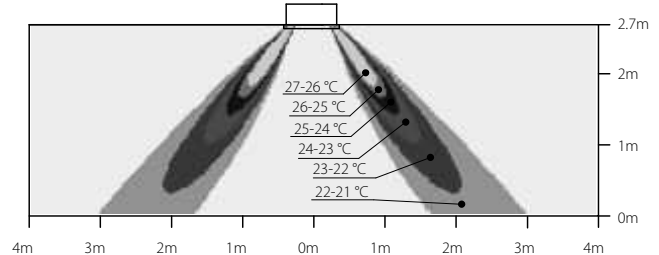

4D083822A

4D083832A

DETAILED TECHNICAL DRAWINGS

FDXM25-35F9

NOTES

- In case of back suction, mount chamber cover to bottom side of the unit.
In case of bottom suction, mount chamber cover to back side of the unit.
- Location of unit name plate: control box cover.
- Mount the air filter at the suction side. (Use an air filter whose dust collecting efficiency is at least 50% in a gravimetric technique).
It can not be equipped with air filter (accessory) when connecting duct to suction side.

Item	Name	Description
1	Liquid pipe connection	ø6.4 (flare connection)
2	Gas pipe connection	ø9.5 (flare connection)
3	Socket for drain	VP20 (O.D. ø26, I.D. ø20)
4	Drain hose (accessory)	I.D. ø25 (outlet)
5	Control box	
6	Transmission wiring	
7	Power supply connection	
8	Suspension bracket	
9	Air filter (accessory)	

3D081343

FDXM50-60F9

Item	Name	Description
1	Liquid pipe connection	ø6.4 (flare connection)
2	Gas pipe connection	ø12.7 (flare connection)
3	Socket for drain	VP20 (O.D. ø26, I.D. ø20)
4	Drain hose (accessory)	I.D. ø25 (outlet)
5	Control box	
6	Transmission wiring	
7	Power supply connection	
8	Suspension bracket	
9	Air filter (accessory)	

NOTES

- In case of back suction, mount chamber cover to bottom side of the unit.
In case of bottom suction, mount chamber cover to back side of the unit.
- Location of unit name plate: control box cover.
- Mount the air filter at the suction side. (Use an air filter whose dust collecting efficiency is at least 50% in a gravimetric technique).
It can not be equipped with air filter (accessory) when connecting duct to suction side.

3D081360



FDXM25-35F9

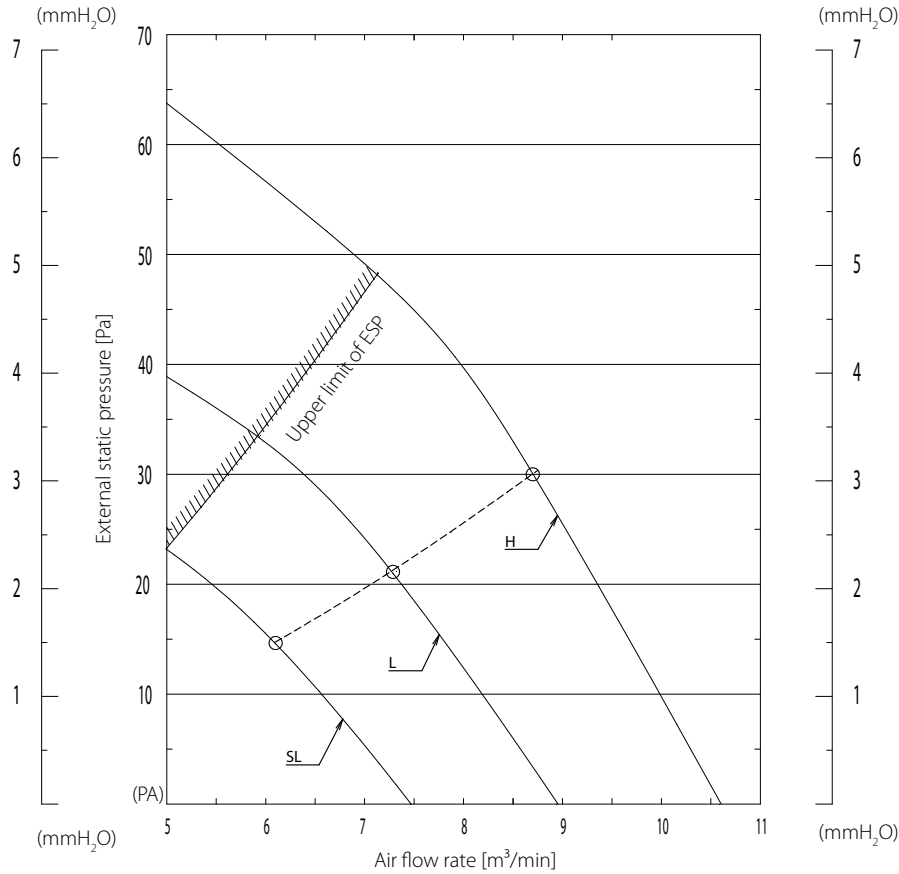

3D081327C

FDXM50F9

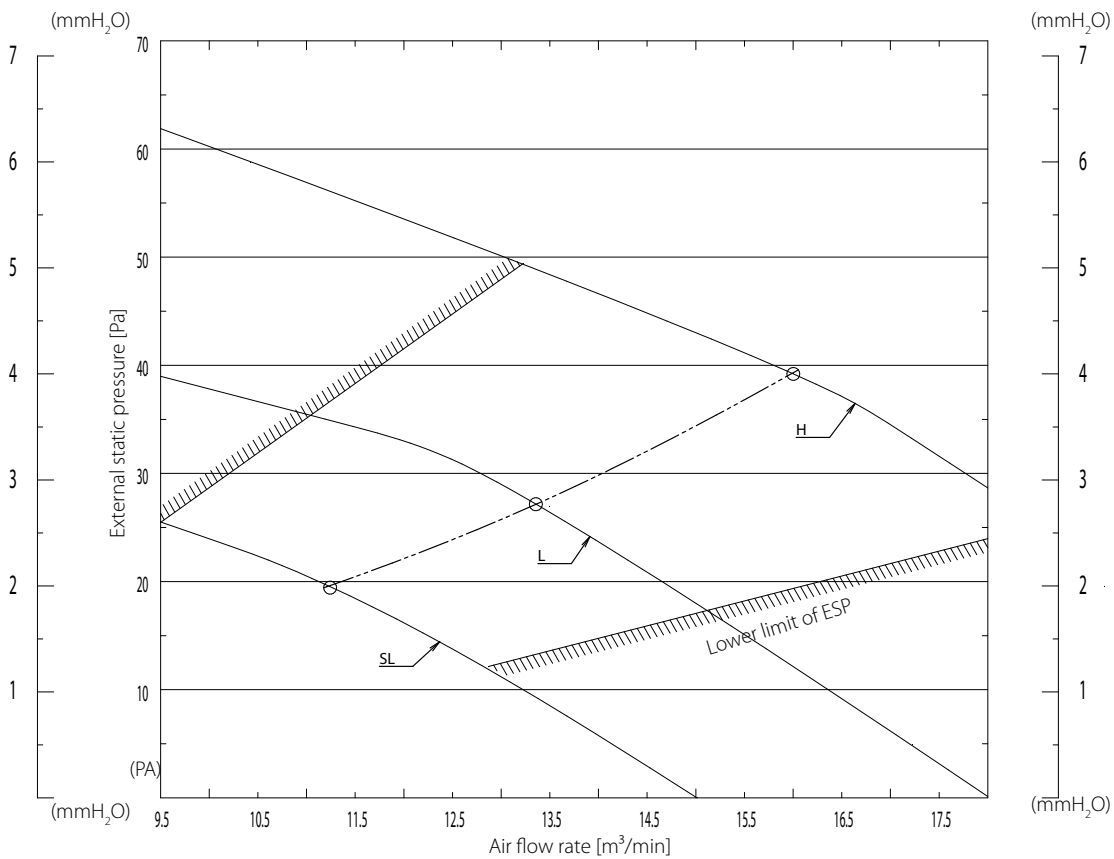

3D085960C

FDXM60F9

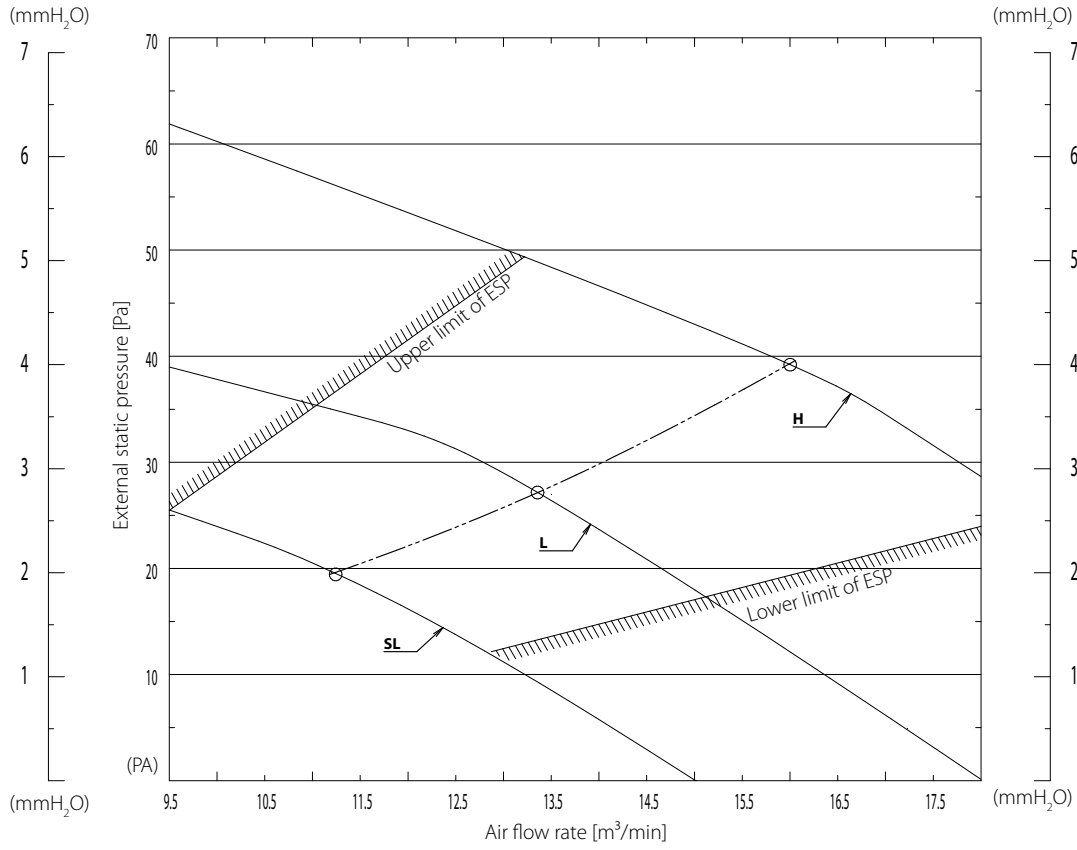

3D081329C



FBA35A9

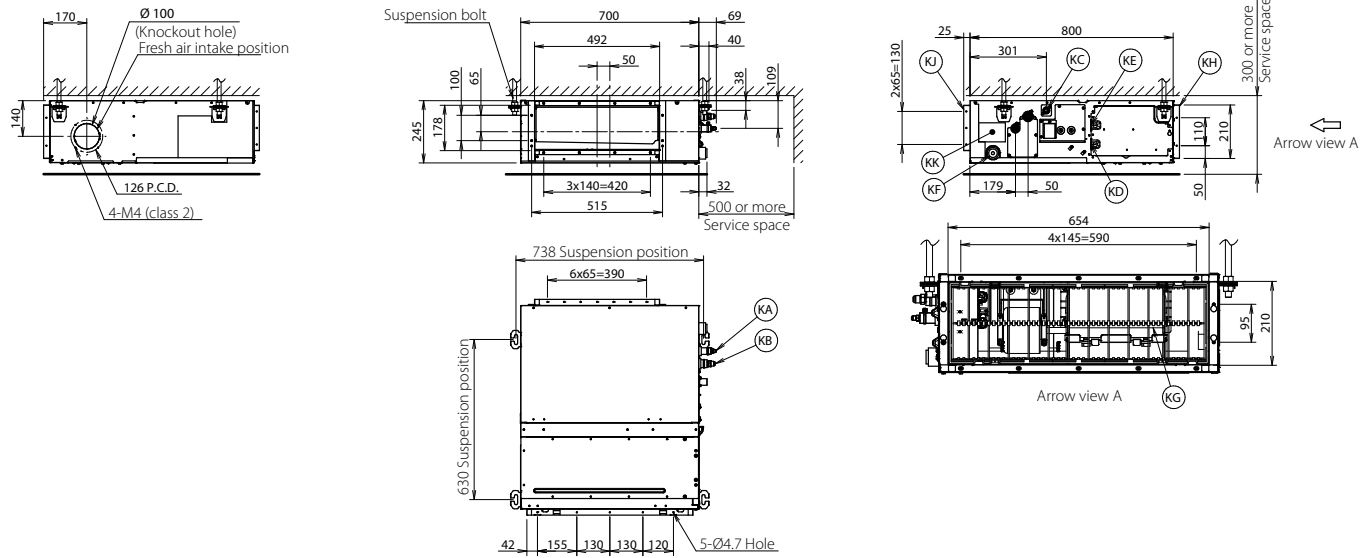

Item	Name	Description
KA	Liquid pipe connection port	ø6.35 flared connection
KB	Gas pipe connection port	ø9.52 flared connection
KC	Drain pipe connection	VP20 (OD ø26, ID ø20)
KD	Wiring connection	/
KE	Power supply connection	/
KF	Drain outlet	VP20 (OD ø26, ID ø20)
KG	Air filter	/
KH	Air suction side	/
KJ	Air discharge side	/
KK	Nameplate	/

NOTES

1. When installing optional accessories, refer to their respective documentation.
2. The ceiling depth varies according to the documentation of the specific system.

3D094988B

FBA50A9

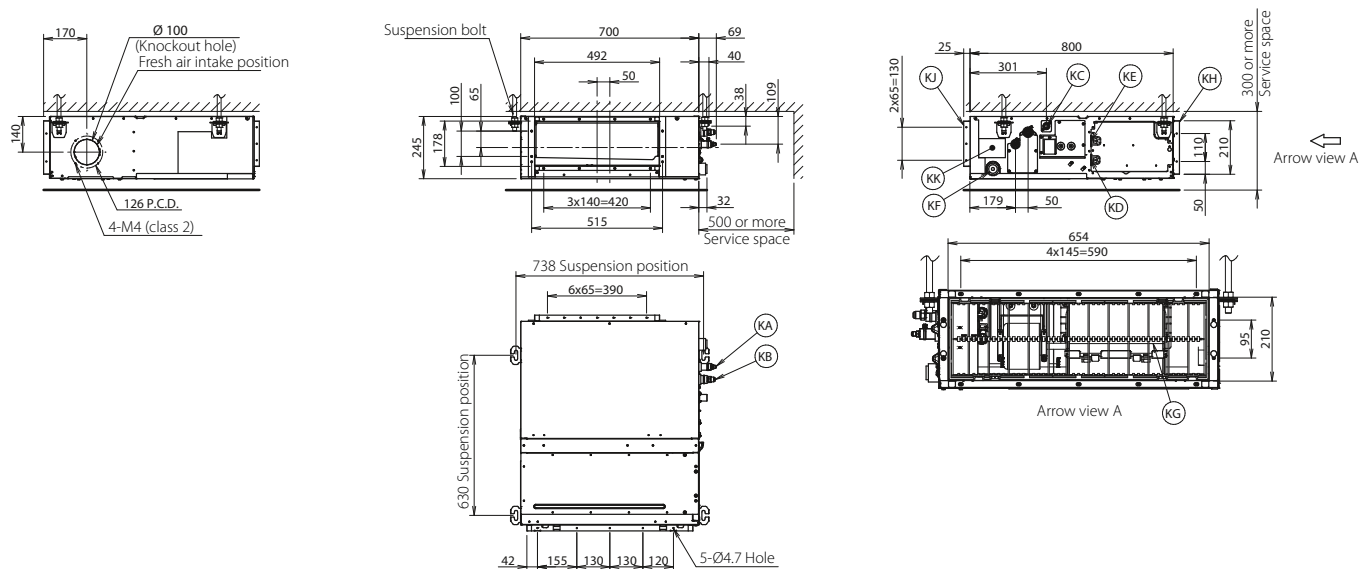

Item	Name	Description
KA	Liquid pipe connection port	ø6.35 flared connection
KB	Gas pipe connection port	ø12.70 flared connection
KC	Drain pipe connection	VP20 (OD ø26, ID ø20)
KD	Wiring connection	/
KE	Power supply connection	/
KF	Drain outlet	VP20 (OD ø26, ID ø20)
KG	Air filter	/
KH	Air suction side	/
KJ	Air discharge side	/
KK	Nameplate	/

NOTES

1. When installing optional accessories, refer to their respective documentation.
2. The ceiling depth varies according to the documentation of the specific system.

3D094918B

DETAILED TECHNICAL DRAWINGS

FBA60A9

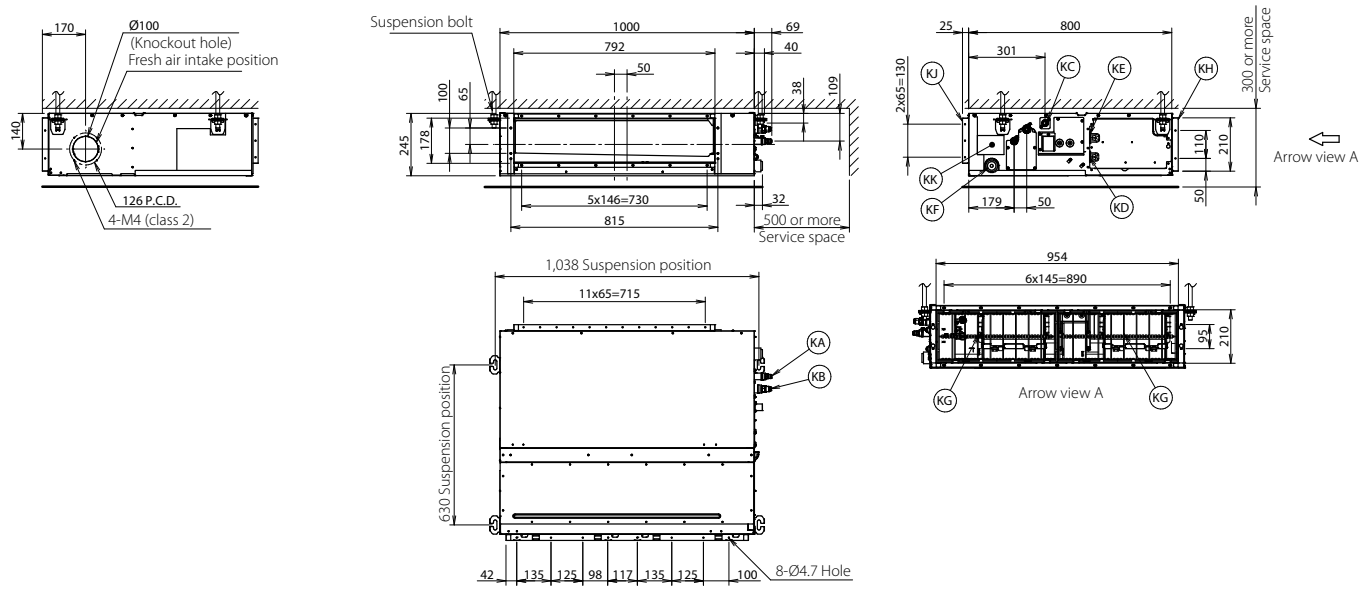

Item	Name	Description
KA	Liquid pipe connection port	ø6.35 flared connection
KB	Gas pipe connection port	ø12.70 flared connection
KC	Drain pipe connection	VP20 (OD ø26, ID ø20)
KD	Wiring connection	/
KE	Power supply connection	/
KF	Drain outlet	VP20 (OD ø26, ID ø20)
KG	Air filter	/
KH	Air suction side	/
KJ	Air discharge side	/
KK	Nameplate	/

NOTES

1. When installing optional accessories, refer to their respective documentation.
2. The ceiling depth varies according to the documentation of the specific system.

3D094983B

FBA71A9

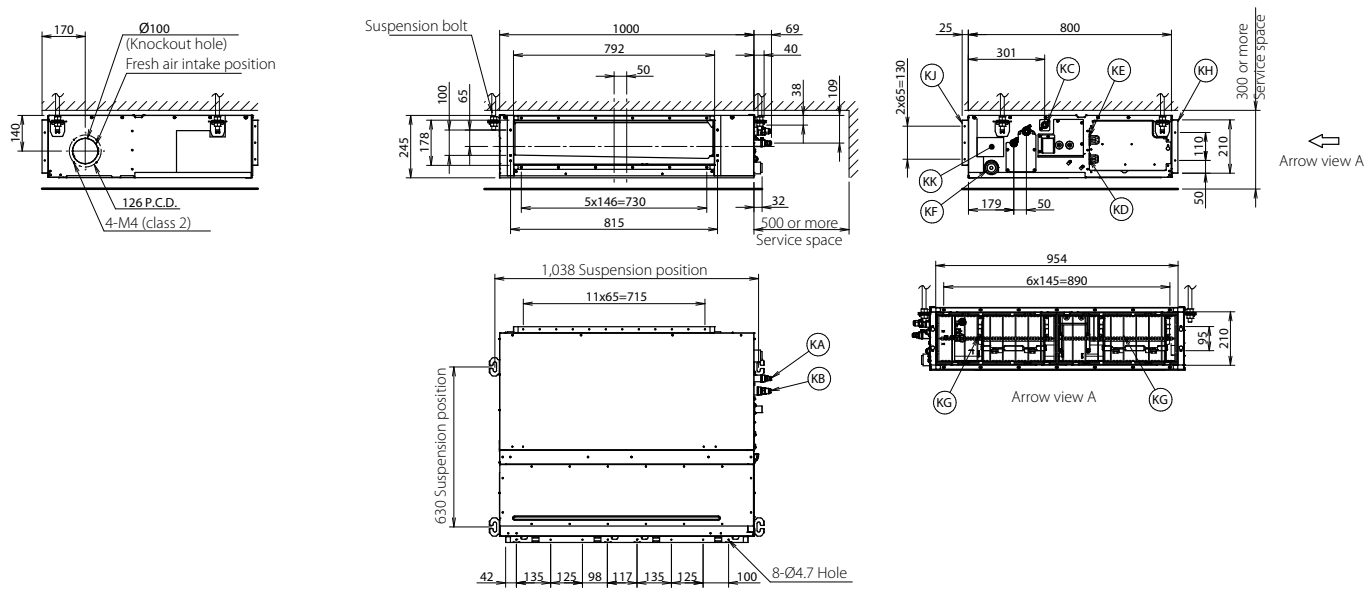

Item	Name	Description
KA	Liquid pipe connection port	ø9.52 flared connection
KB	Gas pipe connection port	ø15.90 flared connection
KC	Drain pipe connection	VP20 (OD ø26, ID ø20)
KD	Wiring connection	/
KE	Power supply connection	/
KF	Drain outlet	VP20 (OD ø26, ID ø20)
KG	Air filter	/
KH	Air suction side	/
KJ	Air discharge side	/
KK	Nameplate	/

NOTES

1. When installing optional accessories, refer to their respective documentation.
2. The ceiling depth varies according to the documentation of the specific system.

3D094915B



FBA100-140A

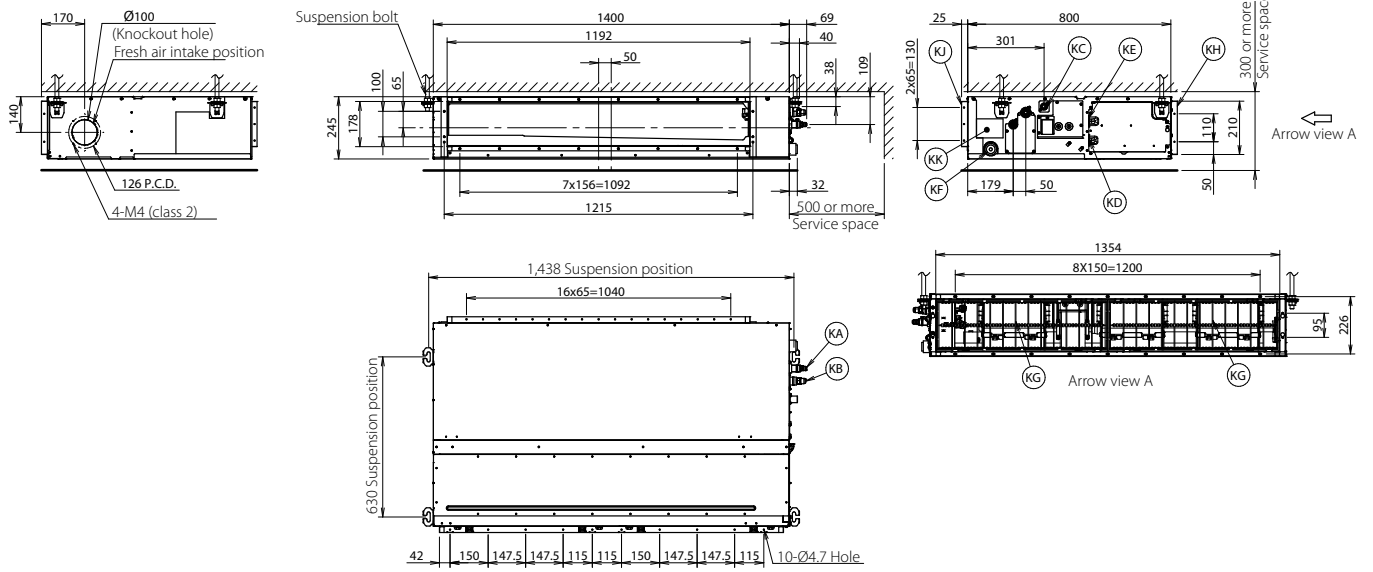

Item	Name	Description
KA	Liquid pipe connection port	ø9.52 flared connection
KB	Gas pipe connection port	ø15.90 flared connection
KC	Drain pipe connection	VP20 (OD ø26, ID ø20)
KD	Wiring connection	/
KE	Power supply connection	/
KF	Drain outlet	VP20 (OD ø26, ID ø20)
KG	Air filter	/
KH	Air suction side	/
KJ	Air discharge side	/
KK	Nameplate	/

NOTES

1. When installing optional accessories, refer to their respective documentation.
2. The ceiling depth varies according to the documentation of the specific system.

3D094914B

FBA35-50A9

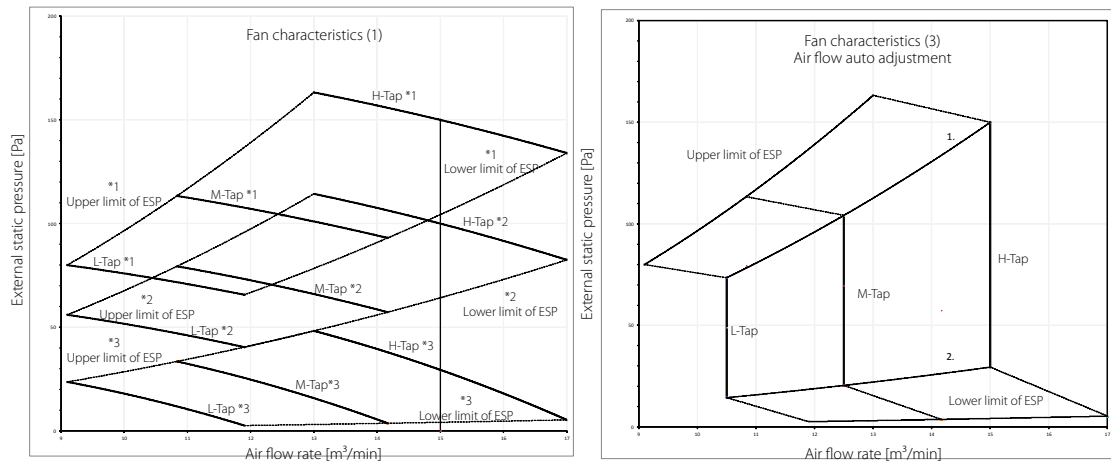

1. Upper limit of ESP by air flow auto adjustment
2. Lower limit of ESP by air flow auto adjustment

Mark		ESP [Pa]
*1	Maximum	150
*2	-	100
*3	Standard	30

NOTES

1. The fan characteristics shown are in "fan only" mode.
2. ESP: External Static Pressure

3D095521B

DETAILED TECHNICAL DRAWINGS

FBA60-71A9

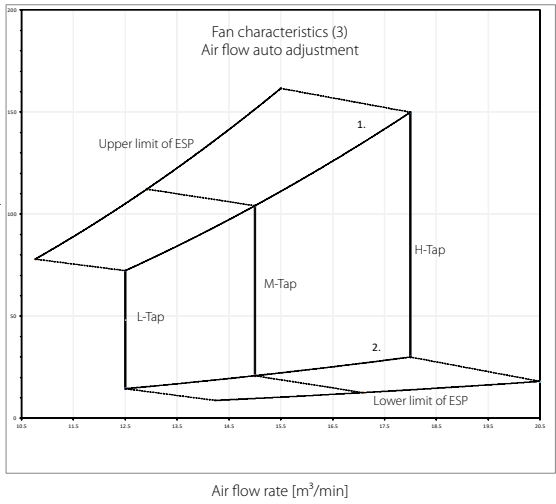
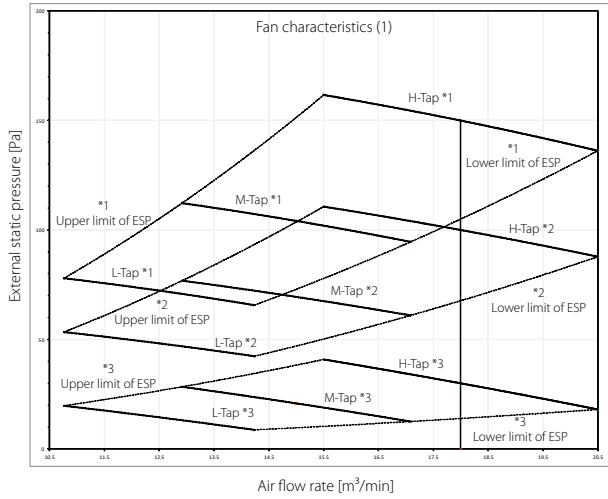

- 1. Upper limit of ESP by air flow auto adjustment
- 2. Lower limit of ESP by air flow auto adjustment

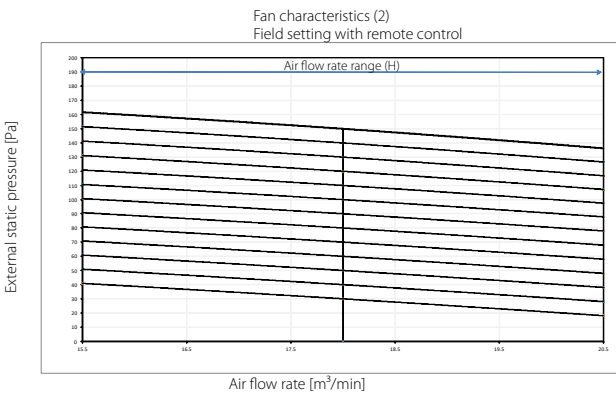

Mark		ESP [Pa]
*1	Maximum	150
*2	-	100
*3	Standard	30

- NOTES**
- 1. The fan characteristics shown are in "fan only" mode.
 - 2. ESP: External Static Pressure

3D095524B

FBA100A

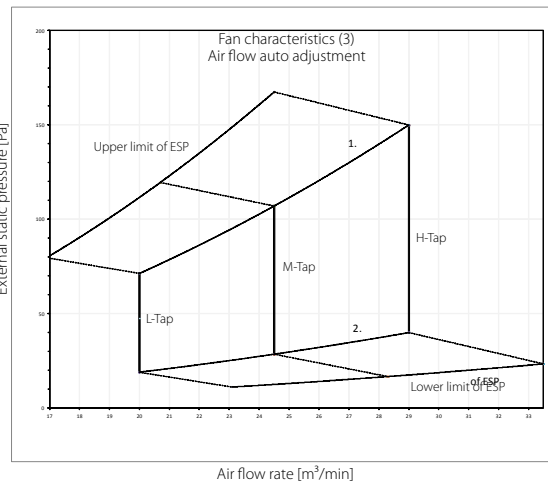
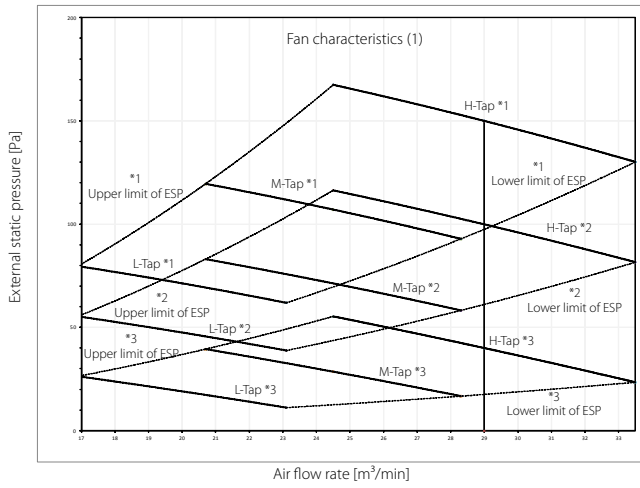

- 1. Upper limit of ESP by air flow auto adjustment
- 2. Lower limit of ESP by air flow auto adjustment

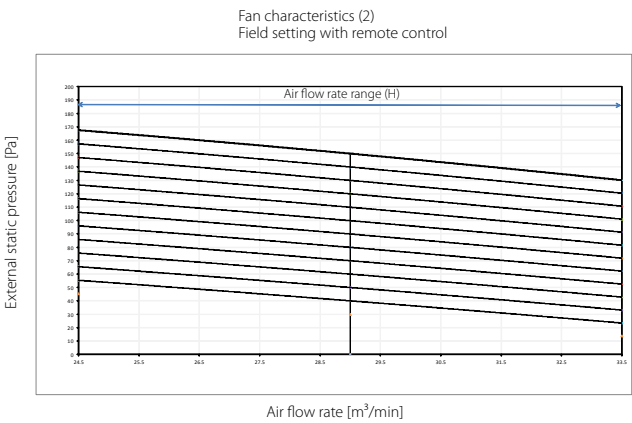

Mark		ESP [Pa]
*1	Maximum	150
*2	-	100
*3	Standard	30

- NOTES**
- 1. The fan characteristics shown are in "fan only" mode.
 - 2. ESP: External Static Pressure

3D095526B



FBA125-140A

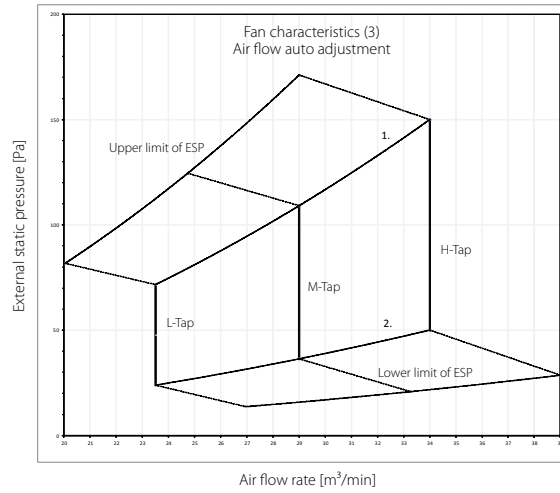
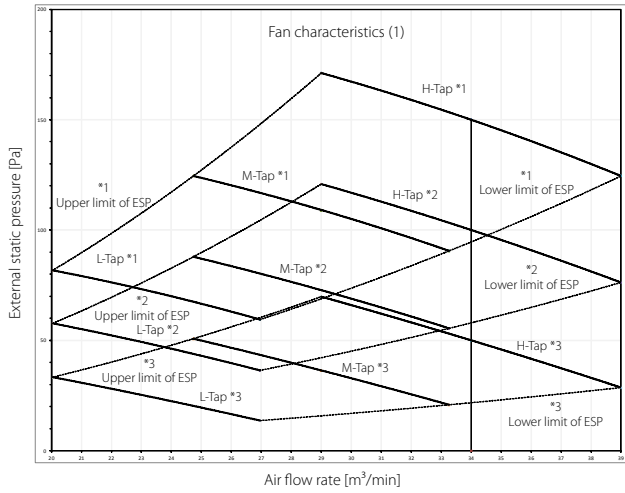

1. Upper limit of ESP by air flow auto adjustment
2. Lower limit of ESP by air flow auto adjustment

Fan characteristics (2)
Field setting with remote control

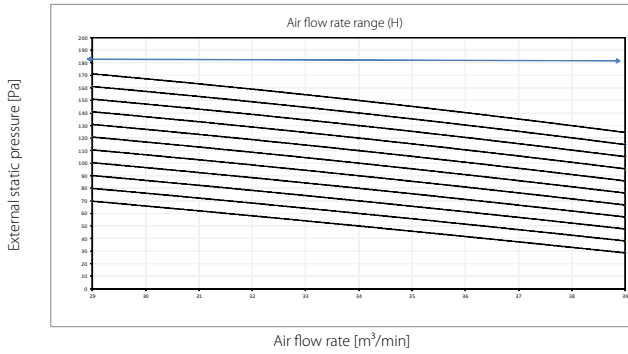

Mark		ESP [Pa]
*1	Maximum	150
*2	-	100
*3	Standard	30

NOTES

1. The fan characteristics shown are in "fan only" mode.
2. ESP: External Static Pressure

3D095527B

DETAILED TECHNICAL DRAWINGS

FDA125A

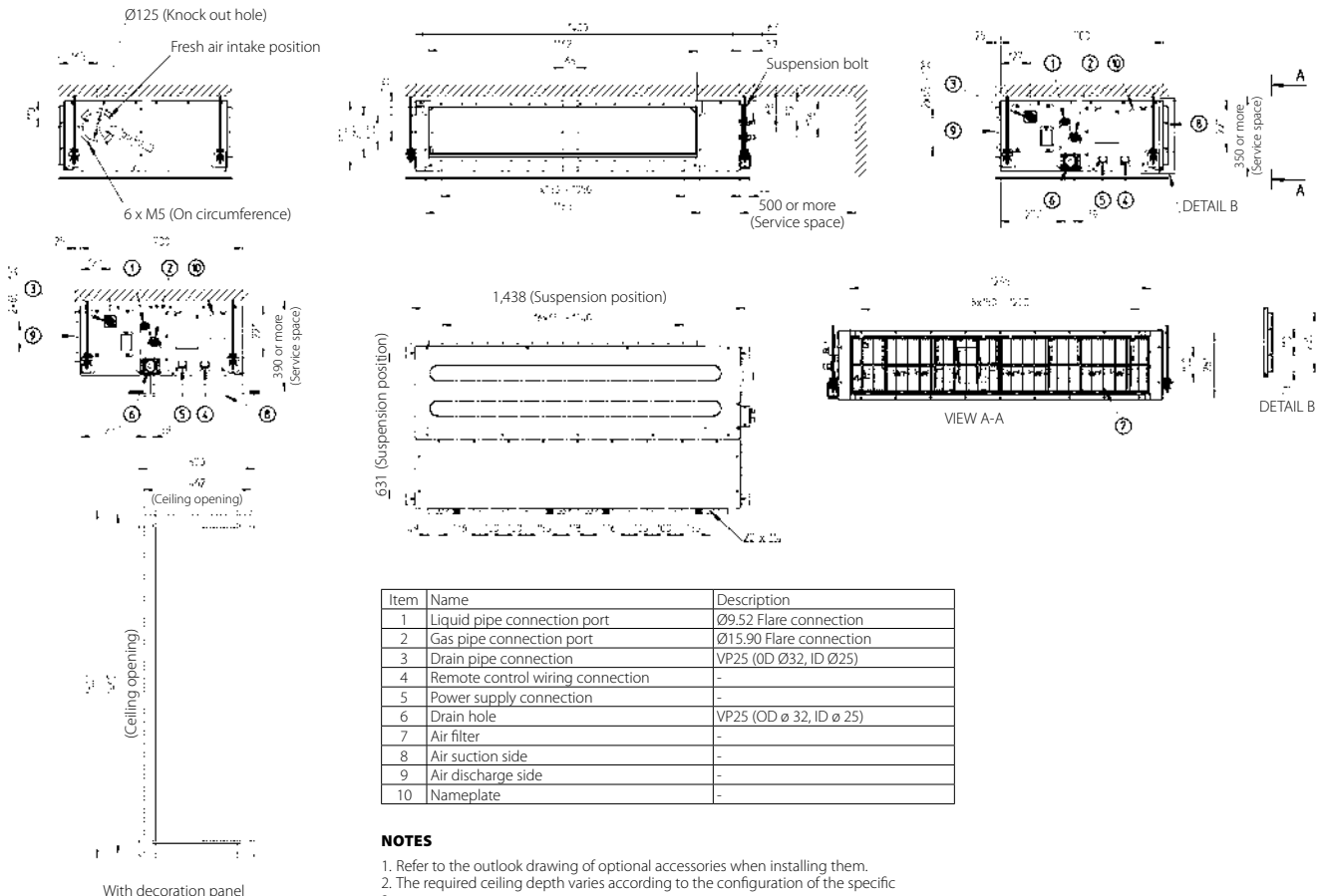

3TW31254-1B

FDA125A

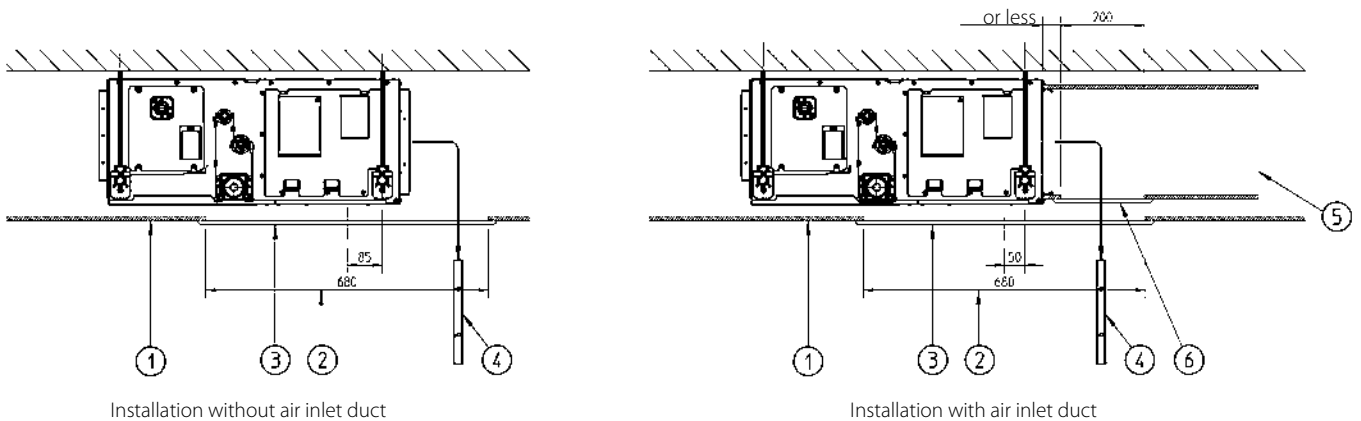

Number	Description
1	Suspended ceiling
2	Ceiling opening
3	Service access panel (optional)
4	Air filter
5	Air inlet duct
6	Duct service opening

- NOTES**
1. When installing the unit with rear suction, a service opening is necessary for the maintenance of the air filters.
 2. When installing the unit with a suction duct, a service opening must be provided in the duct.

3TW31184-4



FDA125A

Fan characteristics (1)

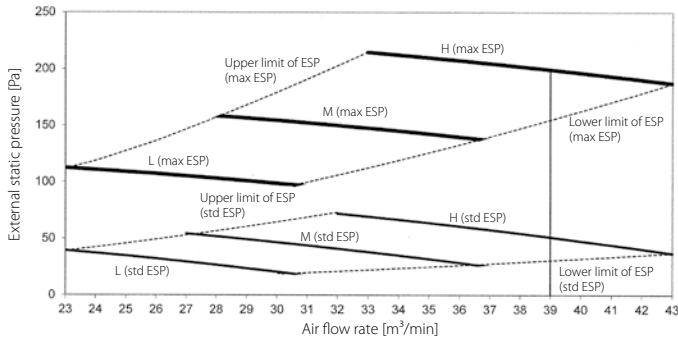

Fan characteristics (2)
(field setting with remote control)
Range of available air flow rate (H)

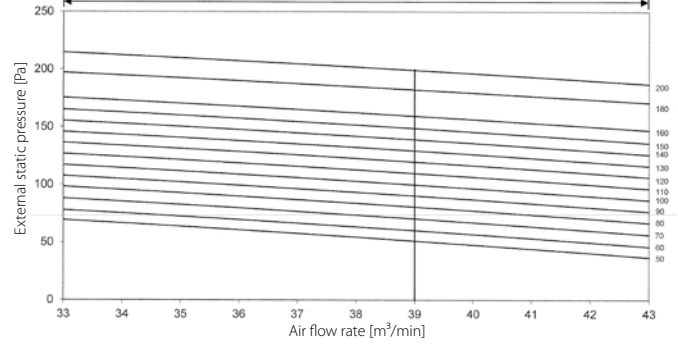

Fan characteristics (3)
(airflow auto adjustment)

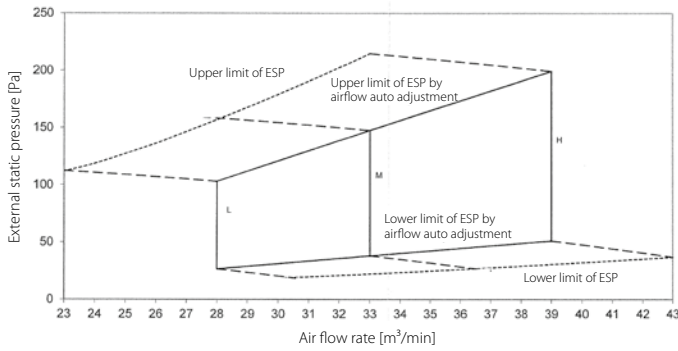

NOTES

1. Fan characteristics as shown are in 'fan only' mode.
2. ESP: External static pressure

3D085254

FDA200-250A

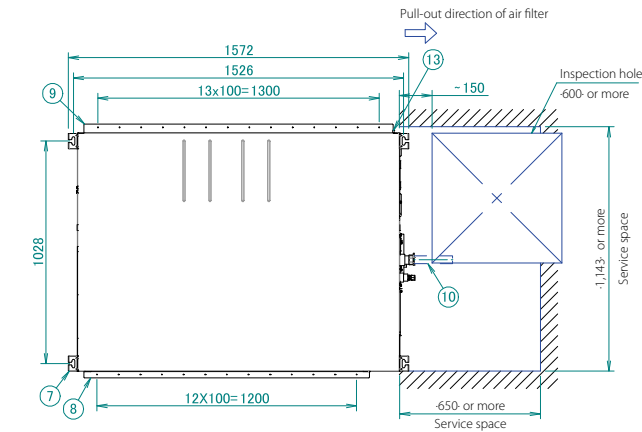

Number	Part name	Description
1	Liquid pipe connection port	Flare connection
2	Gas pipe connection port	Brazed connection
3	Grounding terminal	Located inside of the unit
4	Control box	
5	Power supply wiring intake	
6	Control wiring intake	
7	Hook	M10
8	Air outlet flange	
9	Air inlet flange with air filter	
10	Accessory pipe	Standard accessory
11	Manufacturer label	
12	Drain pipe connection	-1 inch- BSP (female thread)
13	Maintenance cover	Air filter
14	Air filter	

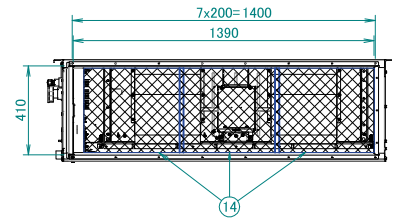
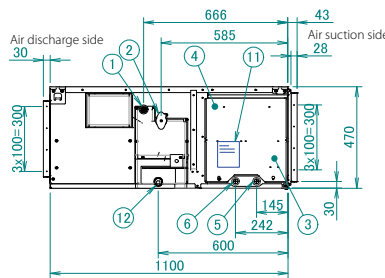
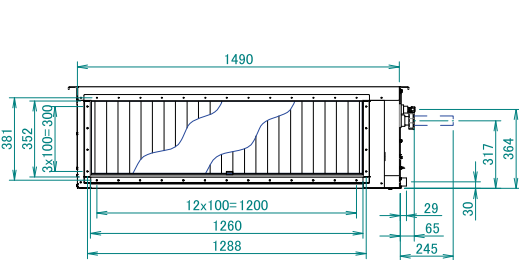

Piping connections Ø		
Indoor unit	Gas pipe	Liquid pipe
FDA200AXVEB	Ø 19.1 Accessory pipe	Ø 9.5
FDA250AXVEB	Ø 19.1 Accessory pipe	Ø 9.5

NOTES

1. The unit nameplate is located on the control box cover.

2D123907

DETAILED TECHNICAL DRAWINGS

FDA200A

Fan characteristics (1)

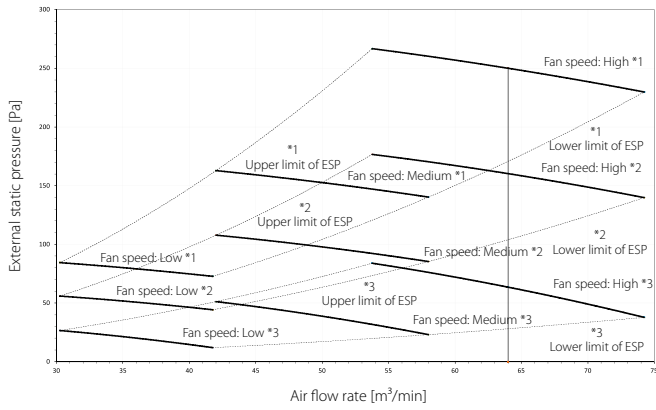

Fan characteristics (2)
 Field setting with remote control

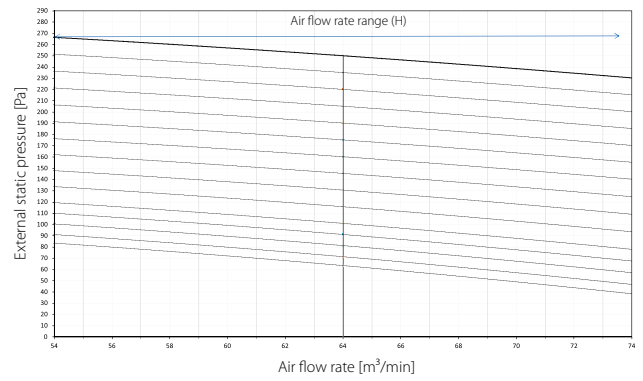

Fan characteristics (3)
 Air flow auto adjustment

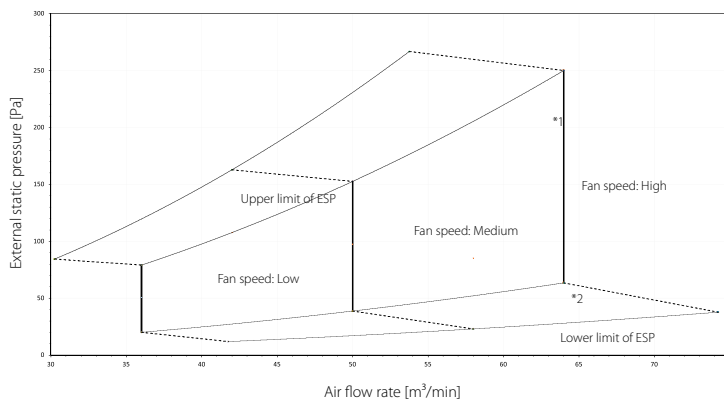

- 1. Upper limit of ESP by air flow auto adjustment
- 2. Lower limit of ESP by air flow auto adjustment

Mark		ESP [Pa]
*1	Maximum	160
*2	-	62
*3	Standard	62

4D124460

FDA250A

Fan characteristics (1)

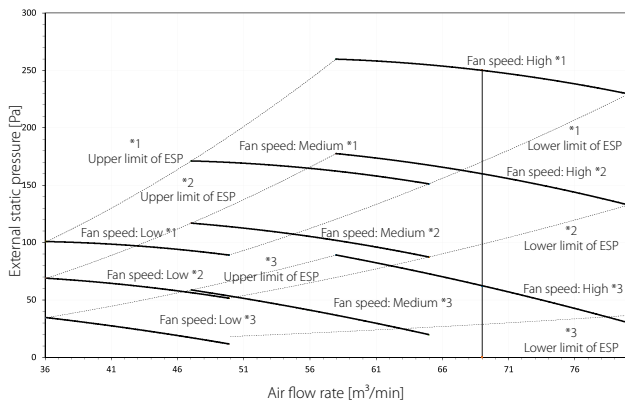

Fan characteristics (2)
 Field setting with remote control

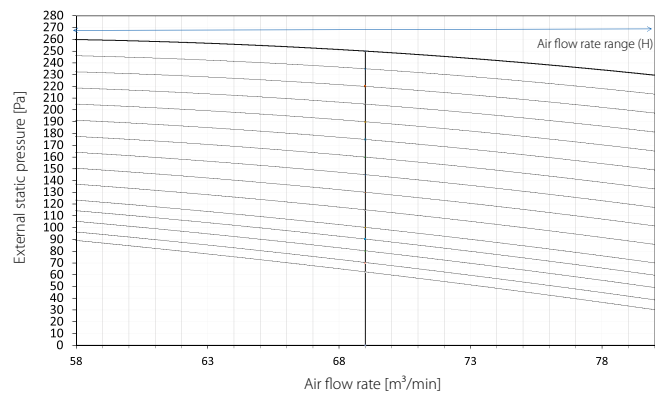

Fan characteristics (3)
 Air flow auto adjustment

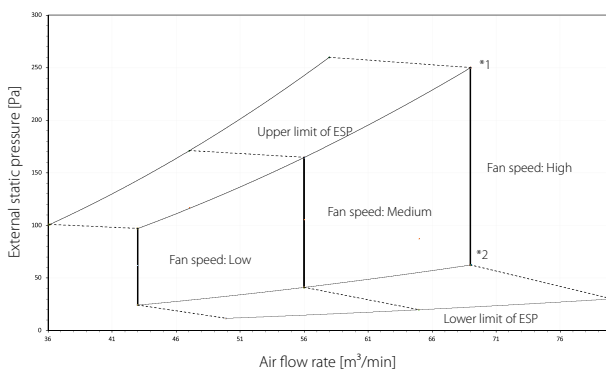

- 1. Upper limit of ESP by air flow auto adjustment
- 2. Lower limit of ESP by air flow auto adjustment

Mark		ESP [Pa]
*1	Maximum	250
*2	-	160
*3	Standard	62

4D124478



ADEA35A

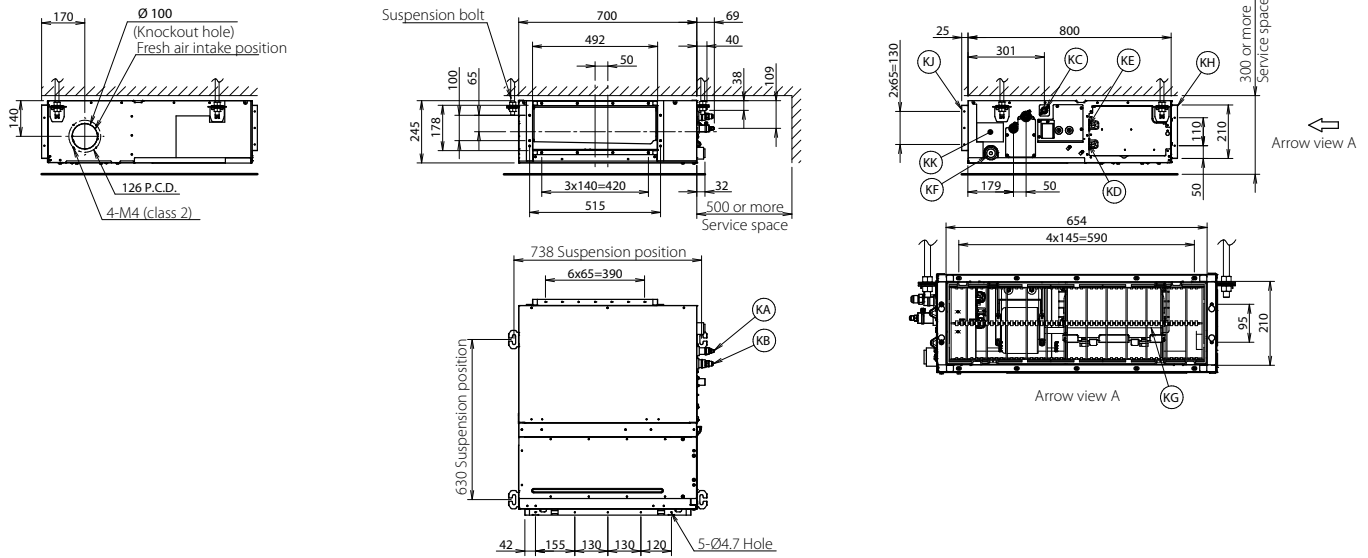

Item	Name	Description
KA	Liquid pipe connection port	ø6.35 flared connection
KB	Gas pipe connection port	ø9.52 flared connection
KC	Drain pipe connection	VP20 (OD ø26, ID ø20)
KD	Wiring connection	/
KE	Power supply connection	/
KF	Drain outlet	VP20 (OD ø26, ID ø20)
KG	Air filter	/
KH	Air suction side	/
KJ	Air discharge side	/
KK	Nameplate	/

NOTES

1. When installing optional accessories, refer to their respective documentation.
2. The ceiling depth varies according to the documentation of the specific system.

3D094988B

ADEA50A

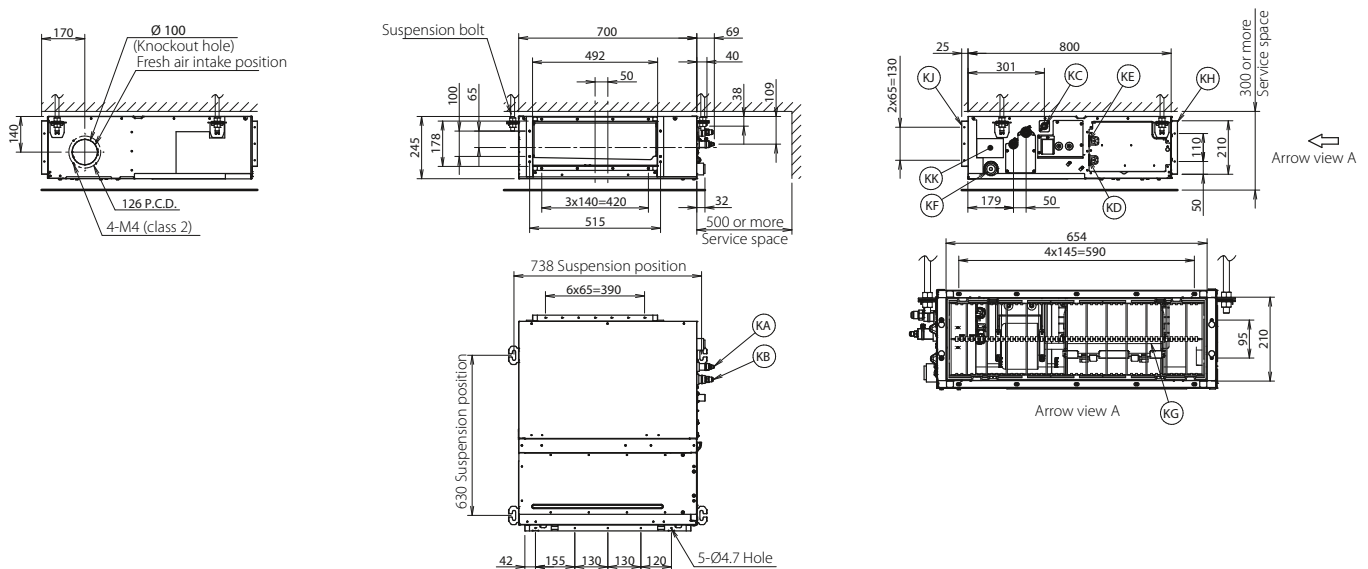

Item	Name	Description
KA	Liquid pipe connection port	ø6.35 flared connection
KB	Gas pipe connection port	ø12.70 flared connection
KC	Drain pipe connection	VP20 (OD ø26, ID ø20)
KD	Wiring connection	/
KE	Power supply connection	/
KF	Drain outlet	VP20 (OD ø26, ID ø20)
KG	Air filter	/
KH	Air suction side	/
KJ	Air discharge side	/
KK	Nameplate	/

NOTES

1. When installing optional accessories, refer to their respective documentation.
2. The ceiling depth varies according to the documentation of the specific system.

3D094918B

DETAILED TECHNICAL DRAWINGS

ADEA60A

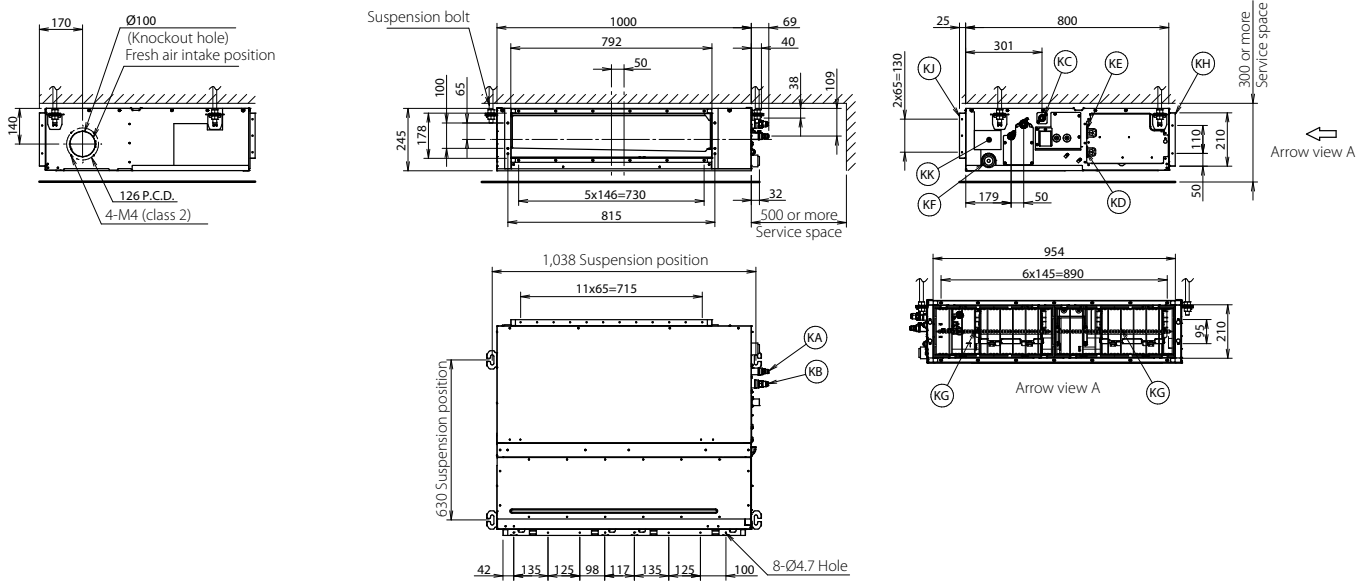

Item	Name	Description
KA	Liquid pipe connection port	ø6.35 flared connection
KB	Gas pipe connection port	ø12.70 flared connection
KC	Drain pipe connection	VP20 (OD ø26, ID ø20)
KD	Wiring connection	/
KE	Power supply connection	/
KF	Drain outlet	VP20 (OD ø26, ID ø20)
KG	Air filter	/
KH	Air suction side	/
KJ	Air discharge side	/
KK	Nameplate	/

NOTES

1. When installing optional accessories, refer to their respective documentation.
2. The ceiling depth varies according to the documentation of the specific system.

3D094983B

ADEA71A

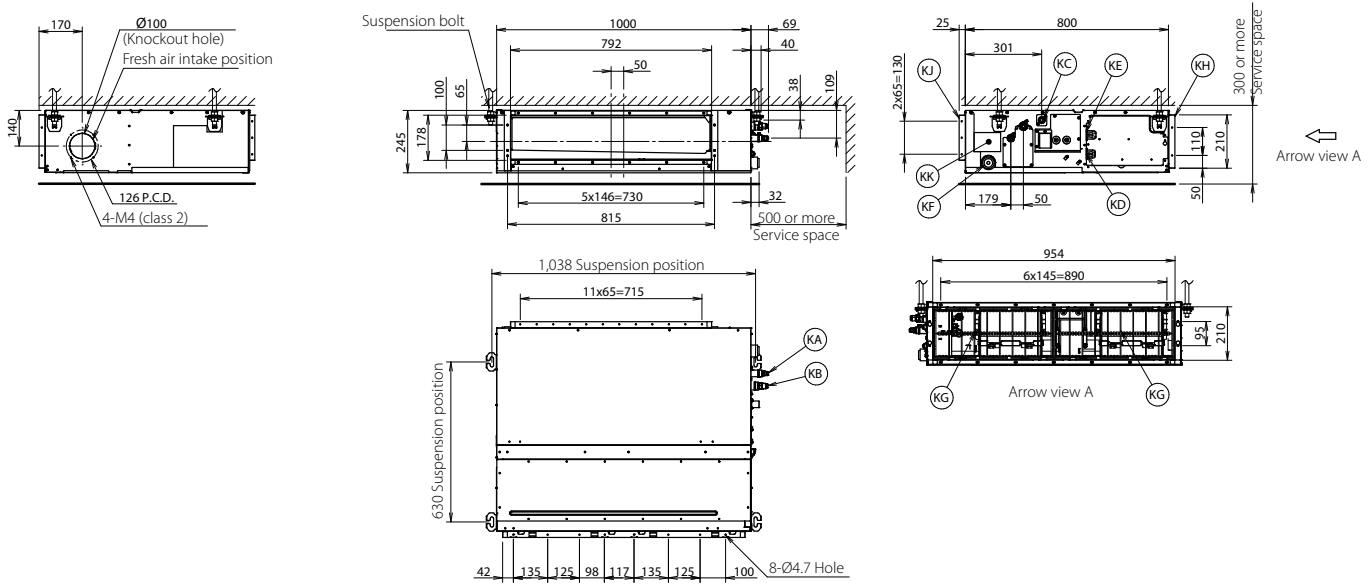

Item	Name	Description
KA	Liquid pipe connection port	ø9.52 flared connection
KB	Gas pipe connection port	ø15.90 flared connection
KC	Drain pipe connection	VP20 (OD ø26, ID ø20)
KD	Wiring connection	/
KE	Power supply connection	/
KF	Drain outlet	VP20 (OD ø26, ID ø20)
KG	Air filter	/
KH	Air suction side	/
KJ	Air discharge side	/
KK	Nameplate	/

NOTES

1. When installing optional accessories, refer to their respective documentation.
2. The ceiling depth varies according to the documentation of the specific system.

3D094915B



ADEA100-125A

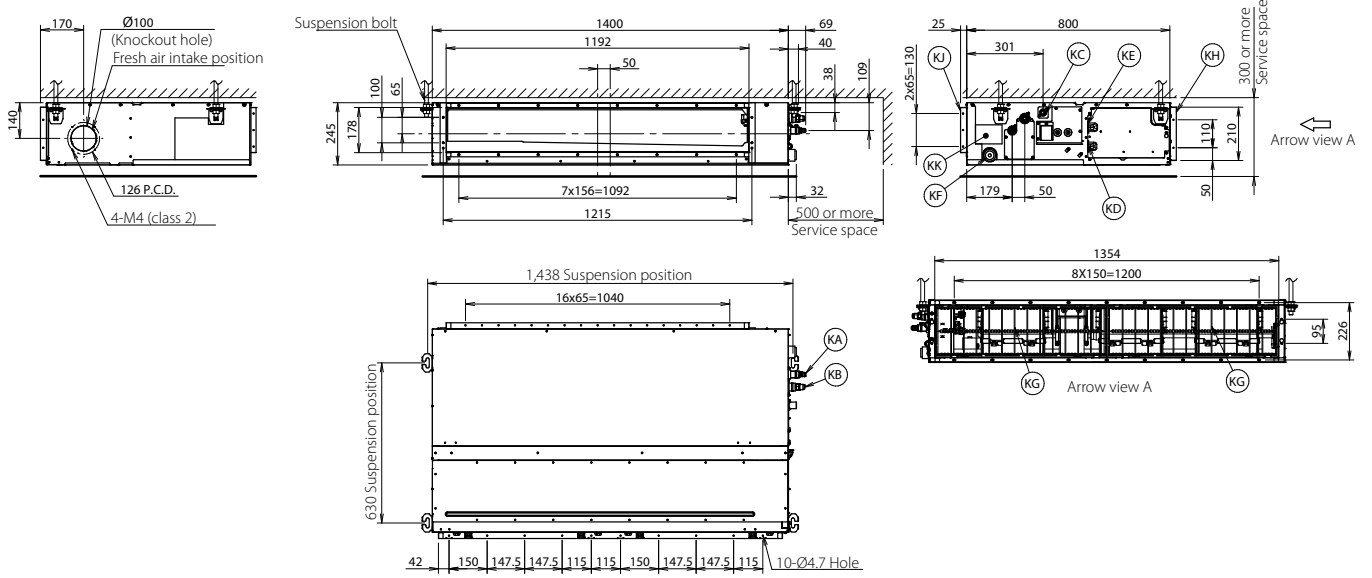

Item	Name	Description
KA	Liquid pipe connection port	ø9.52 flared connection
KB	Gas pipe connection port	ø15.90 flared connection
KC	Drain pipe connection	VP20 (OD ø26, ID ø20)
KD	Wiring connection	/
KE	Power supply connection	/
KF	Drain outlet	VP20 (OD ø26, ID ø20)
KG	Air filter	/
KH	Air suction side	/
KJ	Air discharge side	/
KK	Nameplate	/

NOTES

- When installing optional accessories, refer to their respective documentation.
- The ceiling depth varies according to the documentation of the specific system.

3D094914B

ADEA35-50A

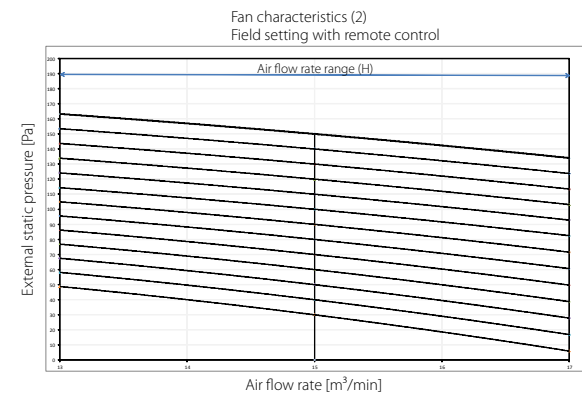
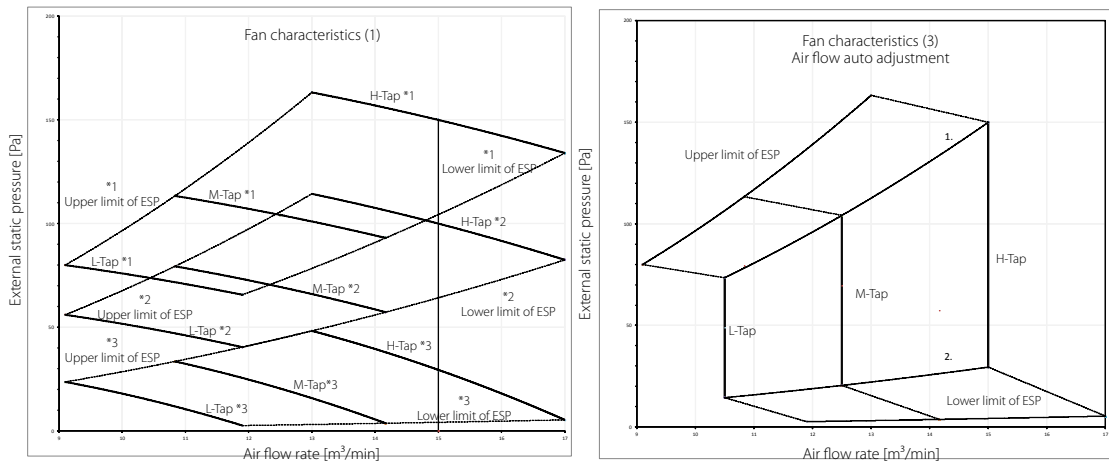

Mark		ESP [Pa]
*1	Maximum	150
*2	-	100
*3	Standard	30

NOTES

- The fan characteristics shown are in "fan only" mode.
- ESP: External Static Pressure

3D095521B

DETAILED TECHNICAL DRAWINGS

ADEA60-71A

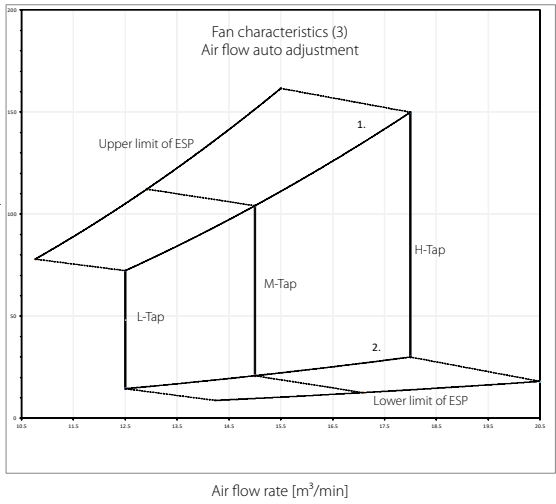
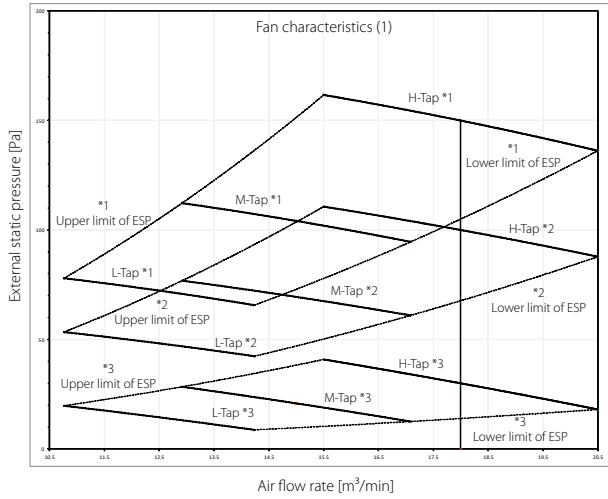

1. Upper limit of ESP by air flow auto adjustment
2. Lower limit of ESP by air flow auto adjustment

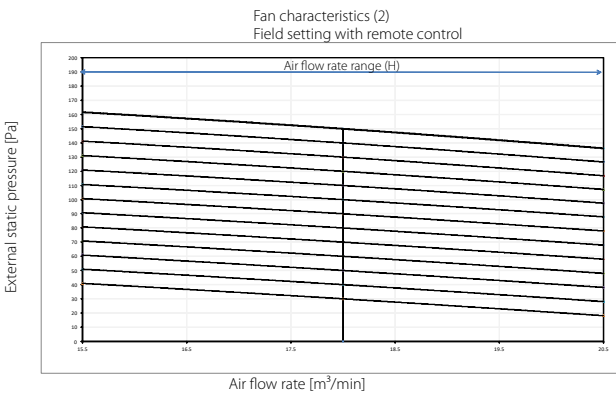

Mark		ESP [Pa]
*1	Maximum	150
*2	-	100
*3	Standard	30

- NOTES**
1. The fan characteristics shown are in "fan only" mode.
 2. ESP: External Static Pressure

3D095524B

ADEA100A

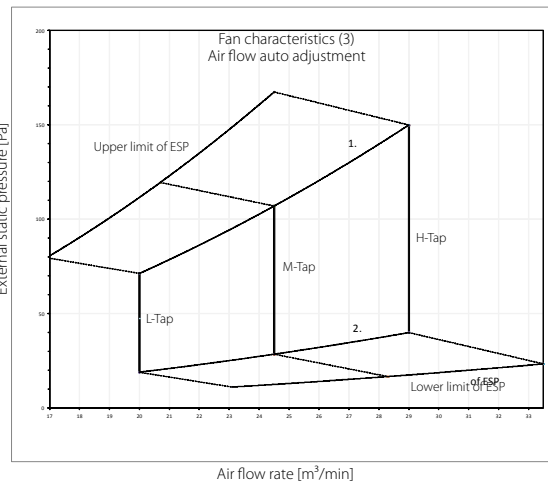
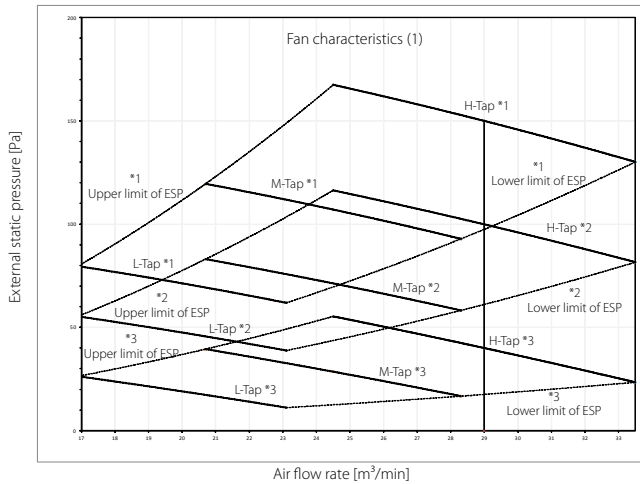

1. Upper limit of ESP by air flow auto adjustment
2. Lower limit of ESP by air flow auto adjustment

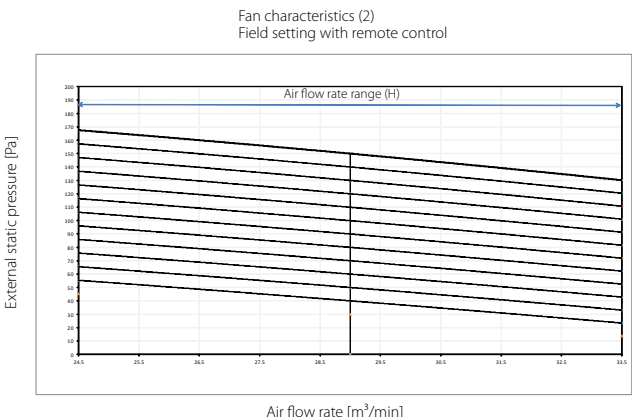

Mark		ESP [Pa]
*1	Maximum	150
*2	-	100
*3	Standard	30

- NOTES**
1. The fan characteristics shown are in "fan only" mode.
 2. ESP: External Static Pressure

3D095526B



ADEA125A

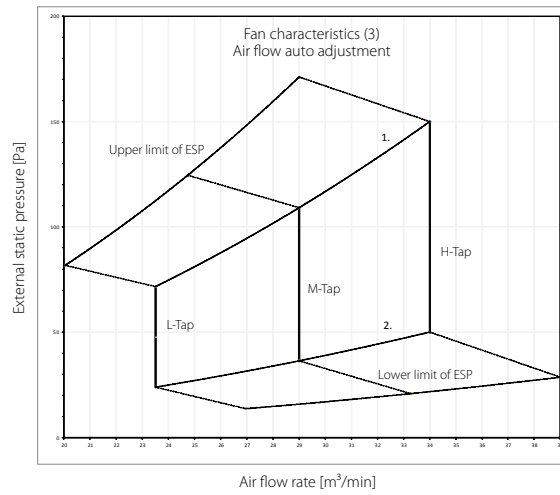
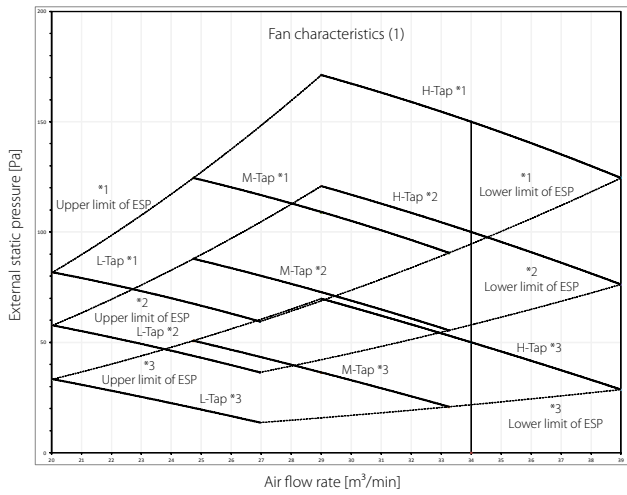

1. Upper limit of ESP by air flow auto adjustment
2. Lower limit of ESP by air flow auto adjustment

Fan characteristics (2)
Field setting with remote control

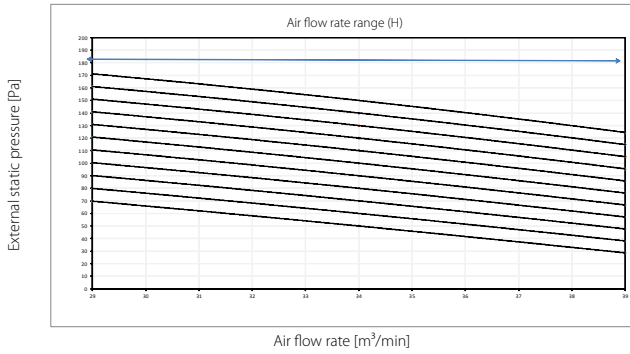

Mark		ESP [Pa]
*1	Maximum	150
*2	-	100
*3	Standard	30

NOTES

1. The fan characteristics shown are in "fan only" mode.
2. ESP: External Static Pressure

3D095527B

DETAILED TECHNICAL DRAWINGS

FAA71B

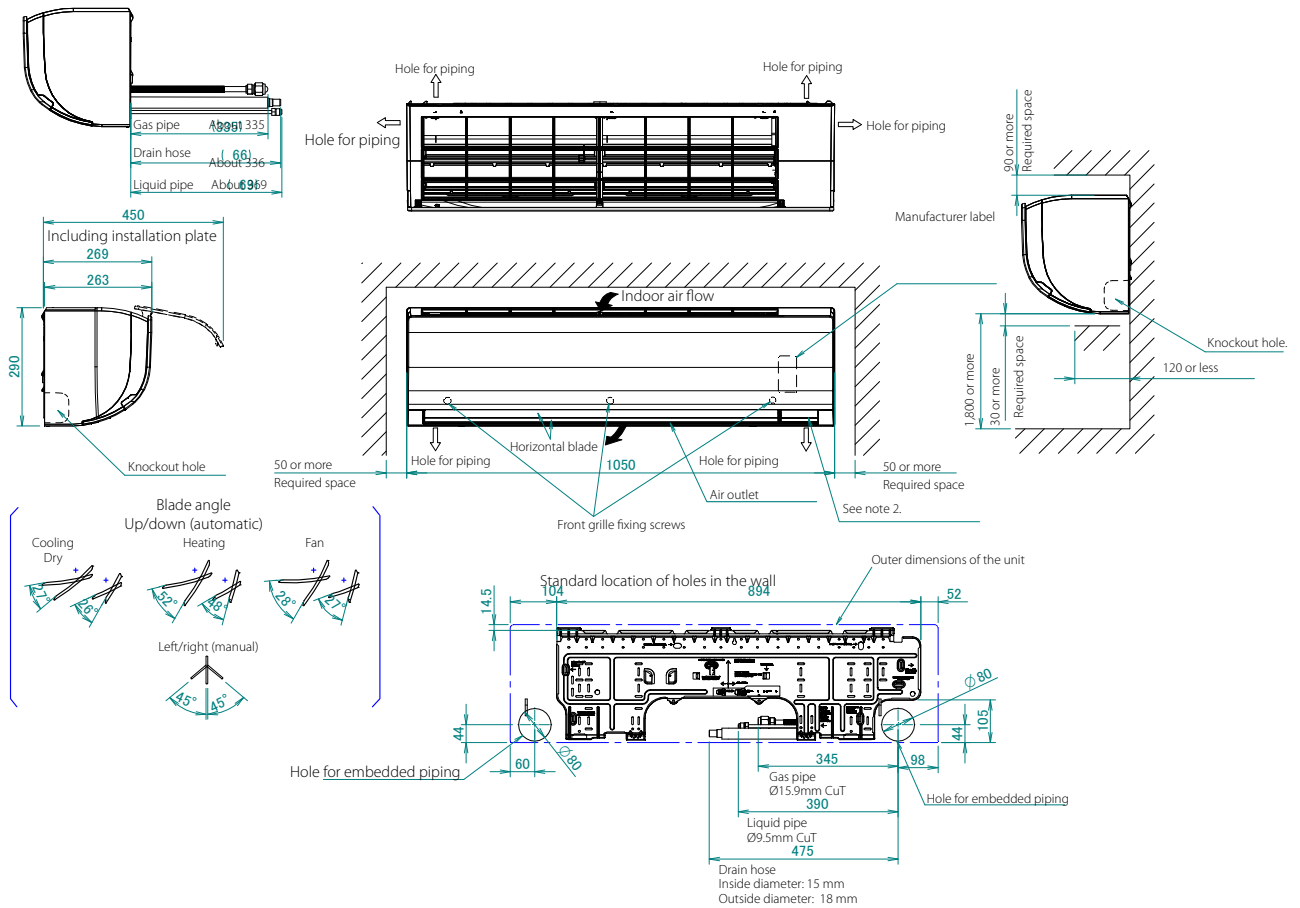

NOTES

1. The mark (➔) shows piping direction
2. When installing a wireless controller, there will be a receiver on this location. For details, see the drawing of the wireless controller.
3. Do not place any objects under the indoor unit. In case of high humidity (>80%), clogged drain outlets, or dirty air filters, condensate may drop out.

3D134459

FAA100B

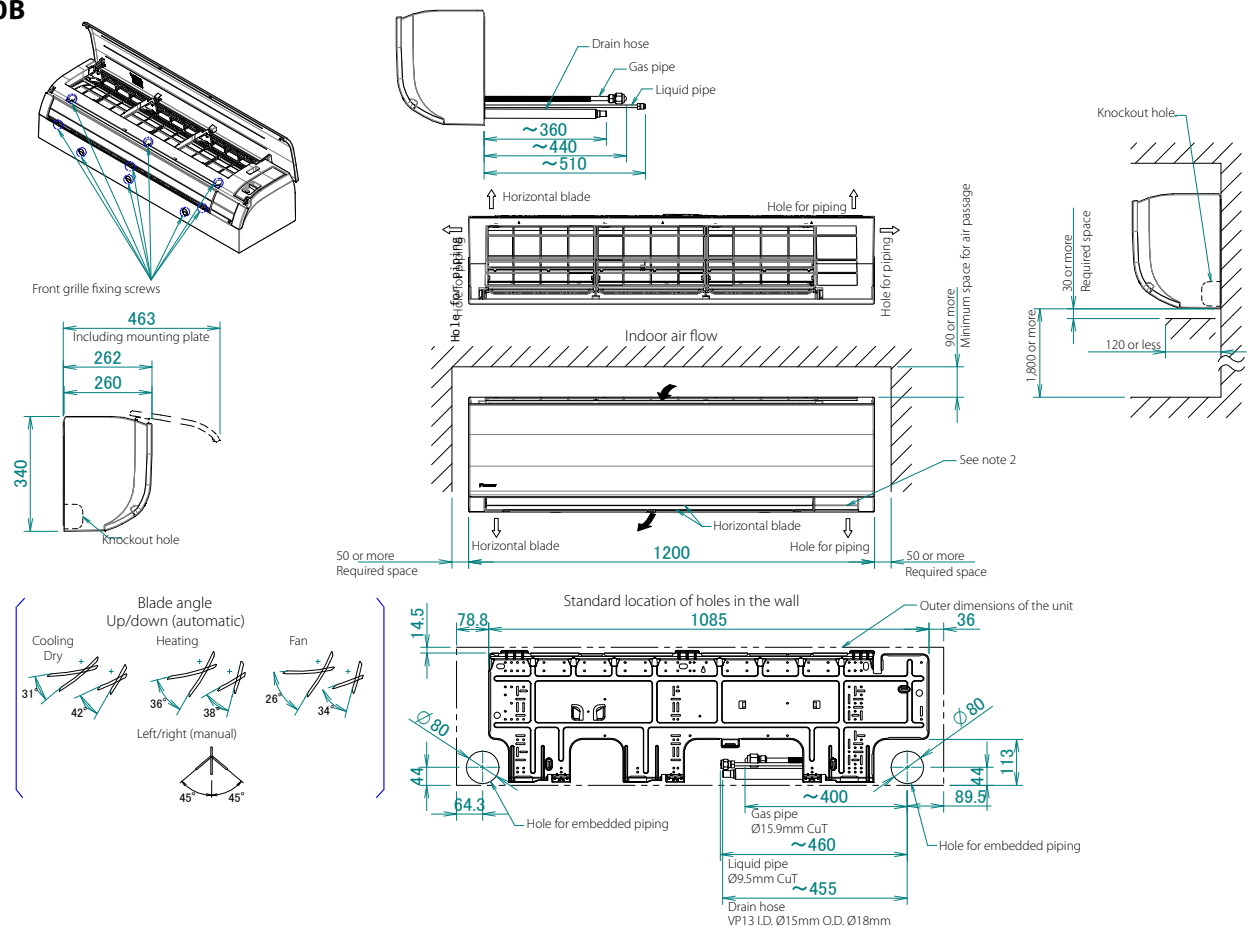

NOTES

1. The mark (➔) shows piping direction
2. When installing a wireless controller, there will be a receiver on this location. For details, see the drawing of the wireless controller.
3. Do not place any objects under the indoor unit. In case of high humidity (>80%), clogged drain outlets, or dirty air filters, condensate may drop out.

3D135741



FAA71B

Air velocity distribution (cooling)

Air flow direction: horizontal

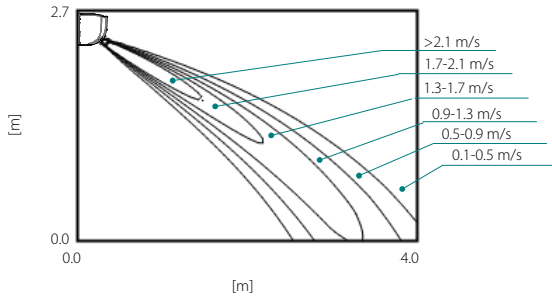

Air temperature distribution (cooling)

Air flow direction: horizontal

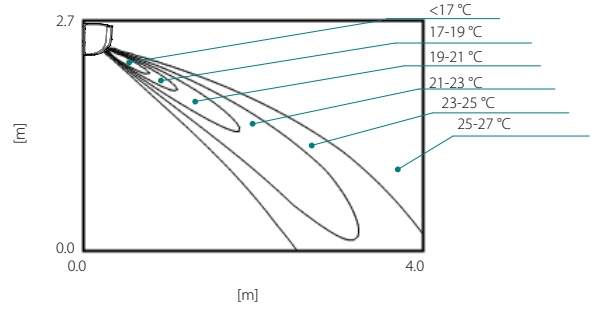

Air velocity distribution (heating)

Air flow direction: vertical

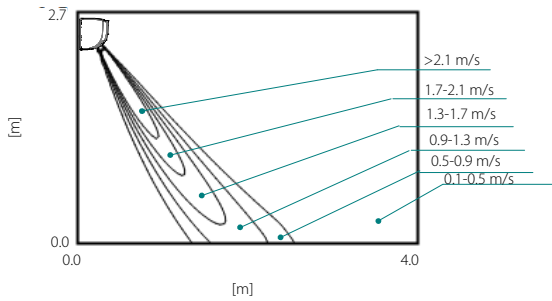

Air temperature distribution (heating)

Air flow direction: vertical

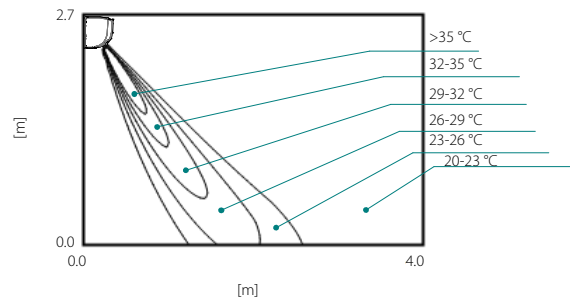

3D137553

FAA100B

Air velocity distribution (cooling)

Air flow direction: horizontal

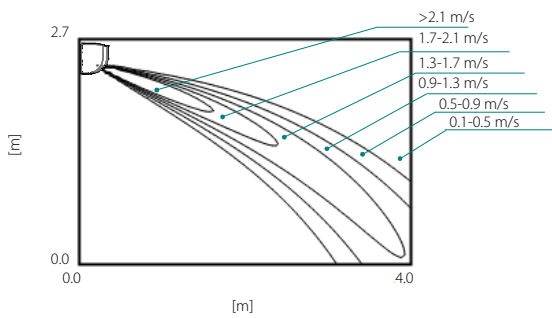

Air temperature distribution (cooling)

Air flow direction: horizontal

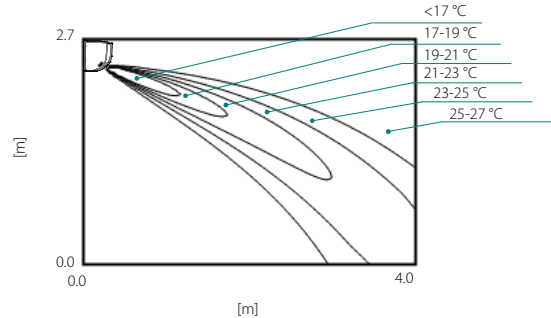

Air velocity distribution (heating)

Air flow direction: vertical

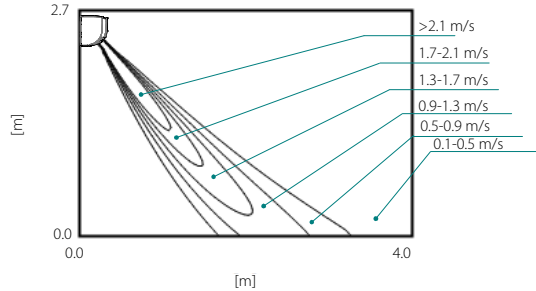

Air temperature distribution (heating)

Air flow direction: vertical

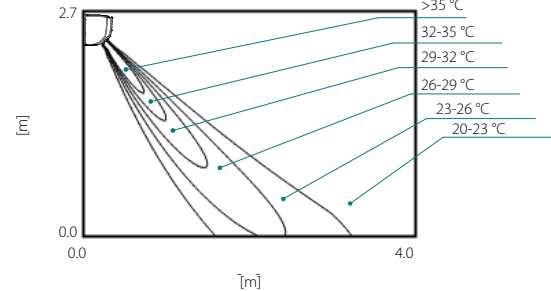

3D137557

DETAILED TECHNICAL DRAWINGS

FHA35A9

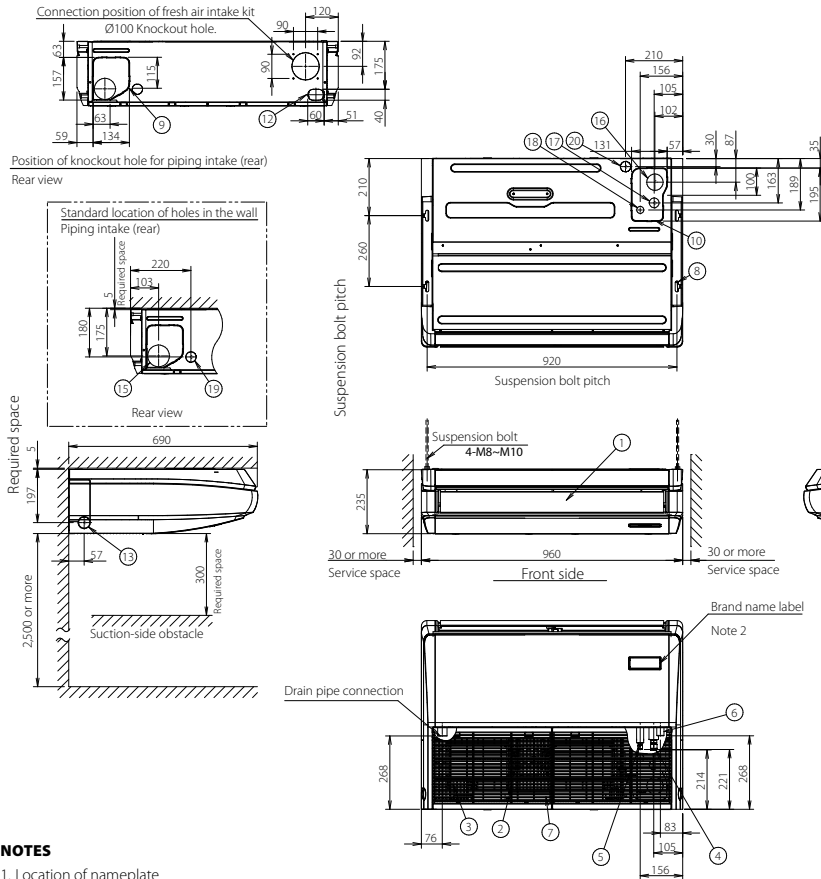

Number	Name	Description
1	Air discharge grille	
2	Air suction grille	
3	Air filter	
4	Gas pipe connection Ø9.5 flare	
5	Liquid pipe connection Ø6.4 flare	
6	Drain pipe connection	VP20
7	Terminal block with earth terminal Located inside of the unit	M4
8	Metal hanger	
9	Position of knockout hole	Rear side
10	Position of knockout hole	Top
11	Piping intake (right)	Knockout hole
12	Drain piping intake (left-rear)	Knockout hole
13	Drain piping intake (left)	Knockout hole
14	Drain piping intake (right)	Knockout hole
15	Standard location of holes in the wall Piping intake (rear)	Ø100
16	Drain piping intake (top)	Ø60
17	Gas piping intake (top)	Ø36
18	Liquid piping intake (top)	Ø26
19	Power supply wiring and control wiring intake (rear)	Ø29
20	Power supply wiring and control wiring intake (top)	Ø29

NOTES

1. Location of nameplate
Bottom of the fan housing inside the suction grille
2. When installing a wireless controller, there will be a receiver on this location. For details, see the drawing of the wireless controller.
3. Do not place any objects under the indoor unit. In case of high humidity (>80%), clogged drain outlets, or dirty air filters, condensate may drop out.

3D106574A

FHA50A9

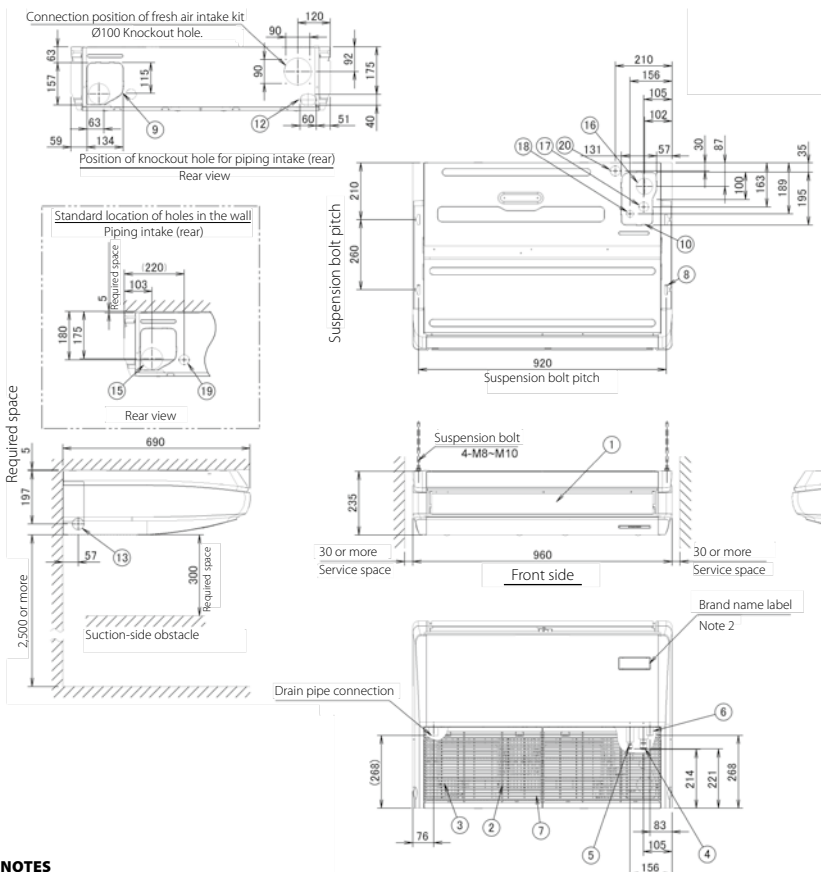

Number	Name	Description
1	Air discharge grille	
2	Air suction grille	
3	Air filter	
4	Gas pipe connection Ø12.7 flare	
5	Liquid pipe connection Ø6.4 flare	
6	Drain pipe connection	VP20
7	Terminal block with earth terminal Located inside of the unit	M4
8	Metal hanger	
9	Position of knockout hole	Rear side
10	Position of knockout hole	Top
11	Piping intake (right)	Knockout hole
12	Drain piping intake (left-rear)	Knockout hole
13	Drain piping intake (left)	Knockout hole
14	Drain piping intake (right)	Knockout hole
15	Standard location of holes in the wall Piping intake (rear)	Ø100
16	Drain piping intake (top)	Ø60
17	Gas piping intake (top)	Ø36
18	Liquid piping intake (top)	Ø26
19	Power supply wiring and control wiring intake (rear)	Ø29
20	Power supply wiring and control wiring intake (top)	Ø29

NOTES

1. Location of nameplate
Bottom of the fan housing inside the suction grille
2. When installing a wireless controller, there will be a receiver on this location. For details, see the drawing of the wireless controller.
3. Do not place any objects under the indoor unit. In case of high humidity (>80%), clogged drain outlets, or dirty air filters, condensate may drop out.

3D109224B



FHA60A9

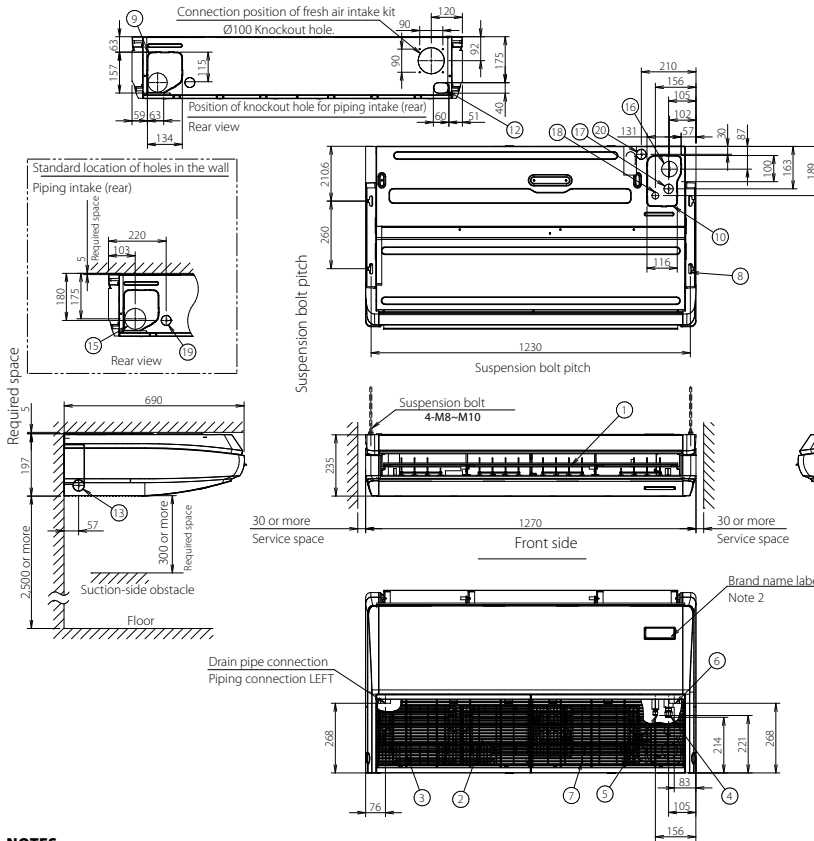

Number	Name	Description
1	Air discharge grille	
2	Air suction grille	
3	Air filter	
4	Gas pipe	Ø12.7 flare
5	Liquid pipe	Ø6.4 flare
6	Drain pipe connection	VP20
7	Terminal block with earth terminal Located inside of the unit	M4
8	Metal hanger	
9	Position of knockout hole	Rear side
10	Position of knockout hole	Top
11	Piping intake (right)	Knockout hole
12	Drain piping intake (left-rear)	Knockout hole
13	Drain piping intake (left)	Knockout hole
14	Drain piping intake (right)	Knockout hole
15	Standard location of holes in the wall Piping intake (rear)	Ø100
16	Drain piping intake (top)	Ø60
17	Gas piping intake (top)	Ø36
18	Liquid piping intake (top)	Ø26
19	Power supply wiring and control wiring intake (rear)	Ø29
20	Power supply wiring and control wiring intake (top)	Ø29

NOTES

1. Location of nameplate
Bottom of the fan housing inside the suction grille
2. When installing a wireless controller, there will be a receiver on this location. For details, see the drawing of the wireless controller.
3. Do not place any objects under the indoor unit. In case of high humidity (>80%), clogged drain outlets, or dirty air filters, condensate may drop out.

3D106552

FHA71A9

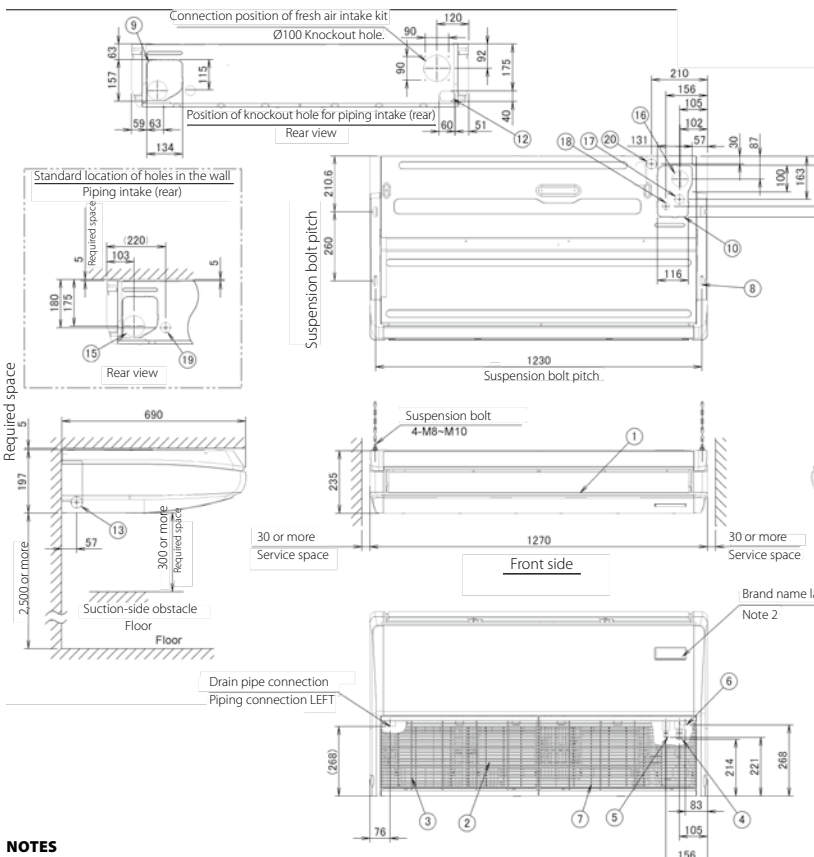

Number	Name	Description
1	Air discharge grille	
2	Air suction grille	
3	Air filter	
4	Gas pipe	Ø15.9 flare
5	Liquid pipe	Ø9.5 flare
6	Drain pipe connection	VP20
7	Terminal block with earth terminal Located inside of the unit	M4
8	Metal hanger	
9	Position of knockout hole	Rear side
10	Position of knockout hole	Top
11	Piping intake (right)	Knockout hole
12	Drain piping intake (left-rear)	Knockout hole
13	Drain piping intake (left)	Knockout hole
14	Drain piping intake (right)	Knockout hole
15	Standard location of holes in the wall Piping intake (rear)	Ø100
16	Drain piping intake (top)	Ø60
17	Gas piping intake (top)	Ø36
18	Liquid piping intake (top)	Ø26
19	Power supply wiring and control wiring intake (rear)	Ø29
20	Power supply wiring and control wiring intake (top)	Ø29

NOTES

1. Location of nameplate
Bottom of the fan housing inside the suction grille
2. When installing a wireless controller, there will be a receiver on this location. For details, see the drawing of the wireless controller.
3. Do not place any objects under the indoor unit. In case of high humidity (>80%), clogged drain outlets, or dirty air filters, condensate may drop out.

3D109222A

DETAILED TECHNICAL DRAWINGS

FHA100-140A

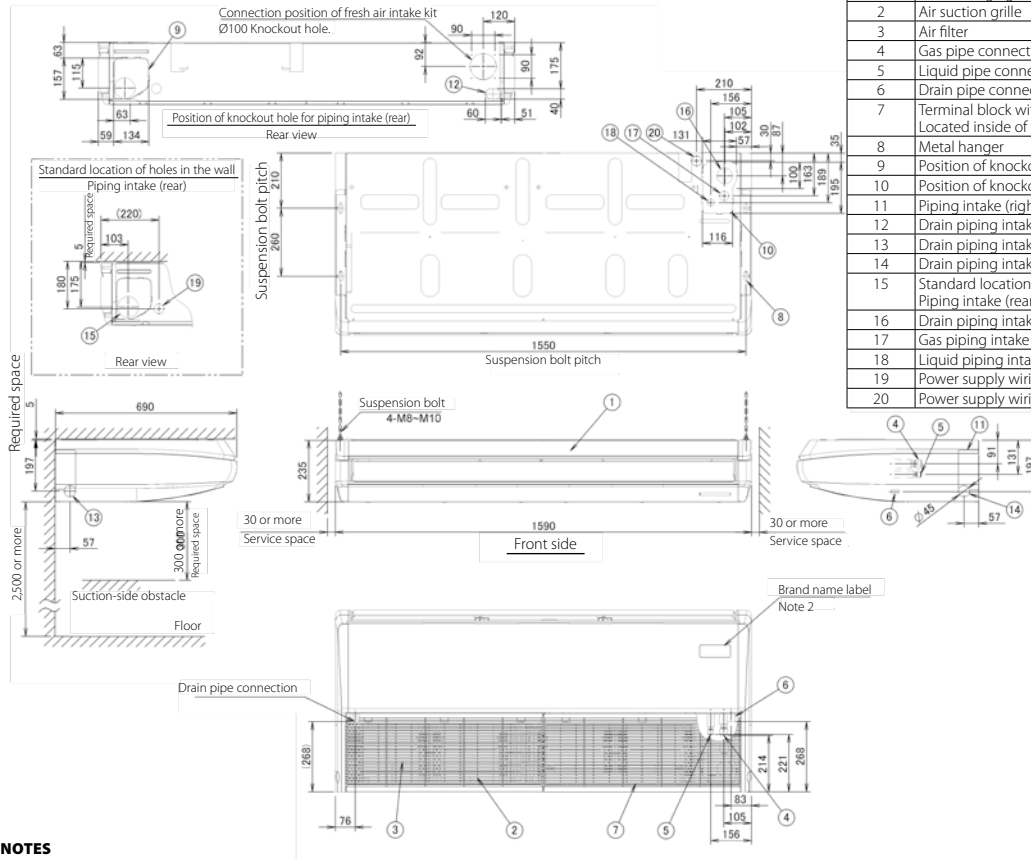

Number	Name	Description
1	Air discharge grille	
2	Air suction grille	
3	Air filter	
4	Gas pipe connection	Ø15.9 flare
5	Liquid pipe connection	Ø9.5 flare
6	Drain pipe connection	VP20
7	Terminal block with earth terminal	Located inside of the unit M4
8	Metal hanger	
9	Position of knockout hole	Rear side
10	Position of knockout hole	Top
11	Piping intake (right)	Knockout hole
12	Drain piping intake (left-rear)	Knockout hole
13	Drain piping intake (left)	Knockout hole
14	Drain piping intake (right)	Knockout hole
15	Standard location of holes in the wall	Ø100 Piping intake (rear)
16	Drain piping intake (top)	Ø60
17	Gas piping intake (top)	Ø36
18	Liquid piping intake (top)	Ø26
19	Power supply wiring and control wiring intake (rear)	Ø29
20	Power supply wiring and control wiring intake (top)	Ø29

NOTES

1. Location of nameplate
Bottom of the fan housing inside the suction grille
2. When installing a wireless controller, there will be a receiver on this location. For details, see the drawing of the wireless controller.
3. Do not place any objects under the indoor unit. In case of high humidity (>80%), clogged drain outlets, or dirty air filters, condensate may drop out.

3D106530B



FUA-A

When closing the air outlet, the required space is 30mm or more. Note (3)

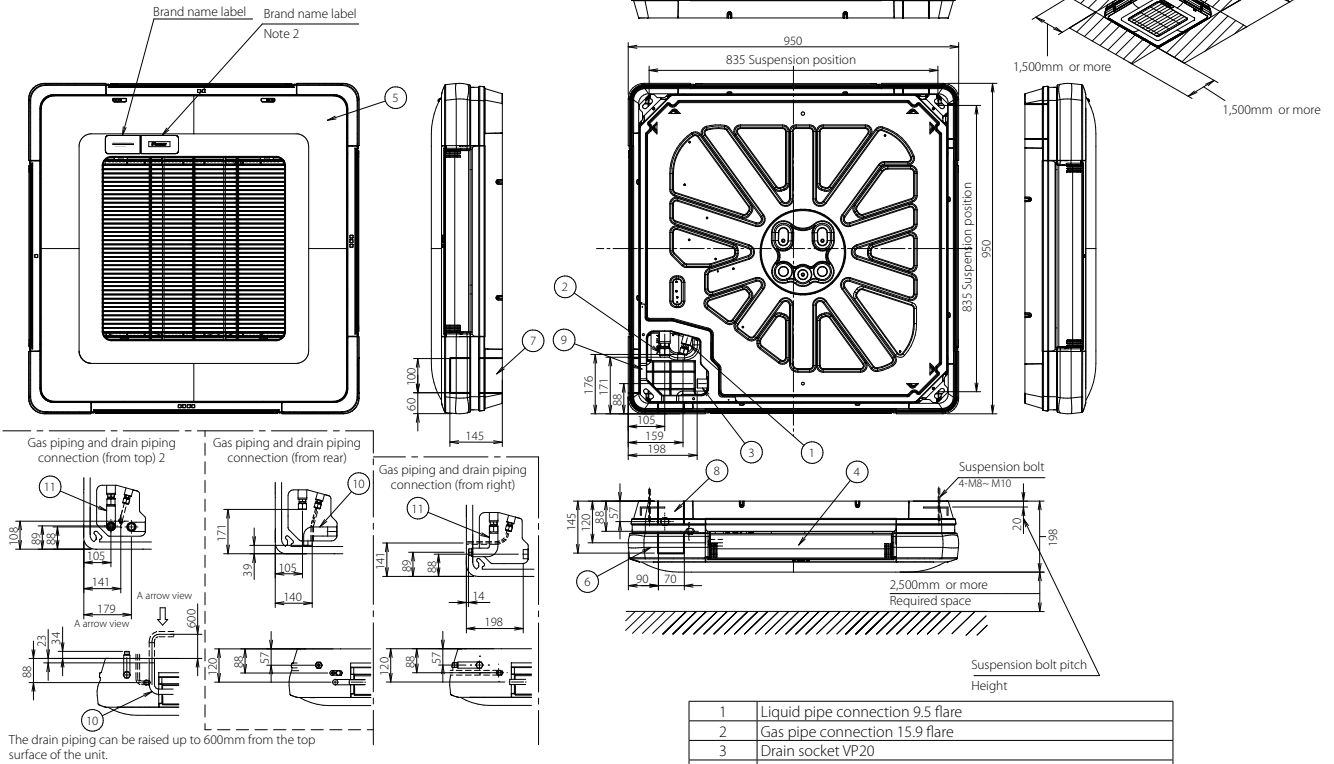

NOTES

1. The unit nameplate is located on the control box cover.
2. When installing a wireless controller, there will be a receiver on this location. For details, see the drawing of the wireless controller.
3. When closing the discharge grille in case of 2-way blow or 3-way blow, there are limitations to the piping connection direction. See the installation manual.
4. Do not place any objects under the indoor unit. In case of high humidity (>80%), clogged drain outlets, or dirty air filters, condensate may drop out.

1	Liquid pipe connection 9.5 flare
2	Gas pipe connection 15.9 flare
3	Drain socket VP20
4	Air discharge outlet
5	Air suction grille
6	Corner decoration cover
7	Piping connection right/ Wiring connection
8	Piping connection Rear/ Wiring connection
9	Pipe cover (top)
10	Drain pipe connection (outside diameter 26)
11	L-type piping kit (upward direction) 15.9 flared connection

3D106356

DETAILED TECHNICAL DRAWINGS

FVA71A

This unit has to be fixed with fixing screws as shown below.
 In case of fixing it at the bottom
 In case vibration resistance is required, fix it at both the bottom and the rear.

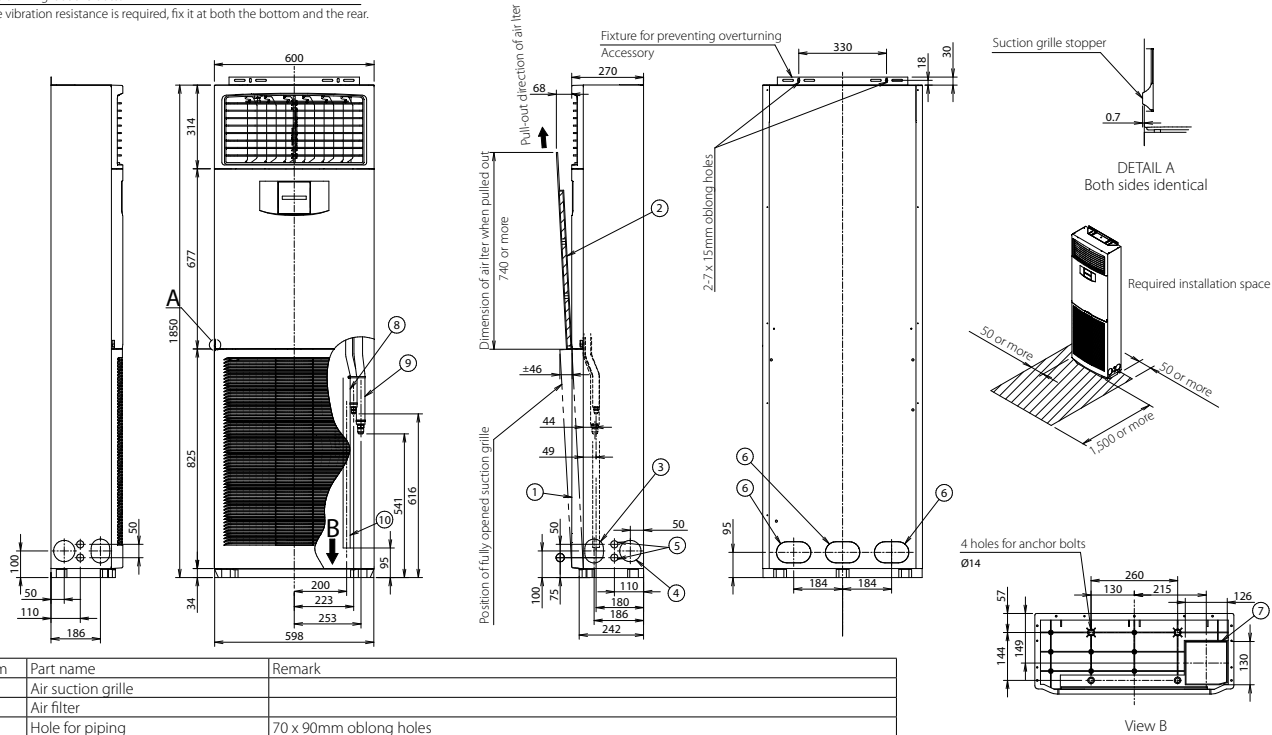

Item	Part name	Remark
1	Air suction grille	
2	Air filter	
3	Hole for piping	70 x 90mm oblong holes
4	Hole for piping	Knockout hole for recirculation piping or wiring of optional equipment Ø80
5	Hole for piping	Knockout hole for recirculation piping or wiring of optional equipment Ø27
6	Piping hole (rear)	80 x 130mm oblong holes
7	Piping hole (bottom)	126 x 130mm oblong holes
8	Liquid pipe	Ø9.5 flared connection
9	Gas pipe	Ø15.9 flared connection
10	Drain pipe connection	VP20

NOTES

1. The unit nameplate is located on the switch box cover, inside the suction grille.

3D110397

FVA100-125-140A

This unit has to be fixed with fixing screws as shown below.
 In case of fixing it at the bottom
 In case vibration resistance is required, fix it at both the bottom and the rear.

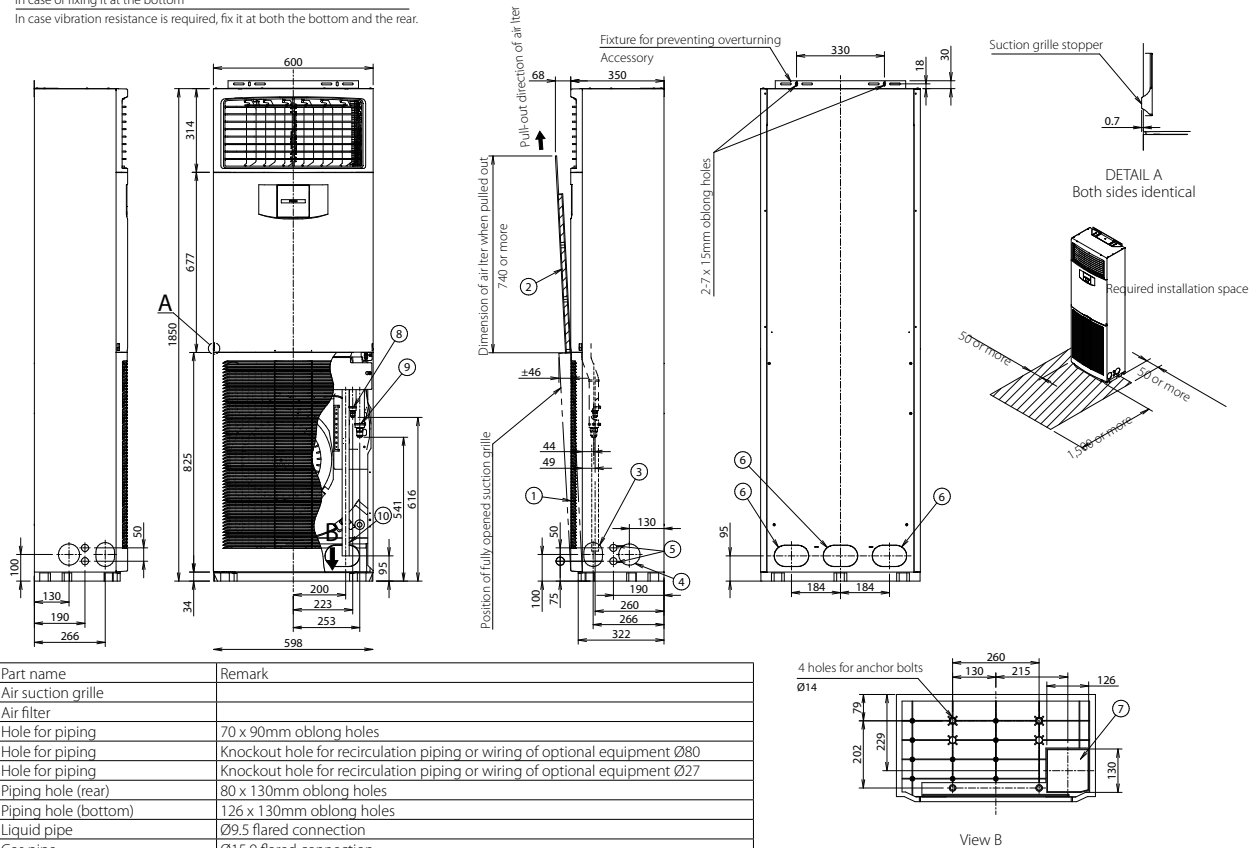

Item	Part name	Remark
1	Air suction grille	
2	Air filter	
3	Hole for piping	70 x 90mm oblong holes
4	Hole for piping	Knockout hole for recirculation piping or wiring of optional equipment Ø80
5	Hole for piping	Knockout hole for recirculation piping or wiring of optional equipment Ø27
6	Piping hole (rear)	80 x 130mm oblong holes
7	Piping hole (bottom)	126 x 130mm oblong holes
8	Liquid pipe	Ø9.5 flared connection
9	Gas pipe	Ø15.9 flared connection
10	Drain pipe connection	VP20

NOTES

1. The unit nameplate is located on the switch box cover, inside the suction grille.

3D110703



FNA25-35A9

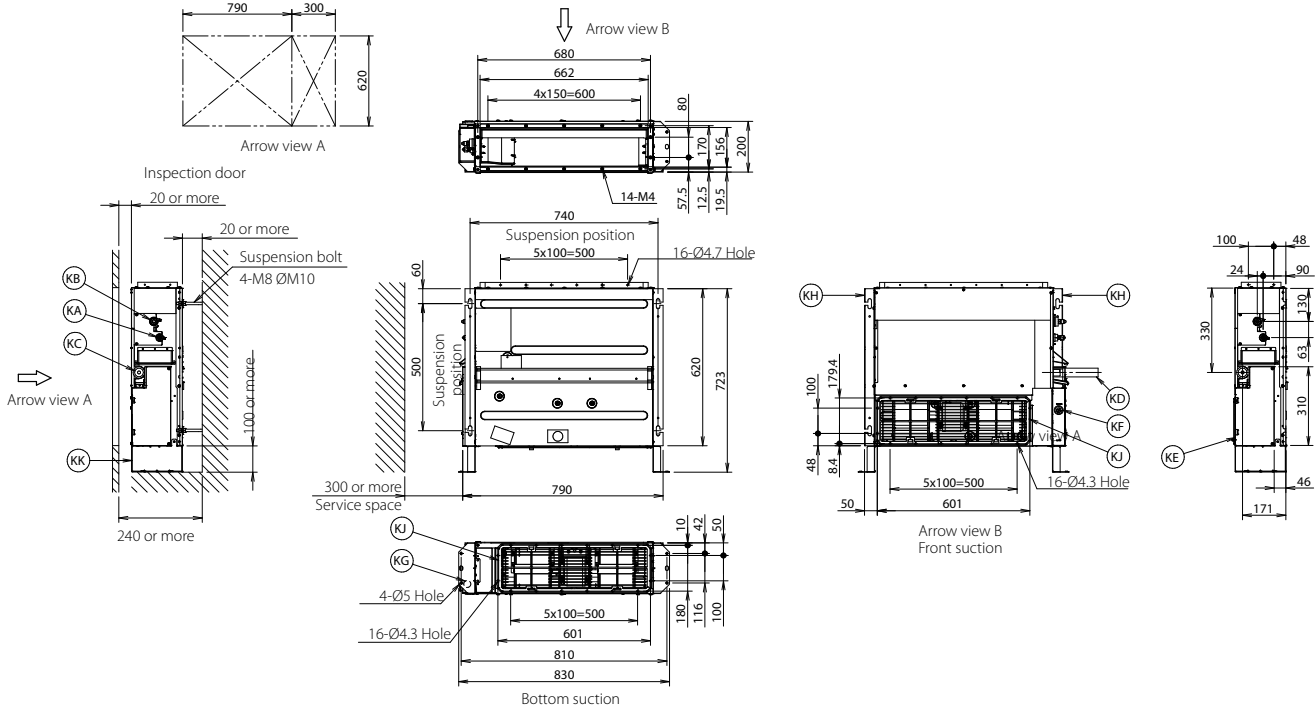

Item	Name	Description
KA	Liquid pipe connection port	Ø6.40 flared connection
KB	Gas pipe connection port	Ø9.50 flared connection
KC	Drain pipe connection	VP20 (OD Ø26, ID Ø20)
KD	Drain hose	ID Ø25
KE	Control box	/
KF	Transmission line	/
KG	Power supply connection	/
KH	Suspension bracket	/
KJ	Air filter	/
KK	Mounting foot	/

NOTES

1. When installing optional accessories, refer to their respective documentation.
2. The ceiling depth varies according to the documentation of the specific system.

3D112885

FNA50-60A9

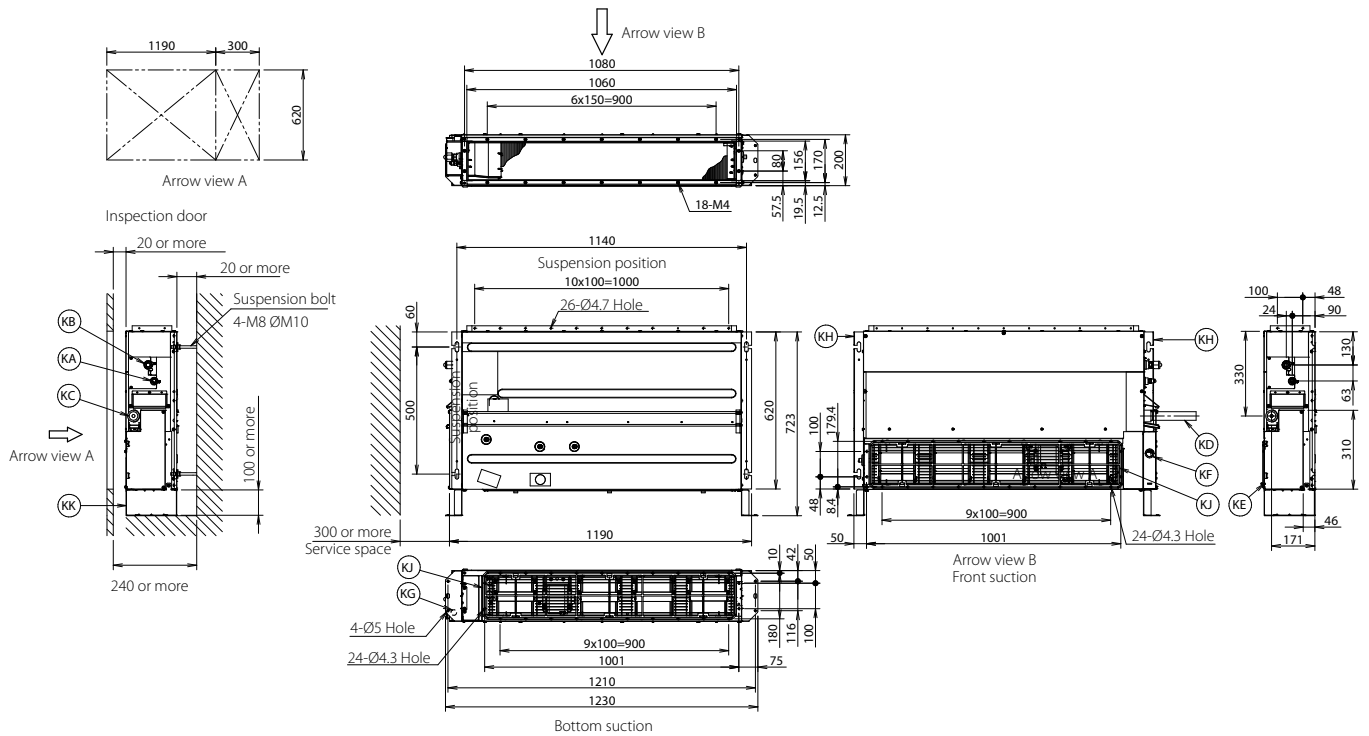

Item	Name	Description
KA	Liquid pipe connection port	Ø6.4 flared connection
KB	Gas pipe connection port	Ø12.70 flared connection
KC	Drain pipe connection	VP20 (OD Ø26, ID Ø20)
KD	Drain hose	ID Ø25
KE	Control box	/
KF	Transmission line	/
KG	Power supply connection	/
KH	Suspension bracket	/
KJ	Air filter	/
KK	Mounting foot	/

NOTES

1. When installing optional accessories, refer to their respective documentation.
2. The ceiling depth varies according to the documentation of the specific system.

3D112884

FNA25-35A9

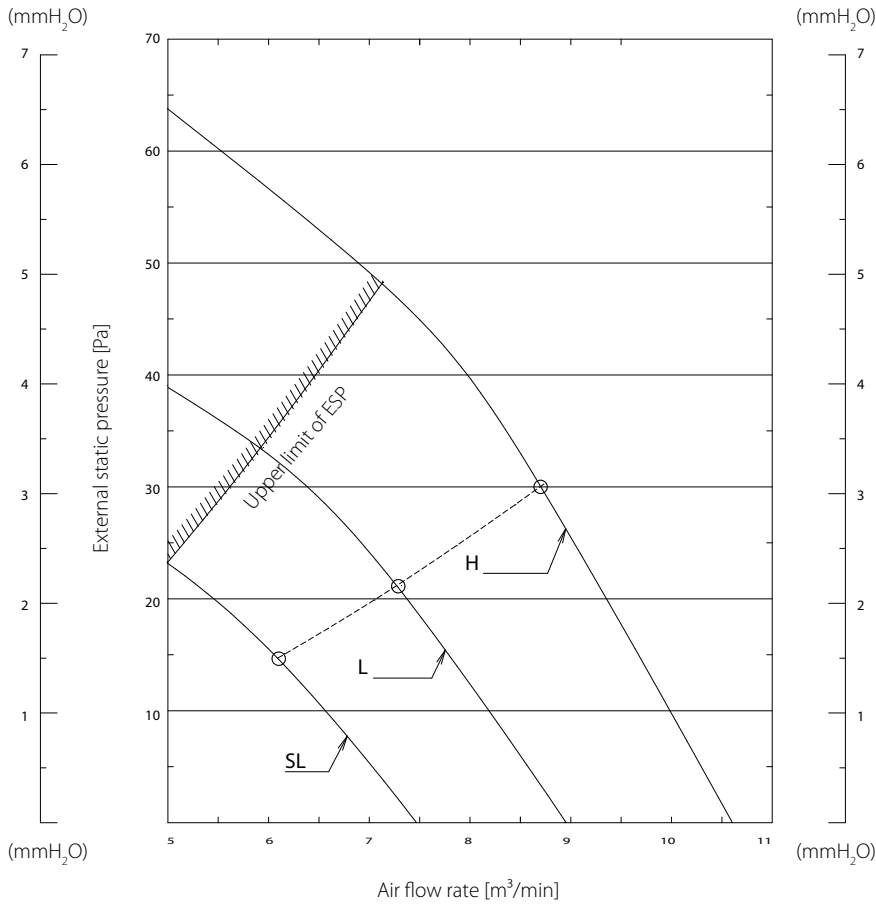

3D081327C

FNA50A9

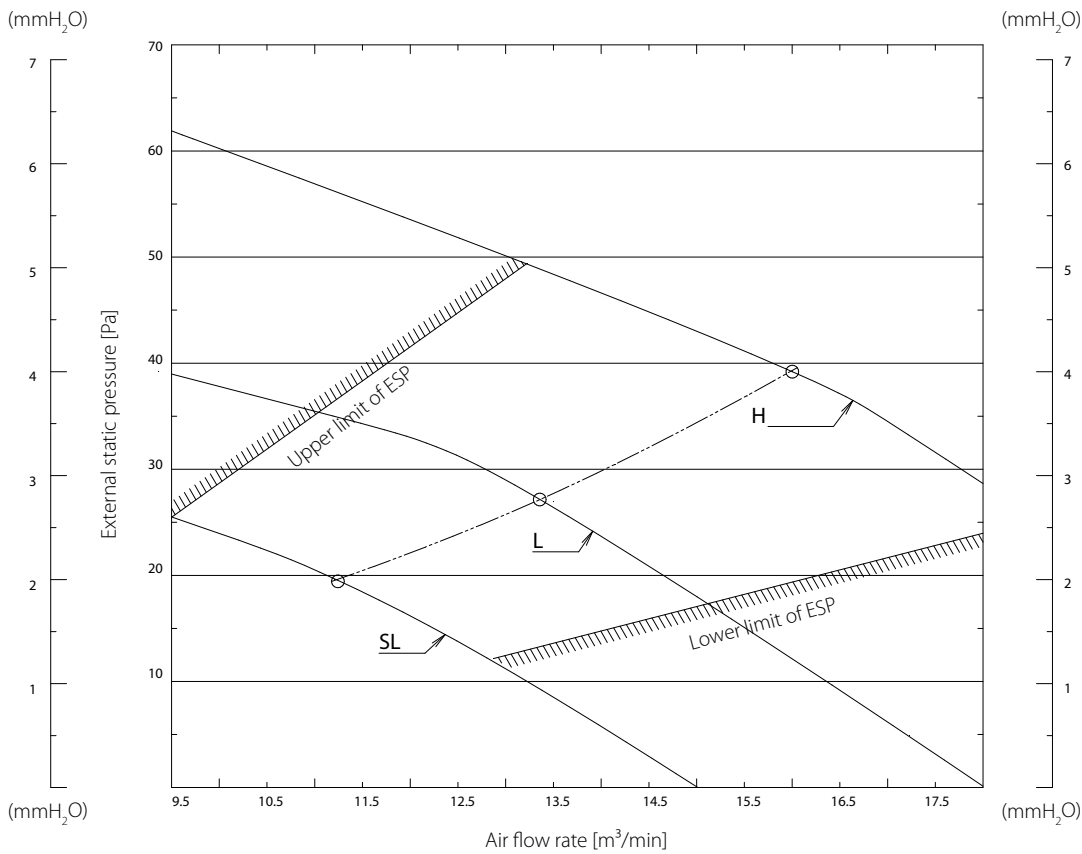

3D085960C



FNA60A9

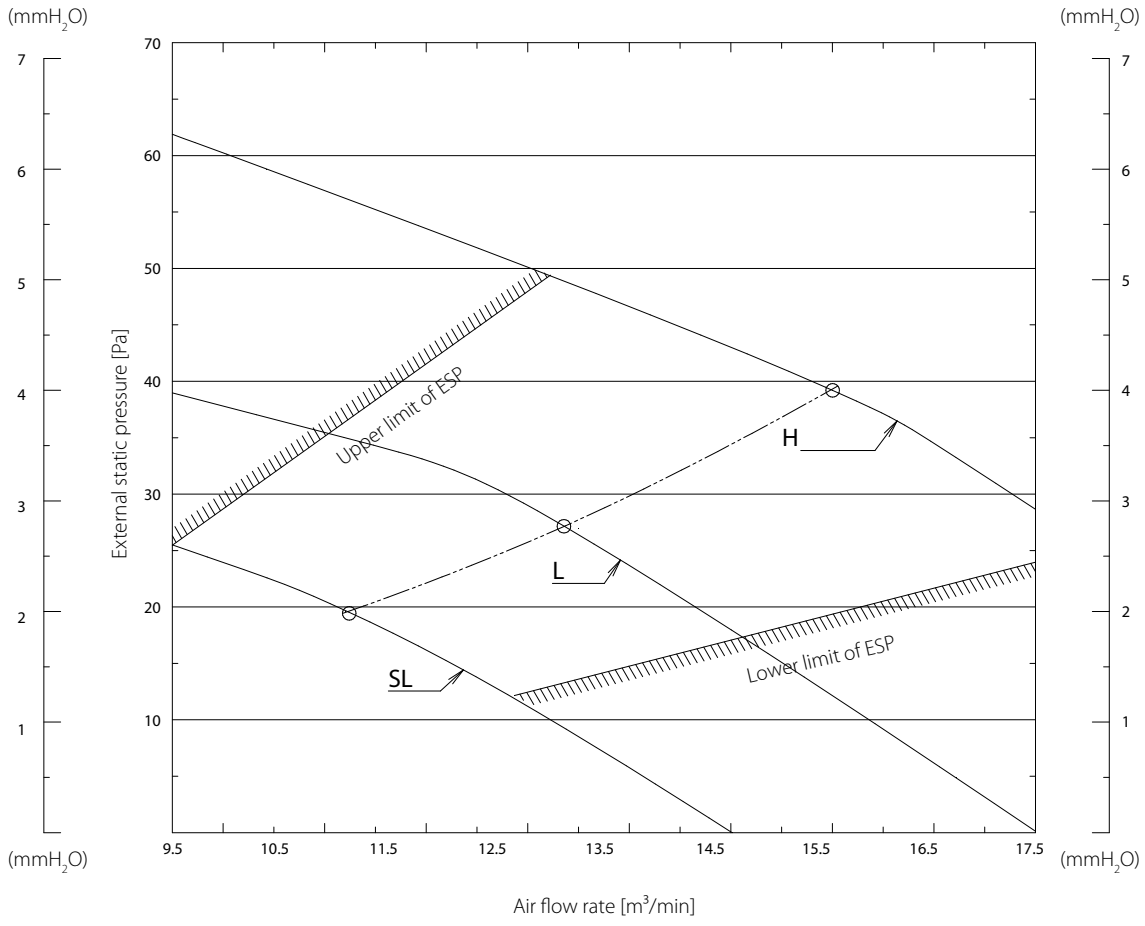

3D081329C



Technical drawings

Outdoor units

RZAG-A	197
RZAG-NV1/NY1	200
RZASG-MV1/MY1	209
RZASG-MV/MY	216
RZA-D	222
AZAS-MV/MY	227
RXM-R(9)/A / ARXM-R	232

DETAILED TECHNICAL DRAWINGS

RZAG60A

Unit combination restrictions		Power supply		Compressor		OFM		IFM				
Outdoor unit	Indoor unit	Hz	Voltage	Voltage range	MCA	MFA	RHz	RLA	kW	FLA	kW	FLA
RZAG60A2V1B	FDXM60F3V1B9	50	220	MAX. 50Hz 264V MIN. 50Hz 198V	17.10	20	70	7.3	0.058	0.38	0.060	0.9
		50	230					6.9				
		50	240					6.7				
RZAG60A2V1B	FFA60A2VEB9	50	220	MAX. 50Hz 264V MIN. 50Hz 198V	16.70	20	70	9.0	0.058	0.38	0.050	0.6
		50	230					8.6				
		50	240					8.2				
RZAG60A2V1B	FBA60A2VEB9	50	220	MAX. 50Hz 264V MIN. 50Hz 198V	17.40	20	65	7.0	0.058	0.38	0.070	1.3
		50	230					6.7				
		50	240					6.4				
RZAG60A2V1B	FCAG60BVEB	50	220	MAX. 50Hz 264V MIN. 50Hz 198V	16.40	20	72	7.5	0.058	0.38	0.048	0.3
		50	230					7.2				
		50	240					6.9				
RZAG60A2V1B	FNA60A2VEB9	50	220	MAX. 50Hz 264V MIN. 50Hz 198V	16.70	20	70	9.0	0.058	0.38	0.060	0.6
		50	230					8.6				
		50	240					8.3				
RZAG60A2V1B	FTXM60N2V1B	50	220	MAX. 50Hz 264V MIN. 50Hz 198V	16.70	20	71	8.4	0.058	0.38	0.046	0.6
		50	230					8.1				
		50	240					7.7				
RZAG60A2V1B	FHA60AVEB98	50	220	MAX. 50Hz 264V MIN. 50Hz 198V	16.70	20	67	8.1	0.058	0.38	0.091	0.6
		50	230					7.7				
		50	240					7.4				
RZAG60A2V1B	FBA71A2VEB9	50	220	MAX. 50Hz 264V MIN. 50Hz 198V	17.40	20	65	8.9	0.058	0.38	0.070	1.3
		50	230					8.5				
		50	240					8.1				
RZAG60A2V1B	FCAG71BVEB	50	220	MAX. 50Hz 264V MIN. 50Hz 198V	16.40	20	72	7.5	0.058	0.38	0.054	0.3
		50	230					7.2				
		50	240					6.9				
RZAG60A2V1B	FTXM71N2V1B	50	220	MAX. 50Hz 264V MIN. 50Hz 198V	16.70	20	71	8.4	0.058	0.38	0.052	0.6
		50	230					8.0				
		50	240					7.7				
RZAG60A2V1B	FHA71AVEB98	50	220	MAX. 50Hz 264V MIN. 50Hz 198V	16.90	20	67	8.1	0.058	0.38	0.110	0.8
		50	230					7.7				
		50	240					7.4				
RZAG60A2V1B	FTXM60R2V1B	50	220	MAX. 50Hz 264V MIN. 50Hz 198V	16.70	20	71	8.4	0.058	0.38	0.046	0.6
		50	230					8.1				
		50	240					7.7				
RZAG60A2V1B	FTXM71R2V1B	50	220	MAX. 50Hz 264V MIN. 50Hz 198V	16.70	20	71	8.4	0.058	0.38	0.052	0.6
		50	230					8.0				
		50	240					7.7				

3D118441D

RZAG-A

Symbols	Notes
MCA Minimum Circuit Ampere [A]	1 The RLA is based on the following conditions. Outdoor temperature 35°C DB Indoor temperature 27°C DB / 19°C WB 2 Select the wire size according to the MCA. 3 The maximum allowable voltage that is unbalanced between phases is 2%. 4 Use a circuit breaker instead of a fuse.
MFA Maximum Fuse Ampere [A]	
RLA Rated load amps [A]	
OFM Outdoor fan motor	
IFM Indoor fan motor	
FLA Full Load Ampere [A]	
kW Fan motor rated output [kW]	
RHz Rated operating frequency [Hz]	

3D118439E - 3D118440D - 3D118441D



RZAG35A

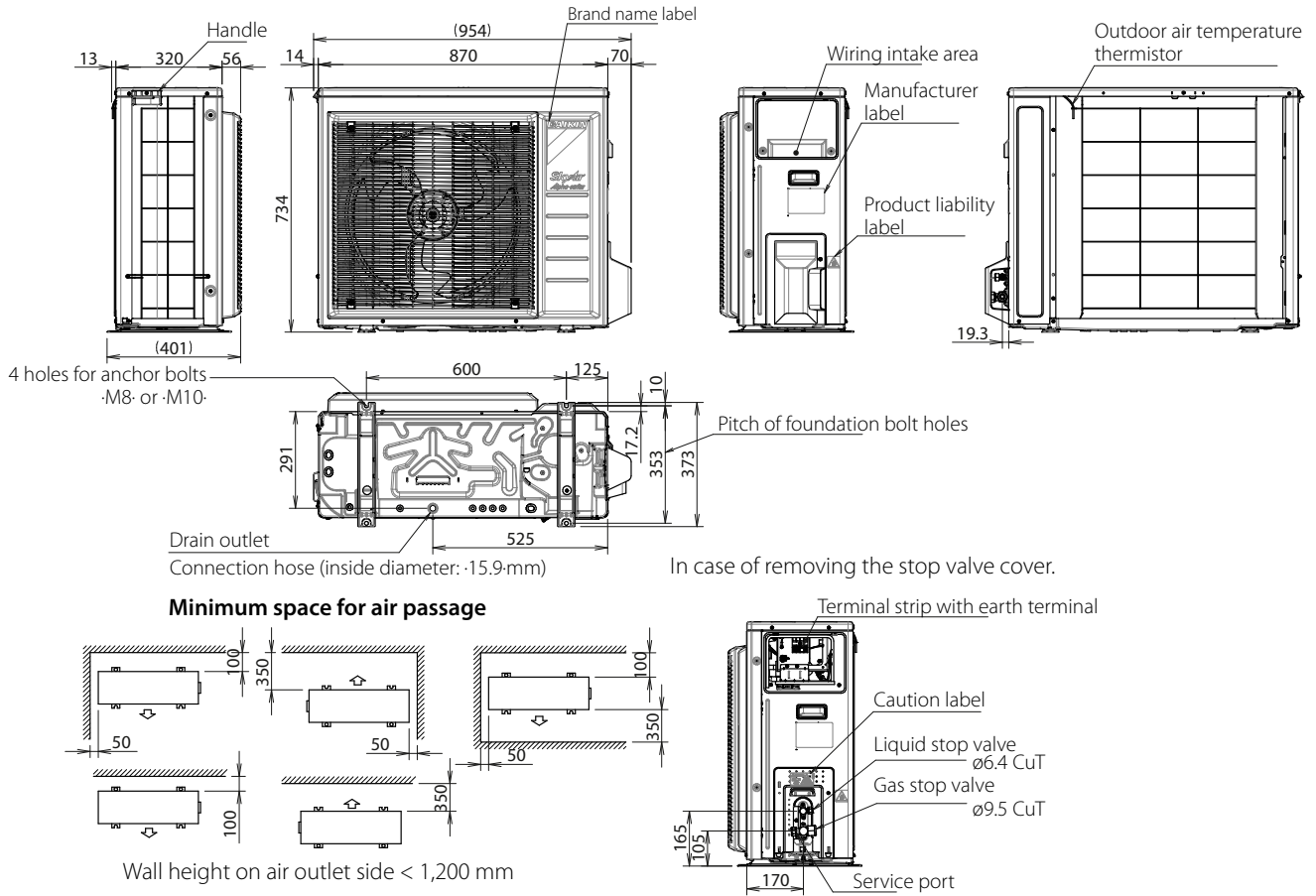

3D118381A

RZAG50-60A

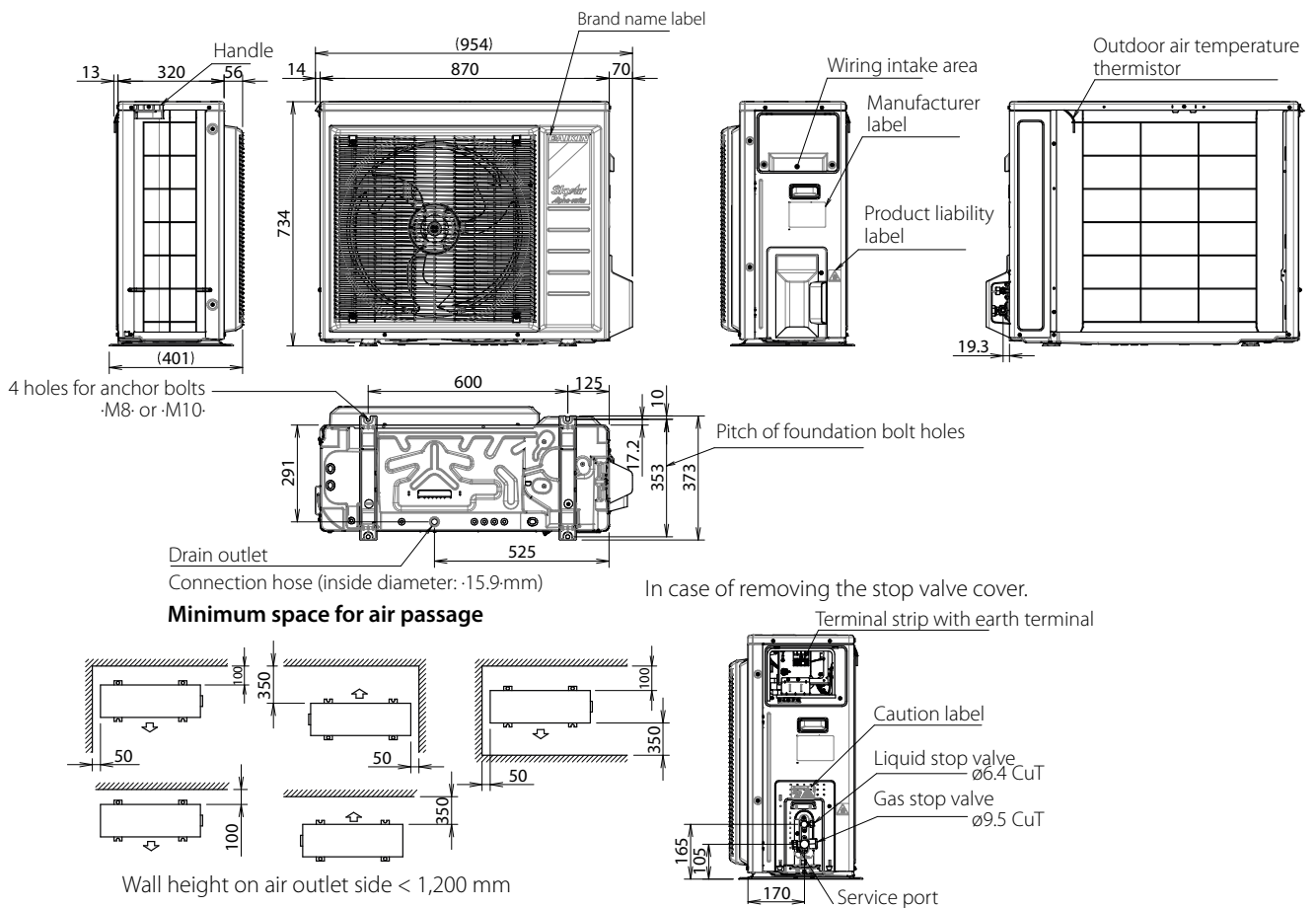

3D118380A



DETAILED TECHNICAL DRAWINGS

RZAG-NV1/NY1

Symbols			Notes
MCA	Minimum Circuit Ampere	[A]	1 The -RLA- is based on the following conditions. Cooling Indoor temperature -27.0°C DB / -19.0°C WB Outdoor temperature -35.0°C DB Heating Indoor temperature -20.0°C DB Outdoor temperature -7.0°C DB / -6.0°C WB
TOCA	Total overcurrent amps	[A]	
MFA	Maximum Fuse Ampere	[A]	
MSC	Maximum current of the starting compressor	[A]	
RLA	Rated load amps	[A]	
OFM	Outdoor fan motor		
IFM	Indoor fan motor		
FLA	Full Load Ampere	[A]	
kW	Fan motor rated output	[kW]	
			3 Voltage range The units are suitable for use with electrical systems in which the voltage supplied to the unit terminals is not below or above the listed range limits.
			4 The maximum allowable voltage that is unbalanced between phases is -2%.
			5 -MCA- is the maximum input current. The capacity of the -MFA- must be greater than that of the -MCA-. Select the -MFA- according to the table.
			6 Select the wire size according to the MCA.
			7 -MFA- is used to select the circuit breaker and the ground fault circuit interruptor. Earth leakage circuit breaker

3D120943E

RZAG71-100NV1 INFRASTRUCTURE COOLING

Indoor	Outdoor	Power supply	Voltage range	Compressor					OFM		IFM			
				MCA	TOCA	MFA	MSC	RLA	kW	FLA	kW	FLA		
FCAHG100HVEB	RZAG71N2V1B	50Hz ~ 220-240V	Minimum: -198 V- Maximum -264 V-	18.3	-	20	-	15.5	0.234	0.8	0.221	1.3		
FCAG35BVEB	x3 RZAG71N2V1B			17.9	-	20	-	15.5	0.234	0.8	0.044 x3	0.3 x3		
FCAG50BVEB	x2 RZAG71N2V1B			17.6	-	20	-	15.5	0.234	0.8	0.039 x2	0.3 x2		
FCAG100BVEB	RZAG71N2V1B			17.7	-	20	-	15.5	0.234	0.8	0.117	0.7		
FFA35A2VEB	x3 RZAG71N2V1B			17.6	-	20	-	15.5	0.234	0.8	0.050 x3	0.2 x3		
FFA50A2VEB	x2 RZAG71N2V1B			17.8	-	20	-	15.5	0.234	0.8	0.050 x2	0.4 x2		
FBA35A2VEB	x3 RZAG71N2V1B			21.3	-	20	-	15.5	0.234	0.8	0.089 x3	1.4 x3		
FBA50A2VEB	x2 RZAG71N2V1B			19.9	-	20	-	15.5	0.234	0.8	0.089 x2	1.4 x2		
FBA100A2VEB	RZAG71N2V1B			20.6	-	20	-	15.5	0.234	0.8	0.127	3.5		
FUA100AVEB9	RZAG71N2V1B			18.3	-	20	-	15.5	0.234	0.8	0.106	1.3		
FAA100BUV1B	RZAG71N2V1B			17.9	-	20	-	15.5	0.234	0.8	0.064	0.9		
FVA100AMVEB	RZAG71N2V1B			18.5	-	20	-	15.5	0.234	0.8	0.238	1.5		
FDXM35F3V1B	x3 RZAG71N2V1B			17.9	-	20	-	15.5	0.234	0.8	0.034 x3	0.3 x3		
FDXM50F3V1B	x2 RZAG71N2V1B			18.8	-	20	-	15.5	0.234	0.8	0.060 x2	0.9 x2		
FHA35AVEB98	x3 RZAG71N2V1B			18.8	-	20	-	15.5	0.234	0.8	0.090 x3	0.6 x3		
FHA50AVEB98	x2 RZAG71N2V1B			18.2	-	20	-	15.5	0.234	0.8	0.090 x2	0.6 x2		
FHA100AVEB98	RZAG71N2V1B			18.3	-	20	-	15.5	0.234	0.8	0.172	1.3		
FCAHG71HVEB	x2 RZAG100N2V1B			50Hz ~ 220-240V	Minimum: -198 V- Maximum -264 V-	22.3	-	32	-	18.8	0.234	1.2	0.091 x2	0.7 x2
FCAHG140HVEB	RZAG100N2V1B					22.3	-	32	-	18.8	0.234	1.2	0.244	1.4
FCAG35BVEB	x4 RZAG100N2V1B					22.0	-	32	-	18.8	0.234	1.2	0.044 x4	0.3 x4
FCAG50BVEB	x3 RZAG100N2V1B	21.7	-			32	-	18.8	0.234	1.2	0.039 x3	0.3 x3		
FCAG71BVEB	x2 RZAG100N2V1B	21.6	-			32	-	18.8	0.234	1.2	0.054 x2	0.4 x2		
FCAG140BVEB	RZAG100N2V1B	22.2	-			32	-	18.8	0.234	1.2	0.168	1.3		
FFA35A2VEB	x4 RZAG100N2V1B	21.6	-			32	-	18.8	0.234	1.2	0.050 x4	0.8		
FFA50A2VEB	x3 RZAG100N2V1B	22.0	-			32	-	18.8	0.234	1.2	0.050 x3	0.4 x3		
FBA35A2VEB	x4 RZAG100N2V1B	26.6	-			32	-	18.8	0.234	1.2	0.089 x4	1.4 x4		
FBA50A2VEB	x3 RZAG100N2V1B	25.2	-			32	-	18.8	0.234	1.2	0.089 x3	1.4 x3		
FBA71A2VEB	x2 RZAG100N2V1B	23.5	-			32	-	18.8	0.234	1.2	0.07 x2	1.3 x2		
FBA140A2VEB	RZAG100N2V1B	24.9	-			32	-	18.8	0.234	1.2	0.187	3.9		
FUA71AVEB9	x2 RZAG100N2V1B	22.7	-			32	-	18.8	0.234	1.2	0.046 x2	0.9 x2		
FAA71BUV1B	x2 RZAG100N2V1B	21.8	-			32	-	18.8	0.234	1.2	0.048 x2	0.5 x2		
FVA140AMVEB	RZAG100N2V1B	22.7	-			32	-	18.8	0.234	1.2	0.276	1.8		
FDXM35F3V1B	x4 RZAG100N2V1B	22.0	-			32	-	18.8	0.234	1.2	0.034 x4	0.3 x4		
FDXM50F3V1B	x3 RZAG100N2V1B	23.6	-			32	-	18.8	0.234	1.2	0.060 x3	0.9 x3		
FHA35AVEB98	x4 RZAG100N2V1B	23.3	-			32	-	18.8	0.234	1.2	0.090 x4	0.6 x4		
FHA50AVEB98	x3 RZAG100N2V1B	22.7	-			32	-	18.8	0.234	1.2	0.090 x3	0.6 x3		
FHA71AVEB98	x2 RZAG100N2V1B	22.5	-			32	-	18.8	0.234	1.2	0.110 x2	0.8 x2		
FHA140AVEB8	RZAG100N2V1B	22.7	-	32	-	18.8	0.234	1.2	0.251	1.8				

3D120944F

RZAG125-140NY1 INFRASTRUCTURE COOLING

Indoor	Outdoor	Power supply	Voltage range	MCA	TOCA	MFA	Compressor		OFM		IFM			
							MSC	RLA	kW	FLA	kW	FLA		
FCAHG71HVEB	x2 RZAG125N2Y1B	3N~ 50Hz 380-415V	Minimum: -342 V- Maximum -457 V-	15.0	-	16	-	11.8	0.234	1.2	0.091 x2	0.7 x2		
FCAHG140HVEB	RZAG125N2Y1B			15.0	-	16	-	11.8	0.234	1.2	0.244	1.4		
FCAG35BVEB	x4 RZAG125N2Y1B			12.2	-	16	-	9.3	0.234	1.2	0.044 x4	0.3 x4		
FCAG50BVEB	x3 RZAG125N2Y1B			12.9	-	16	-	10.3	0.234	1.2	0.039 x3	0.3 x3		
FCAG71BVEB	x2 RZAG125N2Y1B			14.4	-	16	-	11.8	0.234	1.2	0.054 x2	0.4 x2		
FCAG140BVEB	RZAG125N2Y1B			14.9	-	16	-	11.8	0.234	1.2	0.168	1.3		
FFA35A2VEB	x4 RZAG125N2Y1B			11.8	-	16	-	9.3	0.234	1.2	0.050 x4	0.2 x4		
FFA50A2VEB	x3 RZAG125N2Y1B			13.2	-	16	-	10.3	0.234	1.2	0.050 x3	0.4 x3		
FBA35A2VEB	x4 RZAG125N2Y1B			16.5	-	20	-	9.3	0.234	1.2	0.089 x4	1.4 x4		
FBA50A2VEB	x3 RZAG125N2Y1B			16.2	-	20	-	10.3	0.234	1.2	0.089 x3	1.4 x3		
FBA71A2VEB	x2 RZAG125N2Y1B			16.1	-	20	-	11.8	0.234	1.2	0.070 x2	1.3 x2		
FBA140A2VEB	RZAG125N2Y1B			17.4	-	20	-	11.8	0.234	1.2	0.187	3.9		
FUA71AVEB9	x2 RZAG125N2Y1B			15.4	-	16	-	11.8	0.234	1.2	0.046 x2	0.9 x2		
FAA71BUV1B	x2 RZAG125N2Y1B			14.6	-	16	-	11.8	0.234	1.2	0.048 x2	0.5 x2		
FVA140AMVEB9	RZAG125N2Y1B			15.4	-	16	-	11.8	0.234	1.2	0.276	1.8		
FDXM35F3V1B	x4 RZAG125N2Y1B			12.2	-	16	-	9.3	0.234	1.2	0.034 x4	0.3 x4		
FDXM50F3V1B	x3 RZAG125N2Y1B			14.8	-	16	-	10.3	0.234	1.2	0.060 x3	0.9 x3		
FHA35AVEB98	x4 RZAG125N2Y1B			13.4	-	16	-	9.3	0.234	1.2	0.090 x4	0.6 x4		
FHA50AVEB98	x3 RZAG125N2Y1B			13.8	-	16	-	10.3	0.234	1.2	0.090 x3	0.6 x3		
FHA71AVEB98	x2 RZAG125N2Y1B			15.2	-	16	-	11.8	0.234	1.2	0.110 x2	0.8 x2		
FHA140AVEB8	RZAG125N2Y1B			15.4	-	16	-	11.8	0.234	1.2	0.251	1.8		
FCAHG71HVEB	x2 RZAG140N2Y1B			3N~ 50Hz 380-415V	Minimum: -342 V- Maximum -457 V-	15.0	-	16	-	11.6	0.234	1.4	0.091 x2	0.7 x2
FCAHG140HVEB	RZAG140N2Y1B					15.0	-	16	-	11.6	0.234	1.4	0.244	1.4
FCAG35BVEB	x4 RZAG140N2Y1B					12.2	-	16	-	9.1	0.234	1.4	0.044 x4	0.3 x4
FCAG50BVEB	x3 RZAG140N2Y1B					12.9	-	16	-	10.1	0.234	1.4	0.039 x3	0.3 x3
FCAG71BVEB	x2 RZAG140N2Y1B					14.4	-	16	-	11.6	0.234	1.4	0.054 x2	0.4 x2
FCAG140BVEB	RZAG140N2Y1B					14.9	-	16	-	11.6	0.234	1.4	0.168	1.3
FFA35A2VEB	x4 RZAG140N2Y1B					11.8	-	16	-	9.1	0.234	1.4	0.050 x4	0.2 x4
FFA50A2VEB	x3 RZAG140N2Y1B	13.2	-			16	-	10.1	0.234	1.4	0.050 x3	0.4 x3		
FBA35A2VEB	x4 RZAG140N2Y1B	16.5	-			20	-	9.1	0.234	1.4	0.089 x4	1.4 x4		
FBA50A2VEB	x3 RZAG140N2Y1B	16.2	-			20	-	10.1	0.234	1.4	0.089 x3	1.4 x3		
FBA71A2VEB	x2 RZAG140N2Y1B	16.1	-			20	-	11.6	0.234	1.4	0.070 x2	1.3 x2		
FBA140A2VEB	RZAG140N2Y1B	17.4	-			20	-	11.6	0.234	1.4	0.187	3.9		
FUA71AVEB9	x2 RZAG140N2Y1B	15.4	-			16	-	11.6	0.234	1.4	0.046 x2	0.9 x2		
FAA71BUV1B	x2 RZAG140N2Y1B	14.6	-			16	-	11.6	0.234	1.4	0.048 x2	0.5 x2		
FVA140AMVEB	RZAG140N2Y1B	15.4	-			16	-	11.6	0.234	1.4	0.276	1.8		
FDXM35F3V1B	x4 RZAG140N2Y1B	12.2	-			16	-	9.1	0.234	1.4	0.034 x4	0.3 x4		
FDXM50F3V1B	x3 RZAG140N2Y1B	14.8	-			16	-	10.1	0.234	1.4	0.060 x3	0.9 x3		
FHA35AVEB98	x4 RZAG140N2Y1B	13.4	-			16	-	9.1	0.234	1.4	0.090 x4	0.6 x4		
FHA50AVEB98	x3 RZAG140N2Y1B	13.8	-			16	-	10.1	0.234	1.4	0.090 x3	0.6 x3		
FHA71AVEB98	x2 RZAG140N2Y1B	15.2	-			16	-	11.6	0.234	1.4	0.110 x2	0.8 x2		
FHA140AVEB8	RZAG140N2Y1B	15.4	-			16	-	11.6	0.234	1.4	0.251	1.8		

3D120944F

RZAG-NV1/NY1

Symbols	Notes
MCA Minimum Circuit Ampere [A]	1 The -RLA- is based on the following conditions. Cooling Indoor temperature -27.0°C DB / -19.0°C WB Outdoor temperature -35.0°C DB Heating Indoor temperature -20.0°C DB Outdoor temperature -7.0°C DB / -6.0°C WB
TOCA Total overcurrent amps [A]	
MFA Maximum Fuse Ampere [A]	
MSC Maximum current of the starting compressor [A]	
RLA Rated load amps [A]	
OFM Outdoor fan motor	
IFM Indoor fan motor	
FLA Full Load Ampere [A]	2 -TOCA- is the total value of each overcurrent set.
kW Fan motor rated output [kW]	3 Voltage range The units are suitable for use with electrical systems in which the voltage supplied to the unit terminals is not below or above the listed range limits. 4 The maximum allowable voltage that is unbalanced between phases is -2%. 5 -MCA- is the maximum input current. The capacity of the -MFA- must be greater than that of the -MCA-. Select the -MFA- according to the table. 6 Select the wire size according to the MCA. 7 -MFA- is used to select the circuit breaker and the ground fault circuit interruptor. Earth leakage circuit breaker

3D120944F



RZAG-NV1 / RZAG-NY1

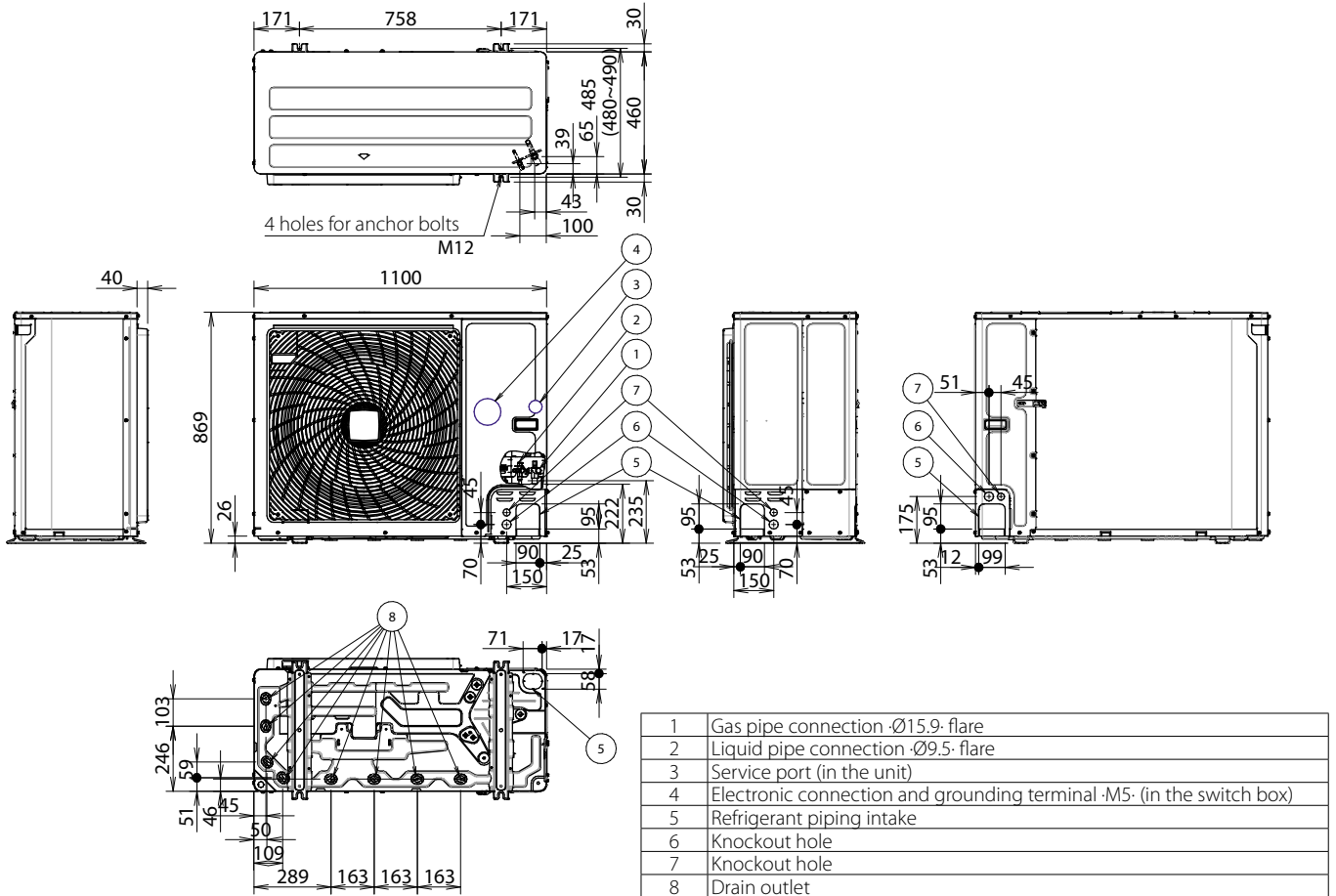

3D120936

**RZAG-NV1/NY1
RZA-D**

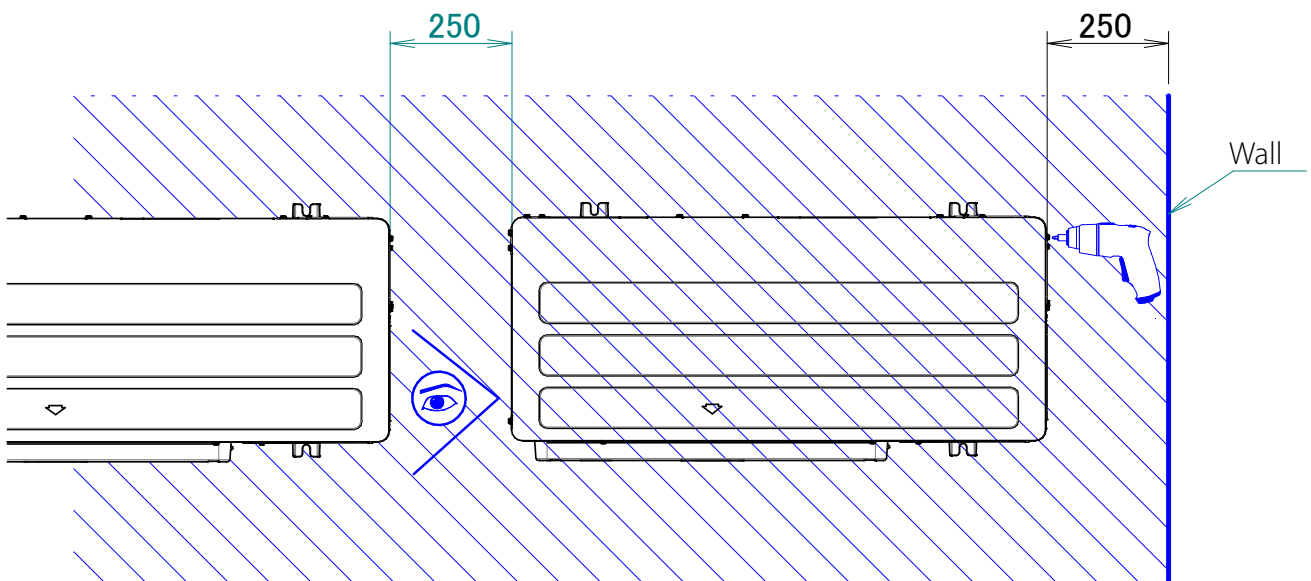

* For optimal serviceability, provide ·250·mm of free space.
For more installation and service space guidelines, see drawing ·3D069554·.

3D120935

**RZAG-NV1/NY1
RZA-D**

Suction side	In the illustrations below, the service space at the suction side is based on 35°C DB and cooling operation. Foresee more space in the following cases: <ul style="list-style-type: none"> • When the suction side temperature regularly exceeds this temperature. • When the heat load of the outdoor units is expected to regularly exceed the maximum operating capacity.
Discharge side	Take refrigerant piping work into account when positioning the units. If your layout does not match with any of the layouts below, contact your dealer.

Single unit | Single row of units

	A~E	H_B, H_D, H_U	(mm)									
			a	b	c	d	e	e_B		e_D		
	B	—		≥100								
	A, B, C	—	≥100 ⁽¹⁾	≥100	≥100							
	B, E	—		≥100			≥1,000		≤500			
	A, B, C, E	—	≥150 ⁽¹⁾	≥150	≥150		≥1,000		≤500			
	D	—				≥500						
	D, E	—				≥500	≥1,000	≥500				
	B, D	$H_D > H_U$ $H_D \leq H_U$		≥100		≥500						
	B, D, E	$H_D > H_U$	$H_B \leq \frac{1}{2}H_U$	≥250		≥750	≥1,000	≤500			1	
			$\frac{1}{2}H_U < H_B \leq H_U$	≥250		≥1,000	≥1,000	≤500				
		$H_D \leq H_U$	$H_B \leq \frac{1}{2}H_U$		≥100		≥1,000	≥1,000		≤500		
$\frac{1}{2}H_U < H_B \leq H_U$				≥200		≥1,000	≥1,000		≤500			
	A, B, C	—	≥200 ⁽¹⁾	≥300	≥1,000							
	A, B, C, E	—	≥200 ⁽¹⁾	≥300	≥1,000		≥1,000		≤500			
	D	—				≥1,000						
	D, E	—				≥1,000	≥1,000	≤500				
	B, D	$H_D > H_U$ $H_D \leq H_U$	$H_B \leq \frac{1}{2}H_U$		≥300		≥1,000					
			$\frac{1}{2}H_U < H_B \leq H_U$		≥250		≥1,500					
	B, D, E	$H_D > H_U$	$H_B \leq \frac{1}{2}H_U$	≥300		≥1,000	≥1,000	≤500			1+2	
			$\frac{1}{2}H_U < H_B \leq H_U$	≥300		≥1,250	≥1,000	≤500				
		$H_D \leq H_U$	$H_B \leq \frac{1}{2}H_U$		≥250		≥1,500	≥1,000		≤500		
			$\frac{1}{2}H_U < H_B \leq H_U$		≥300		≥1,500	≥1,000		≤500		
	$H_D > H_U$											

(1) For better serviceability, use a distance ≥250 mm

A,B,C,D Obstacles (walls/baffle plates)

E Obstacle (roof)

a,b,c,d,e Minimum service space between the unit and obstacles A, B, C, D and E

eB Maximum distance between the unit and the edge of obstacle E, in the direction of obstacle B

eD Maximum distance between the unit and the edge of obstacle E, in the direction of obstacle D

HU Height of the unit

HB,HD Height of obstacles B and D

1 Seal the bottom of the installation frame to prevent discharged air from flowing back to the suction side through the bottom of the unit.

2 Maximum two units can be installed.

Not allowed



RZAG-NV1/NY1 RZA-D

Multiple rows of units

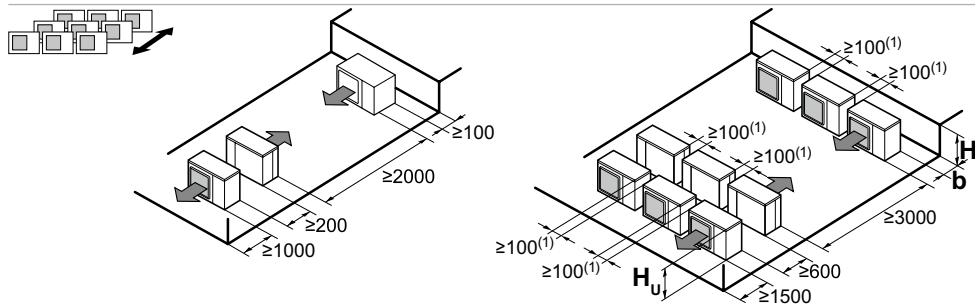

H_b, H_u	b (mm)
$H_b \leq \frac{1}{2}H_u$	$b \geq 250$
$\frac{1}{2}H_u < H_b \leq H_u$	$b \geq 300$
$H_b > H_u$	⊘

(1) For better serviceability, use a distance ≥ 250 mm

Stacked units (max. 2 levels)



A1

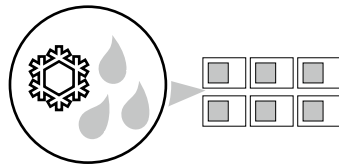

A2

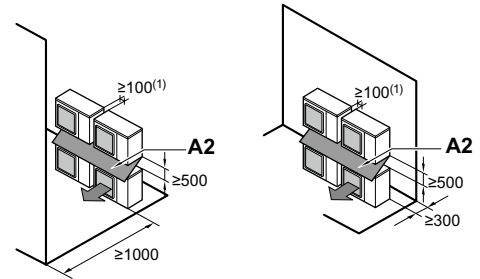

B1

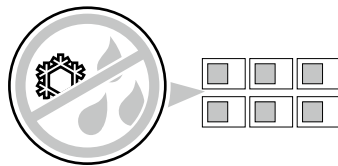

B2

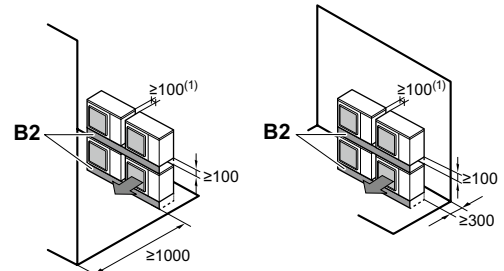

(1) For better serviceability, use a distance ≥ 250 mm

A1=>A2 (A1) If there is danger of drainage dripping and freezing between the upper and lower units...

(A2) Then install a roof between the upper and lower units. Install the upper unit high enough above the lower unit to prevent ice buildup at the upper unit's bottom plate.

B1=>B2 (B1) If there is no danger of drainage dripping and freezing between the upper and lower units...

(B2) Then it is not required to install a roof, but seal the gap between the upper and lower units to prevent discharged air from flowing back to the suction side through the bottom of the unit.

RZAG-NV1/NY1

To determine if adding additional refrigerant is necessary

If	Then
$(L1+L2+L3+L4+L5+L6+L7) \leq$ chargeless length Chargeless length= • 10 m (size-down) • 40 m (standard) • 15 m (size-up)	You do not have to add additional refrigerant.
$(L1+L2+L3+L4+L5+L6+L7) >$ chargeless length	You must add additional refrigerant. For future servicing, encircle the selected amount in the tables below.

INFORMATION

Piping length is the largest one way length of liquid piping.

To determine the additional refrigerant amount (R in kg) (in case of pair)

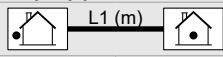
Standard liquid pipe size						
						
L1:	40~50	50~55	55~60	60~70	70~80	80~85
R:	0.35	0.7 ^(a) 0.55 ^(b)	0.7 ^(a)	1.05 ^(a)	1.4 ^(a)	1.55 ^(a)

(a) Only for RZAG100~140.

(b) Only for RZAG71.

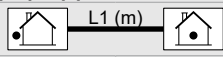
Size-up liquid pipe size				
				
L1:	15~20	20~25	25~30	30~35
R:	0.35	0.7	1.05 ^(a)	1.4 ^(a)

(a) Only for RZAG100~140.

To determine the additional refrigerant amount (R in kg) (in case of twin, triple and double twin)

1. Determine G1 and G2.

G1 (m)	Total length of <x> liquid piping x= $\varnothing 9.5$ mm (standard) x= $\varnothing 12.7$ mm (size-up)
G2 (m)	Total length of $\varnothing 6.4$ mm liquid piping

2. Determine R1 and R2.

If	Then
$G1 > 40$ m ^(a)	Use the table below to determine R1 (length= $G1-40$ m) ^(a) and R2 (length= $G2$). R1=0.0 kg.
$G1 \leq 40$ m ^(a) (and $G1+G2 > 40$ m) ^(a)	Use the table below to determine R2 (length= $G1+G2-40$ m) ^(a)

(a) In case of size-up: Replace 40 m by 15 m.

Standard liquid pipe size						
Length (m)						
	0~10	10~15	15~20	20~30	30~40	40~45
R1:	0.35	0.7 ^(a) 0.55 ^(b)	0.7 ^(a)	1.05 ^(a)	1.4 ^(a)	1.55 ^(a)
R2:	0.2	0.4	0.4	0.6	0.8 ^(a)	1.0 ^(a)

(a) Only for RZAG100~140.

(b) Only for RZAG71.

Size-up liquid pipe size						
Length (m)						
	0~5	5~10	10~15	15~20	20~30	30~40
R1:	0.35	0.7	1.05 ^(a)	1.4 ^(a)	-	-
R2:	0.35	0.35	0.7 ^(a)	1.05 ^(a)	1.05 ^(a)	1.4 ^(a)

(a) Only for RZAG100~140.

3. Determine the additional refrigerant amount: R=R1+R2.

Examples

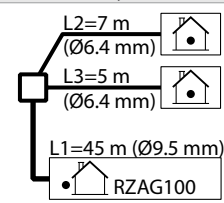
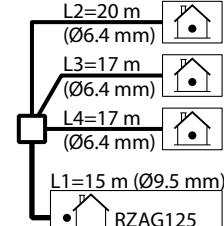
Layout	Additional refrigerant amount (R)
	Case: Twin, standard liquid pipe size 1. G1 Total $\varnothing 9.5 \Rightarrow G1=45$ m G2 Total $\varnothing 6.4 \Rightarrow G2=7+5=12$ m Case: $G1 > 40$ m 2. R1 Length= $G1-40$ m=5 m $\Rightarrow R1=0.35$ kg R2 Length= $G2=12$ m $\Rightarrow R2=0.4$ kg 3. R $R=R1+R2=0.35+0.4=0.75$ kg
	Case: Triple, standard liquid pipe size 1. G1 Total $\varnothing 9.5 \Rightarrow G1=15$ m G2 Total $\varnothing 6.4 \Rightarrow G2=20+17+17=54$ m Case: $G1 \leq 40$ m (and $G1+G2 > 40$ m) 2. R1 $R1=0.0$ kg R2 Length= $G1+G2-40$ m= $15+54-40=29$ m $\Rightarrow R2=0.6$ kg 3. R $R=R1+R2=0.0+0.6=0.6$ kg

RZASG100MY1

Indoor	Outdoor	Power supply	Voltage range		MCA	TOCA	MFA	Compressor		OFM		IFM	
								MSC	RLA	kW	FLA	kW	FLA
FCAG35BVEB	x3 RZASG100M7Y1B	3N~ 50Hz 380-415V	Minimum: -342 V-	Maximum -456 V-	13.0	-	16	-	10.6	0.2	1	0.044 x3	0.3 x3
FCAG50BVEB	x2 RZASG100M7Y1B				12.7	-	16	-	10.6	0.2	1	0.039 x2	0.3 x2
FCAG100BVEB	RZASG100M7Y1B				14.2	-	16	-	12	0.2	1	0.117	0.7
FFA35A2VEB	x3 RZASG100M7Y1B				13.3	-	16	-	10.6	0.2	1	0.050 x3	0.4 x3
FFA50A2VEB	x2 RZASG100M7Y1B				12.9	-	16	-	10.6	0.2	1	0.050 x2	0.4 x2
FBA35A2VEB	x3 RZASG100M7Y1B				13.9	-	16	-	10.6	0.2	1	0.089 x3	0.6 x3
FBA50A2VEB	x2 RZASG100M7Y1B				13.3	-	16	-	10.6	0.2	1	0.089 x2	0.6 x2
FBA100A2VEB	RZASG100M7Y1B				14.6	-	16	-	12	0.2	1	0.127	1
FNA35A2VEB	x3 RZASG100M7Y1B				13.0	-	16	-	10.6	0.2	1	0.034 x3	0.3 x3
FNA50A2VEB	x2 RZASG100M7Y1B				13.1	-	16	-	10.6	0.2	1	0.060 x2	0.5 x2
FUA100AVEB9	RZASG100M7Y1B				14.9	-	16	-	12	0.2	1	0.106	1.3
FAA100BUV1B	RZASG100M7Y1B				14.4	-	16	-	12	0.2	1	0.064	0.9
FVA100AMVEB	RZASG100M7Y1B				14.8	-	16	-	12	0.2	1	0.238	1.2
FDXM35F3V1B	x3 RZASG100M7Y1B				13.0	-	16	-	10.6	0.2	1	0.034 x3	0.3 x3
FDXM50F3V1B	x2 RZASG100M7Y1B				13.1	-	16	-	10.6	0.2	1	0.060 x2	0.5 x2
FHA35AVEB98	x3 RZASG100M7Y1B				13.9	-	16	-	10.6	0.2	1	0.090 x3	0.6 x3
FHA50AVEB98	x2 RZASG100M7Y1B				13.3	-	16	-	10.6	0.2	1	0.090 x2	0.6 x2
FHA100AVEB8	RZASG100M7Y1B				14.9	-	16	-	12	0.2	1	0.172	1.3

3D110014H

RZASG125-140MY1

Indoor	Outdoor	Power supply	Voltage range		MCA	TOCA	MFA	Compressor		OFM		IFM				
								MSC	RLA	kW	FLA	kW	FLA			
FCAG35BVEB	x4 RZASG125M7Y1B	3N~ 50Hz 380-415V	Minimum: -342 V-	Maximum -456 V-	12.2	-	16	-	9.5	0.2	1	0.044 x4	0.3 x4			
FCAG50BVEB	x3 RZASG125M7Y1B				13.0	-	16	-	10.6	0.2	1	0.039 x3	0.3 x3			
FCAG60BVEB	x2 RZASG125M7Y1B				12.7	-	16	-	10.6	0.2	1	0.044 x2	0.3 x2			
FCAG125BVEB	RZASG125M7Y1B				14.6	-	16	-	12	0.2	1	0.168	1			
FFA35A2VEB	x4 RZASG125M7Y1B				12.6	-	16	-	9.5	0.2	1	0.050 x4	0.4 x4			
FFA50A2VEB	x3 RZASG125M7Y1B				13.3	-	16	-	10.6	0.2	1	0.050 x3	0.4 x3			
FFA60A2VEB	x2 RZASG125M7Y1B				13.3	-	16	-	10.6	0.2	1	0.050 x2	0.6 x2			
FBA35A2VEB	x4 RZASG125M7Y1B				13.4	-	16	-	9.5	0.2	1	0.089 x4	0.6 x4			
FBA50A2VEB	x3 RZASG125M7Y1B				13.9	-	16	-	10.6	0.2	1	0.089 x3	0.6 x3			
FBA60A2VEB	x2 RZASG125M7Y1B				13.1	-	16	-	10.6	0.2	1	0.070 x2	0.5 x2			
FBA125A2VEB	RZASG125M7Y1B				15.1	-	16	-	12	0.2	1	0.187	1.5			
FNA35A2VEB	x4 RZASG125M7Y1B				12.2	-	16	-	9.5	0.2	1	0.034 x4	0.3 x4			
FNA50A2VEB	x3 RZASG125M7Y1B				13.6	-	16	-	10.6	0.2	1	0.060 x3	0.5 x3			
FNA60A2VEB	x2 RZASG125M7Y1B				13.1	-	16	-	10.6	0.2	1	0.060 x2	0.5 x2			
FUA125AVEB9	RZASG125M7Y1B				15.0	-	16	-	12	0.2	1	0.106	1.4			
FDA125AVEB8	RZASG125M7Y1B				15.7	-	16	-	12	0.2	1	0.35	2.1			
FVA125AMVEB	RZASG125M7Y1B				14.8	-	16	-	12	0.2	1	0.238	1.2			
FDXM35F3V1B	x4 RZASG125M7Y1B				12.2	-	16	-	9.5	0.2	1	0.034 x4	0.3 x4			
FDXM50F3V1B	x3 RZASG125M7Y1B				13.6	-	16	-	10.6	0.2	1	0.060 x3	0.5 x3			
FDXM60F3V1B	x2 RZASG125M7Y1B				13.1	-	16	-	10.6	0.2	1	0.060 x2	0.5 x2			
FHA35AVEB98	x4 RZASG125M7Y1B				13.4	-	16	-	9.5	0.2	1	0.090 x4	0.6 x4			
FHA50AVEB98	x3 RZASG125M7Y1B				13.9	-	16	-	10.6	0.2	1	0.090 x3	0.6 x3			
FHA60AVEB98	x2 RZASG125M7Y1B				13.3	-	16	-	10.6	0.2	1	0.091 x2	0.6 x2			
FHA125AVEB8	RZASG125M7Y1B				15.1	-	16	-	12	0.2	1	0.217	1.5			
FCAG35BVEB	x4 RZASG140M7Y1B				3N~ 50Hz 380-415V	Minimum: -342 V-	Maximum -456 V-	12.2	-	16	-	9.5	0.2	1	0.044 x4	0.3 x4
FCAG50BVEB	x3 RZASG140M7Y1B							12.9	-	16	-	10.5	0.2	1	0.039 x3	0.3 x3
FCAG71BVEB	x2 RZASG140M7Y1B							14.4	-	16	-	12	0.2	1	0.054 x2	0.4 x2
FCAG140BVEB	RZASG140M7Y1B	14.6	-	16				-	12	0.2	1	0.168	1			
FFA35A2VEB	x4 RZASG140M7Y1B	12.6	-	16				-	9.5	0.2	1	0.050 x4	0.4 x4			
FFA50A2VEB	x3 RZASG140M7Y1B	13.2	-	16				-	10.5	0.2	1	0.050 x3	0.4 x3			
FBA35A2VEB	x4 RZASG140M7Y1B	13.4	-	16				-	9.5	0.2	1	0.089 x4	0.6 x4			
FBA50A2VEB	x3 RZASG140M7Y1B	13.8	-	16				-	10.5	0.2	1	0.089 x3	0.6 x3			
FBA71A2VEB	x2 RZASG140M7Y1B	14.6	-	16				-	12	0.2	1	0.070 x2	0.5 x2			
FBA140A2VEB	RZASG140M7Y1B	15.1	-	16				-	12	0.2	1	0.187	1.5			
FNA35A2VEB	x4 RZASG140M7Y1B	12.2	-	16				-	9.5	0.2	1	0.034 x4	0.3 x4			
FNA50A2VEB	x3 RZASG140M7Y1B	13.5	-	16				-	10.5	0.2	1	0.060 x3	0.5 x3			
FUA71AVEB9	x2 RZASG140M7Y1B	15.4	-	16				-	12	0.2	1	0.046 x2	0.9 x2			
FAA71BUV1B	x2 RZASG140M7Y1B	14.4	-	16				-	12	0.2	1	0.048 x2	0.4 x2			
FVA71AMVEB	x2 RZASG140M7Y1B	14.8	-	16				-	12	0.2	1	0.117 x2	0.6 x2			
FVA140AMVEB	RZASG140M7Y1B	15.0	-	16				-	12	0.2	1	0.276	1.4			
FDXM35F3V1B	x4 RZASG140M7Y1B	12.2	-	16				-	9.5	0.2	1	0.034 x4	0.3 x4			
FDXM50F3V1B	x3 RZASG140M7Y1B	13.5	-	16				-	10.5	0.2	1	0.060 x3	0.5 x3			
FHA35AVEB98	x4 RZASG140M7Y1B	13.4	-	16				-	9.5	0.2	1	0.090 x4	0.6 x4			
FHA50AVEB98	x3 RZASG140M7Y1B	13.8	-	16				-	10.5	0.2	1	0.090 x3	0.6 x3			
FHA71AVEB98	x2 RZASG140M7Y1B	15.2	-	16				-	12	0.2	1	0.110 x2	0.8 x2			
FHA140AVEB8	RZASG140M7Y1B	15.4	-	16				-	12	0.2	1	0.251	1.8			

3D110014H



RZASG-MV1/MY1

Symbols			Notes
MCA	Minimum Circuit Ampere	[A]	1 The -RLA- is based on the following conditions. Cooling Indoor temperature -27.0°C DB / -19.0°C WB Outdoor temperature -35.0°C DB
TOCA	Total overcurrent amps	[A]	
MFA	Maximum Fuse Ampere	[A]	
MSC	Maximum current of the starting compressor	[A]	Heating Indoor temperature -20.0°C DB Outdoor temperature -7.0°C DB / -6.0°C WB
RLA	Rated load amps	[A]	
OFM	Outdoor fan motor		2 -TOCA- is the total value of each overcurrent set.
IFM	Indoor fan motor		
FLA	Full Load Ampere	[A]	3 Voltage range The units are suitable for use with electrical systems in which the voltage supplied to the unit terminals is not below or above the listed range limits.
kW	Fan motor rated output	[kW]	
			4 The maximum allowable voltage that is unbalanced between phases is -2%.
			5 -MCA- is the maximum input current. The capacity of the -MFA- must be greater than that of the -MCA-.
			Select the -MFA- according to the table.
			6 Select the wire size according to the MCA.
			7 -MFA- is used to select the circuit breaker and the ground fault circuit interruptor. Earth leakage circuit breaker

3D110014H

RZASG71MV1

4 holes for anchor bolts
M12

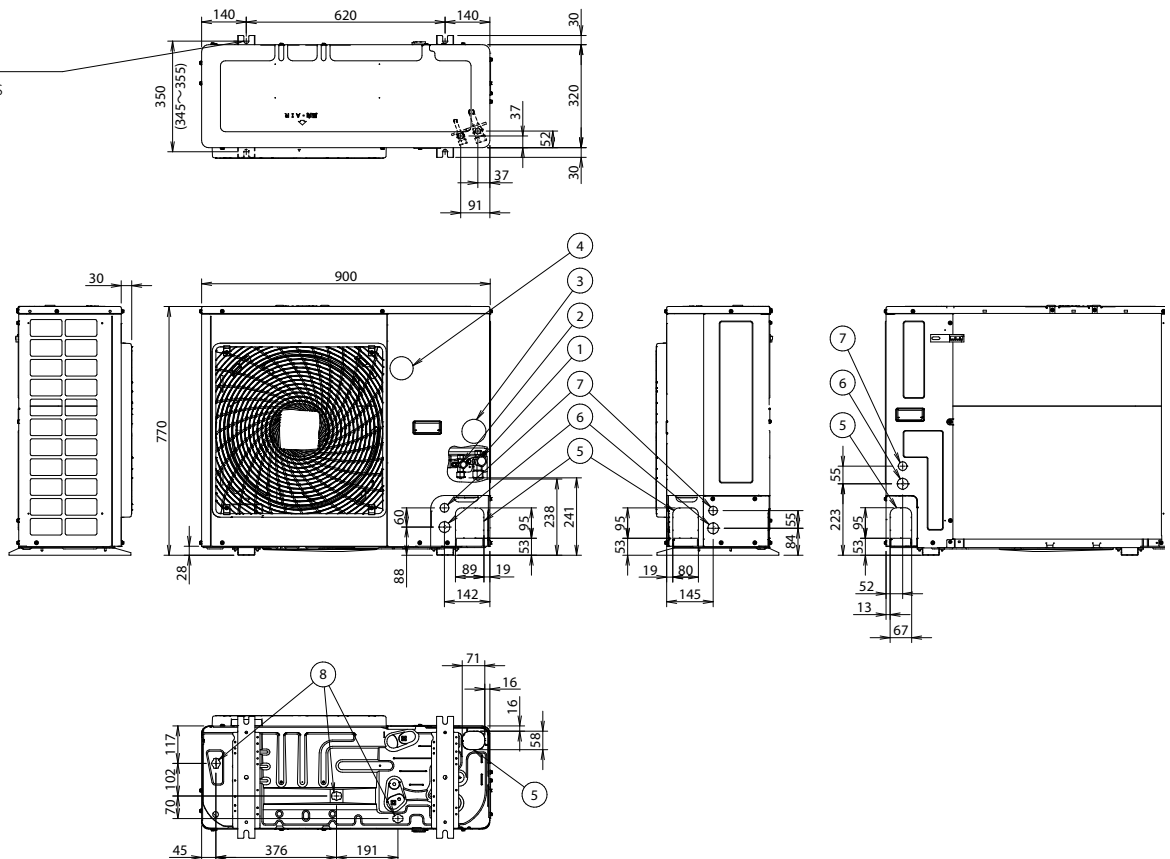

1	Gas pipe connection -Ø15.9- flare
2	Liquid pipe connection -Ø9.5- flare
3	Service port (in the unit)
4	Electronic connection and grounding terminal -M5- (in the switch box)
5	Refrigerant piping intake
6	Power supply wiring intake (knockout hole Ø34)
7	Control wiring intake (knockout hole Ø27)
8	Drain outlet

3D110013



DETAILED TECHNICAL DRAWINGS

RZASG100-140MV1/MY1

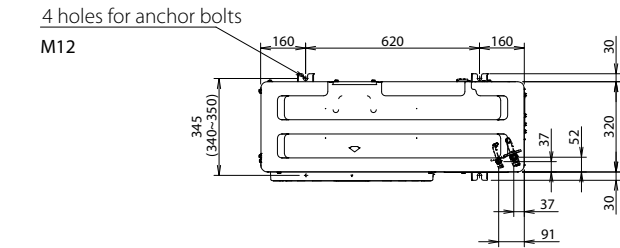

Model	AA	AB
RZAG71* / RZASG100-125* / AZAS100-125*	331	337
RZASG140* / AZAS140*	414	420

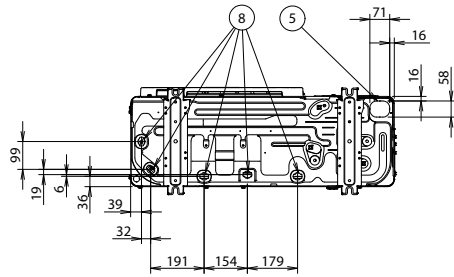
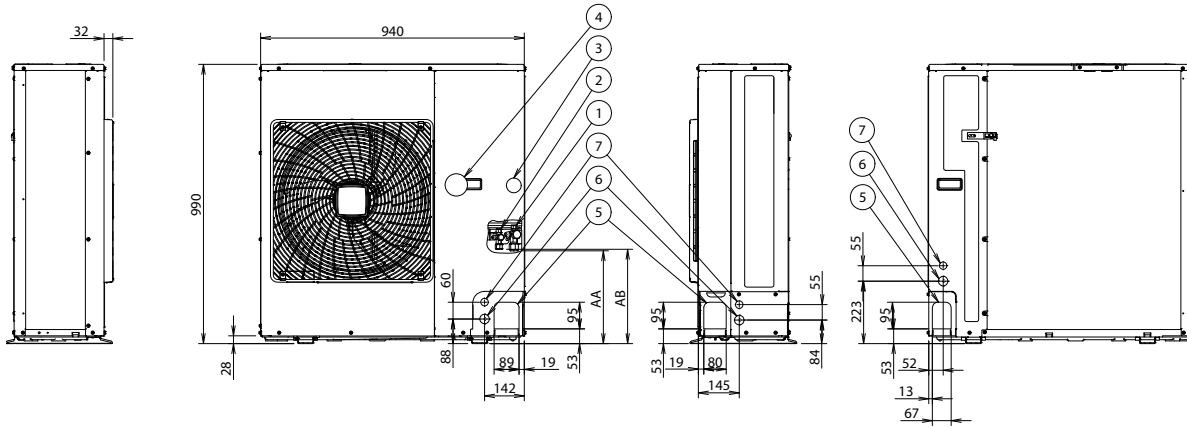

1	Gas pipe connection ·Ø15.9· flare
2	Liquid pipe connection ·Ø9.5· flare
3	Service port (in the unit)
4	Electronic connection and grounding terminal ·M5· (in the switch box)
5	Refrigerant piping intake
6	Power supply wiring intake (knockout hole Ø34)
7	Control wiring intake (knockout hole Ø27)
8	Drain outlet

3D110011



RZASG-MV1/MY1

Installation service space

The measure of these values is "mm".

(A) When there are obstacles on suction sides.

• **No obstacle above**

(1) Stand-alone installation

- Obstacle on the suction side only

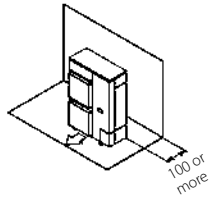

- Obstacle on both sides and suction side, too

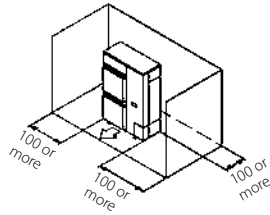

(2) Series installation (2 or more) (note 1)

- Obstacle on the suction side and both sides

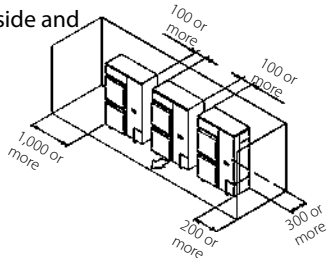

• **Obstacle above, too**

(1) Stand-alone installation

- Obstacle on the suction side, too

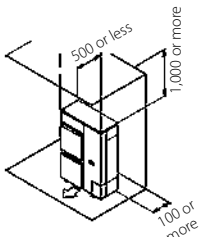

- Obstacle on both sides and suction side, too

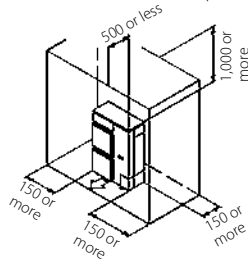

(2) Series installation (2 or more) (note 1)

- Obstacle on the suction side and both sides

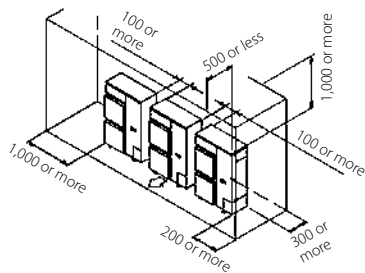

(B) When there are obstacles on discharge sides.

• **No obstacle above**

(1) Stand-alone installation

- Obstacle on the discharge side only

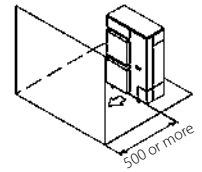

(2) Series installation (2 or more) (note 1)

- Obstacle on the suction side only

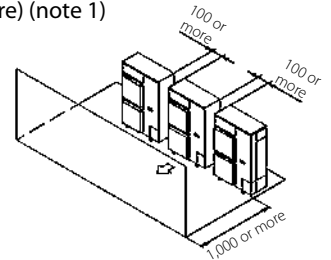

• **Obstacle above, too**

(1) Stand-alone installation

- Obstacle on the discharge side only, too

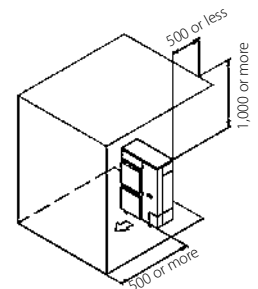

(2) Series installation (2 or more) (note 1)

- Obstacle on discharge side

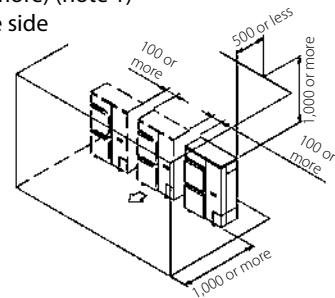

(C) When there are obstacles on both suction and discharge sides:

Pattern 1

When the obstacles on the discharge side is higher than the unit. (L > H)

(There is no limit for the height of obstructions on the suction side.)

• **No obstacle above**

(1) Stand-alone installation

- No obstacle above

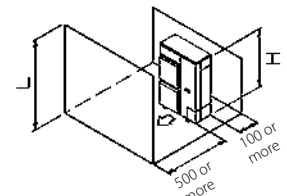

(2) Series installation (2 or more) (note 1)

- No obstacle above

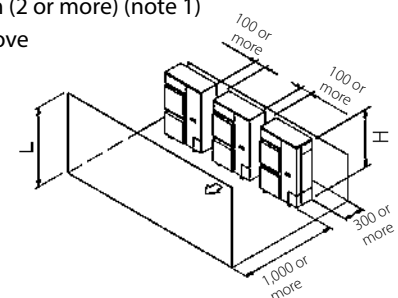

3D069554

RZASG-MV1/MY1

• Obstacle above, too

(1) Stand-alone installation (note 2)

- When there are obstacles on suction, discharge and top sides.

The relations between H, A and L are as follows:

	L	A
L ≤ H	L ≤ 1/2H	750 or more
	1/2H < L ≤ H	1,000 or more
H < L	Set the stand as: L ≤ H Refer to the column of L ≤ H for A	

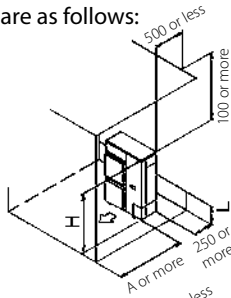

(2) Series installation (2 or more) (note 1,2)

- When there are obstacles on suction, discharge and top sides.
- The relations between H, A and L are as follows:

	L	A
L ≤ H	L ≤ 1/2H	1,000 or more
	1/2H < L ≤ H	1,250 or more
H < L	Set the stand as: L ≤ H Refer to the column of L ≤ H for A	

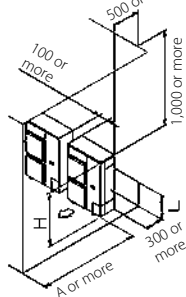

Limit of series installation is 2 units.

Pattern 2

When the obstacle on the discharge side is lower than the unit (L ≤ H)

(There is no limit for the height of obstructions on the suction side.)

• No obstacle above

(1) Stand-alone installation

- No obstacle above

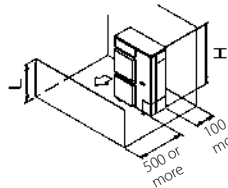

(2) Series installation (2 or more) (note 1, 2)

- When there are obstacles on both suction and discharge sides.

The relations between H, A and L are as follows.

	L	A
L ≤ H	L ≤ 1/2H	250 or more
	1/2H < L ≤ H	300 or more

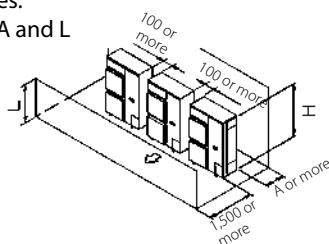

• Obstacle above

(1) Stand-alone installation (note 2)

- When there are obstacles on suction, discharge and top sides.

The relations between H, A and L are as follows.

	L	A
L ≤ H	L ≤ 1/2H	100 or more
	1/2H < L ≤ H	200 or more
H < L	Set the stand as: L ≤ H Refer to the column of L ≤ H for A	

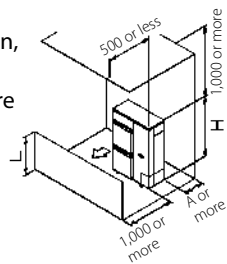

(2) Series installation (2 or more) (note 1,2)

- When there are obstacles on suction, discharge and top sides.
- The relations between H, A and L are as follows.

	L	A
L ≤ H	L ≤ 1/2H	250 or more
	1/2H < L ≤ H	300 or more
H < L	Set the stand as: L ≤ H Refer to the column of L ≤ H for A	

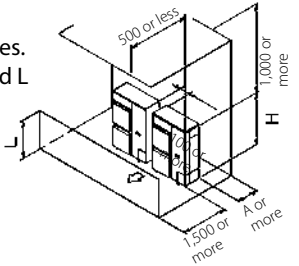

Limit of series installation is 2 units.

(D) Double-decker installation

(1) Obstacle on the discharge side. (1)

- Do not exceed two levels for stacked installation.
- Install a roof cover similar to A (field supply), as outdoor units with downward drainage are prone to dripping and freezing.
- Install the upper-level outdoor unit so that its bottom plate is a sufficient height above the roof cover. This is to prevent the buildup of ice on the underside of the bottom plate.

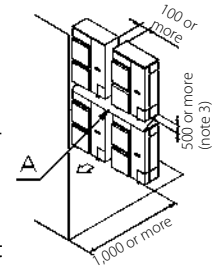

(2) Obstacle on the suction side. (1)

- Do not exceed two levels for stacked installation.
- Install a roof cover similar to A (field supply), as outdoor units with downward drainage are prone to dripping and freezing.
- Install the upper-level outdoor unit so that its bottom plate is a sufficient height above the roof cover. This is to prevent the buildup of ice on the underside of the bottom plate.

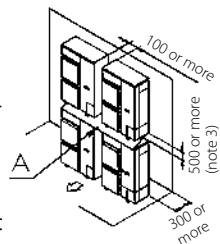

(E) Multiple rows of series installation (on the rooftop, etc.)

(1) One row of stand-alone installation

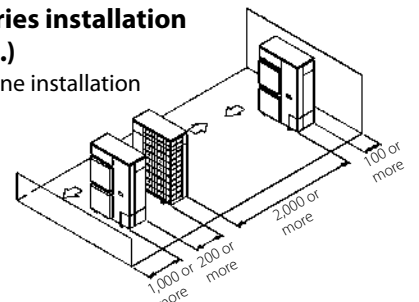

(2) Rows of series installation (2 or more)

The relations between H, A and L are as follows.

	L	A
L ≤ H	L ≤ 1/2H	1,000 or more
	1/2H < L ≤ H	1,250 or more
H < L	Set the stand as: L ≤ H Refer to the column of L ≤ H for A	

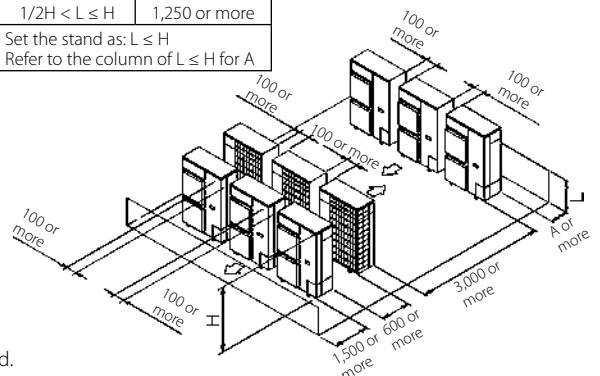

NOTES

1. In case of the sideways's piping, make a 100mm gap between the unit above.
2. Close the bottom of the installation frame to prevent the discharged air from being bypassed.
3. It is not necessary to install a roof cover if there is no danger of drainage dripping and freezing. In this case, the space between the upper and lower outdoor units should be at least 100mm. Close off the gap between the upper and lower units so there is no re intake of discharged air.



RZASG-MV1/MY1

To determine if adding additional refrigerant is necessary

if	Then
$(L1+L2+L3+L4+L5+L6+L7) \leq 30$ m (chargeless length)	You do not have to add additional refrigerant.
$(L1+L2+L3+L4+L5+L6+L7) > 30$ m (chargeless length)	You must add additional refrigerant. For future servicing, encircle the selected amount in the tables below.

INFORMATION

Piping length is the largest one way length of liquid piping.

To determine the additional refrigerant amount (R in kg) (in case of pair)

	L1 (m)	
	30~40 m	40~50 m
L1:		
R:	0.35 kg	0.7 kg

To determine the additional refrigerant amount (R in kg) (in case of twin, triple and double twin)

1. Determine R1 and R2.

if	Then
$G1 > 30$ m	Use the table below to determine R1
$G1 \leq 30$ m (and $G1+G2 > 30$ m)	$R1 = 0.0$ kg. Use the table below to determine R2.

	Length (total length of liquid piping – 30 m)				
	0~10 m	10~20 m	20~30 m	30~40 m	40~45 m
R1:	0.35 kg	0.7 kg	1.05 kg ^(a)	1.4 kg ^(a)	
R2:	0.2 kg	0.4 kg	0.6 kg	0.8 kg ^(a)	1 kg ^(b)

a) Only for RZASG100~140.

b) Only for RZASG100+125.

2. Determine the additional refrigerant amount: $R=R1+R2$.

Examples

Layout	Additional refrigerant amount (R)		
<p>RZASG100</p>	Case: Twin, standard liquid pipe size		
	1.	G1	Total Ø9.5 => $G1=35$ m
		G2	Total Ø6.4 => $G2=7+5=12$ m
	2.	Case: $G1 > 30$ m	
	R1	Length= $G1-30$ m= 5 m => $R1=0.35$ kg	
	R2	Length= $G2=12$ m => $R2=0.4$ kg	
3.	R	$R=R1+R2=0.35+0.4=0.75$ kg	
<p>RZASG125</p>	Case: Triple, standard liquid pipe size		
	1.	G1	Total Ø9.5 => $G1=5$ m
		G2	Total Ø6.4 => $G2=15+12+17=44$ m
	2.	Case: $G1 \leq 30$ m (and $G1+G2 > 30$ m)	
	R1	$R1=0.0$ kg	
	R2	Length= $G1+G2-30$ m = $5+44-30=19$ m => $R2=0.4$ kg	
3.	R	$R=R1+R2=0.0+0.4=0.4$ kg	

4PEN485928-1D_2019_04

DETAILED TECHNICAL DRAWINGS

RZASG71-100MV

Indoor	Outdoor	Power supply	Voltage range	MCA	TOCA	MFA	Compressor		OFM		IFM	
							MSC	RLA	kW	FLA	kW	FLA
FCAG35BVEB	x3 RZASG100MUV	50Hz ~ 220-240V	Minimum: -198 V- Maximum -264 V-	21.7	-	25	-	19	0.2	1	0.044 x3	0.3 x3
FCAG50BVEB	x2 RZASG100MUV			21.4	-	25	-	19	0.2	1	0.039 x2	0.3 x2
FCAG100BVEB	RZASG100MUV			21.5	-	25	-	19	0.2	1	0.117	0.7
FFA35A2VEB9	x3 RZASG100MUV			22.0	-	25	-	19	0.2	1	0.050 x3	0.4 x3
FFA50A2VEB9	x2 RZASG100MUV			21.6	-	25	-	19	0.2	1	0.050 x2	0.4 x2
FBA35A2VEB9	x3 RZASG100MUV			22.7	-	25	-	19	0.2	1	0.089 x3	0.6 x3
FBA50A2VEB9	x2 RZASG100MUV			22.0	-	25	-	19	0.2	1	0.089 x2	0.6 x2
FBA100A2VEB9	RZASG100MUV			21.8	-	25	-	19	0.2	1	0.127	1
FNA35A2VEB9	x3 RZASG100MUV			21.7	-	25	-	19	0.2	1	0.034 x3	0.3 x3
FNA50A2VEB9	x2 RZASG100MUV			21.8	-	25	-	19	0.2	1	0.060 x2	0.5 x2
FUA100AVEB9	RZASG100MUV			22.2	-	25	-	19	0.2	1	0.106	1.3
FAA100BUV1B	RZASG100MUV			21.7	-	25	-	19	0.2	1	0.064	0.9
FVA100AMVEB	RZASG100MUV			22.0	-	25	-	19	0.2	1	0.238	1.2
FDXM35F3V1B9	x3 RZASG100MUV			21.7	-	25	-	19	0.2	1	0.034 x3	0.3 x3
FDXM50F3V1B9	x2 RZASG100MUV			21.8	-	25	-	19	0.2	1	0.060 x2	0.5 x2
FHA35AVEB9	x3 RZASG100MUV			22.7	-	25	-	19	0.2	1	0.090 x3	0.6 x3
FHA50AVEB9	x2 RZASG100MUV			22.0	-	25	-	19	0.2	1	0.090 x2	0.6 x2
FHA100AVEB9	RZASG100MUV			22.2	-	25	-	19	0.2	1	0.172	1.3

4D148942

RZASG125-140MV

Indoor	Outdoor	Power supply	Voltage range	MCA	TOCA	MFA	Compressor		OFM		IFM	
							MSC	RLA	kW	FLA	kW	FLA
FCAG35BVEB	x4 RZASG125MUV	50Hz ~ 220-240V	Minimum: -198 V- Maximum -264 V-	28.0	-	32	-	24.7	0.2	1	0.044 x4	0.3 x4
FCAG50BVEB	x3 RZASG125MUV			27.7	-	32	-	24.7	0.2	1	0.039 x3	0.3 x3
FCAG60BVEB	x2 RZASG125MUV			27.4	-	32	-	24.7	0.2	1	0.044 x2	0.3 x2
FCAG125BVEB	RZASG125MUV			27.8	-	32	-	24.7	0.2	1	0.168	1
FFA35A2VEB9	x4 RZASG125MUV			28.4	-	32	-	24.7	0.2	1	0.050 x4	0.4 x4
FFA50A2VEB9	x3 RZASG125MUV			28.0	-	32	-	24.7	0.2	1	0.050 x3	0.4 x3
FFA60A2VEB9	x2 RZASG125MUV			28.0	-	32	-	24.7	0.2	1	0.050 x2	0.6 x2
FBA35A2VEB9	x4 RZASG125MUV			29.2	-	32	-	24.7	0.2	1	0.089 x4	0.6 x4
FBA50A2VEB9	x3 RZASG125MUV			28.6	-	32	-	24.7	0.2	1	0.089 x3	0.6 x3
FBA60A2VEB9	x2 RZASG125MUV			27.8	-	32	-	24.7	0.2	1	0.070 x2	0.5 x2
FBA125A2VEB9	RZASG125MUV			28.3	-	32	-	24.7	0.2	1	0.187	1.5
FNA35A2VEB9	x4 RZASG125MUV			28.0	-	32	-	24.7	0.2	1	0.034 x4	0.3 x4
FNA50A2VEB9	x3 RZASG125MUV			28.3	-	32	-	24.7	0.2	1	0.060 x3	0.5 x3
FNA60A2VEB9	x2 RZASG125MUV			27.8	-	32	-	24.7	0.2	1	0.060 x2	0.5 x2
FUA125AVEB9	RZASG125MUV			28.2	-	32	-	24.7	0.2	1	0.106	1.4
FDA125A5VEB	RZASG125MUV			28.9	-	32	-	24.7	0.2	1	0.35	2.1
FVA125AMVEB	RZASG125MUV			28.0	-	32	-	24.7	0.2	1	0.238	1.2
FDXM35F3V1B9	x4 RZASG125MUV			28.0	-	32	-	24.7	0.2	1	0.034 x4	0.3 x4
FDXM50F3V1B9	x3 RZASG125MUV			28.3	-	32	-	24.7	0.2	1	0.060 x3	0.5 x3
FDXM60F3V1B9	x2 RZASG125MUV			27.8	-	32	-	24.7	0.2	1	0.060 x2	0.5 x2
FHA35AVEB9	x4 RZASG125MUV			29.2	-	32	-	24.7	0.2	1	0.090 x4	0.6 x4
FHA50AVEB9	x3 RZASG125MUV			28.6	-	32	-	24.7	0.2	1	0.090 x3	0.6 x3
FHA60AVEB9	x2 RZASG125MUV			28.0	-	32	-	24.7	0.2	1	0.091 x2	0.6 x2
FHA125AVEB9	RZASG125MUV			28.3	-	32	-	24.7	0.2	1	0.217	1.5
FCAG35BVEB	x4 RZASG140MUV			27.2	-	32	-	24	0.2	1	0.044 x4	0.3 x4
FCAG50BVEB	x3 RZASG140MUV			26.9	-	32	-	24	0.2	1	0.039 x3	0.3 x3
FCAG71BVEB	x2 RZASG140MUV			26.8	-	32	-	24	0.2	1	0.054 x2	0.4 x2
FCAG140BVEB	RZASG140MUV			27.0	-	32	-	24	0.2	1	0.168	1
FFA35A2VEB9	x4 RZASG140MUV			27.7	-	32	-	24	0.2	1	0.050 x4	0.4 x4
FFA50A2VEB9	x3 RZASG140MUV			27.2	-	32	-	24	0.2	1	0.050 x3	0.4 x3
FBA35A2VEB9	x4 RZASG140MUV			28.5	-	32	-	24	0.2	1	0.089 x4	0.6 x4
FBA50A2VEB9	x3 RZASG140MUV			27.9	-	32	-	24	0.2	1	0.089 x3	0.6 x3
FBA71A2VEB9	x2 RZASG140MUV			27.0	-	32	-	24	0.2	1	0.070 x2	0.5 x2
FBA140A2VEB9	RZASG140MUV			27.6	-	32	-	24	0.2	1	0.187	1.5
FNA35A2VEB9	x4 RZASG140MUV			27.2	-	32	-	24	0.2	1	0.034 x4	0.3 x4
FNA50A2VEB9	x3 RZASG140MUV			27.6	-	32	-	24	0.2	1	0.060 x3	0.5 x3
FUA71AVEB9	x2 RZASG140MUV			27.9	-	32	-	24	0.2	1	0.046 x2	0.9 x2
FAA71BUV1B	x2 RZASG140MUV			26.8	-	32	-	24	0.2	1	0.048 x2	0.5 x2
FVA71AMVEB	x2 RZASG140MUV			27.2	-	32	-	24	0.2	1	0.117 x2	0.6 x2
FVA140AMVEB	RZASG140MUV			27.5	-	32	-	24	0.2	1	0.276	1.4
FDXM35F3V1B9	x4 RZASG140MUV			27.2	-	32	-	24	0.2	1	0.034 x4	0.3 x4
FDXM50F3V1B9	x3 RZASG140MUV			27.6	-	32	-	24	0.2	1	0.060 x3	0.5 x3
FHA35AVEB9	x4 RZASG140MUV			28.5	-	32	-	24	0.2	1	0.090 x4	0.6 x4
FHA50AVEB9	x3 RZASG140MUV			27.9	-	32	-	24	0.2	1	0.090 x3	0.6 x3
FHA71AVEB9	x2 RZASG140MUV			27.7	-	32	-	24	0.2	1	0.110 x2	0.8 x2
FHA140AVEB9	RZASG140MUV	27.9	-	32	-	24	0.2	1	0.251	1.8		

4D148942



RZASG71-100MY

Indoor	Outdoor	Power supply	Voltage range	MCA	TOCA	MFA	Compressor		OFM		IFM	
							MSC	RLA	kW	FLA	kW	FLA
FCAG35BVEB	x3	3N~ 50Hz 380-415V	Minimum: -342 V- Maximum -456 V-	13.0	-	16	-	10.6	0.2	1	0.044 x3	0.3 x3
FCAG50BVEB	x2			12.7	-	16	-	10.6	0.2	1	0.039 x3	0.3 x2
FCAG100BVEB				14.2	-	16	-	12	0.2	1	0.117	0.7
FFA35A2VEB9	x3			13.3	-	16	-	10.6	0.2	1	0.050 x3	0.4 x3
FFA50A2VEB9	x2			12.9	-	16	-	10.6	0.2	1	0.050 x2	0.4 x2
FBA35A2VEB9	x3			13.9	-	16	-	10.6	0.2	1	0.089 x3	0.6 x3
FBA50A2VEB9	x2			13.3	-	16	-	10.6	0.2	1	0.089 x2	0.6 x2
FBA100A2VEB9				14.6	-	16	-	12	0.2	1	0.127	1
FNA35A2VEB9	x3			13.0	-	16	-	10.6	0.2	1	0.034 x3	0.3 x3
FNA50A2VEB9	x2			13.1	-	16	-	10.6	0.2	1	0.060 x2	0.5 x2
FUA100AVEB9				14.9	-	16	-	12	0.2	1	0.106	1.3
FAA100BUV1B				14.4	-	16	-	12	0.2	1	0.064	0.9
FVA100AMVEB				14.8	-	16	-	12	0.2	1	0.238	1.2
FDXM35F3V1B9	x3			13.0	-	16	-	10.6	0.2	1	0.034 x3	0.3 x3
FDXM50F3V1B9	x2			13.1	-	16	-	10.6	0.2	1	0.060 x2	0.5 x2
FHA35AVEB9	x3			13.9	-	16	-	10.6	0.2	1	0.090 x3	0.6 x3
FHA50AVEB9	x2			13.3	-	16	-	10.6	0.2	1	0.090 x2	0.6 x2
FHA100AVEB9				14.9	-	16	-	12	0.2	1	0.172	1.3

4D148942

RZASG125-140MY

Indoor	Outdoor	Power supply	Voltage range	MCA	TOCA	MFA	Compressor		OFM		IFM	
							MSC	RLA	kW	FLA	kW	FLA
FCAG35BVEB	x4	3N~ 50Hz 380-415V	Minimum: -342 V- Maximum -456 V-	12.2	-	16	-	9.5	0.2	1	0.044 x4	0.3 x4
FCAG50BVEB	x3			13.0	-	16	-	10.6	0.2	1	0.039 x3	0.3 x3
FCAG60BVEB	x2			12.7	-	16	-	10.6	0.2	1	0.044 x2	0.3 x2
FCAG125BVEB				14.6	-	16	-	12	0.2	1	0.168	1
FFA35A2VEB9	x4			12.6	-	16	-	10.6	0.2	1	0.050 x4	0.4 x4
FFA50A2VEB9	x3			13.3	-	16	-	10.6	0.2	1	0.050 x3	0.4 x3
FFA60A2VEB9	x2			13.3	-	16	-	9.5	0.2	1	0.050 x2	0.6 x2
FBA35A2VEB9	x4			13.4	-	16	-	10.6	0.2	1	0.089 x4	0.6 x4
FBA50A2VEB9	x3			13.9	-	16	-	10.6	0.2	1	0.089 x3	0.6 x3
FBA60A2VEB9	x2			13.1	-	16	-	9.5	0.2	1	0.070 x2	0.5 x2
FBA125A2VEB9				15.1	-	16	-	10.6	0.2	1	0.187	1.5
FNA35A2VEB9	x4			12.2	-	16	-	10.6	0.2	1	0.034 x4	0.3 x4
FNA50A2VEB9	x3			13.6	-	16	-	12	0.2	1	0.060 x3	0.5 x3
FNA60A2VEB9	x2			13.1	-	16	-	10.6	0.2	1	0.060 x2	0.5 x2
FUA125AVEB9				15.0	-	16	-	10.6	0.2	1	0.106	1.4
FDA125AVEB				15.7	-	16	-	12	0.2	1	0.35	2.1
FVA125AMVEB				14.8	-	16	-	12	0.2	1	0.238	1.2
FDXM35F3V1B9	x4			12.2	-	16	-	12	0.2	1	0.034 x4	0.3 x4
FDXM50F3V1B9	x3			13.6	-	16	-	9.5	0.2	1	0.060 x3	0.5 x3
FDXM60F3V1B9	x2			13.1	-	16	-	10.6	0.2	1	0.060 x2	0.5 x2
FHA35AVEB9	x4	13.4	-	16	-	10.6	0.2	1	0.090 x4	0.6 x4		
FHA50AVEB9	x3	13.9	-	16	-	9.5	0.2	1	0.090 x3	0.6 x3		
FHA60AVEB9	x2	13.3	-	16	-	10.6	0.2	1	0.091 x2	0.6 x2		
FHA125AVEB9		15.1	-	16	-	12	0.2	1	0.217	1.5		
FCAG35BVEB	x4	3N~ 50Hz 380-415V	Minimum: -342 V- Maximum -456 V-	12.2	-	16	-	9.5	0.2	1	0.044 x4	0.3 x4
FCAG50BVEB	x3			12.9	-	16	-	10.5	0.2	1	0.039 x3	0.3 x3
FCAG71BVEB	x2			14.4	-	16	-	12	0.2	1	0.054 x2	0.4 x2
FCAG140BVEB				14.6	-	16	-	12	0.2	1	0.168	1
FFA35A2VEB9	x4			12.6	-	16	-	9.5	0.2	1	0.050 x4	0.4 x4
FFA50A2VEB9	x3			13.2	-	16	-	10.5	0.2	1	0.050 x3	0.4 x3
FBA35A2VEB9	x4			13.4	-	16	-	9.5	0.2	1	0.089 x4	0.6 x4
FBA50A2VEB9	x3			13.8	-	16	-	10.5	0.2	1	0.089 x3	0.6 x3
FBA71A2VEB9	x2			14.6	-	16	-	12	0.2	1	0.070 x2	0.5 x2
FBA140A2VEB9				15.1	-	16	-	12	0.2	1	0.187	1.5
FNA35A2VEB9	x4			12.2	-	16	-	9.5	0.2	1	0.034 x4	0.3 x4
FNA50A2VEB9	x3			13.5	-	16	-	10.5	0.2	1	0.060 x3	0.5 x3
FUA71AVEB9	x2			15.4	-	16	-	12	0.2	1	0.046 x2	0.9 x2
FAA71BUV1B	x2			14.4	-	16	-	12	0.2	1	0.048 x2	0.5 x2
FVA71AMVEB	x2			14.8	-	16	-	12	0.2	1	0.117 x2	0.6 x2
FVA140AMVEB				15.0	-	16	-	12	0.2	1	0.276	1.4
FDXM35F3V1B9	x4			12.2	-	16	-	9.5	0.2	1	0.034 x4	0.3 x4
FDXM50F3V1B9	x3			13.5	-	16	-	10.5	0.2	1	0.060 x3	0.5 x3
FHA35AVEB9	x4			13.4	-	16	-	9.5	0.2	1	0.090 x4	0.6 x4
FHA50AVEB9	x3			13.8	-	16	-	10.5	0.2	1	0.090 x3	0.6 x3
FHA71AVEB9	x2	15.2	-	16	-	12	0.2	1	0.110 x2	0.8 x2		
FHA140AVEB9		15.4	-	16	-	12	0.2	1	0.251	1.8		

4D148942



DETAILED TECHNICAL DRAWINGS

RZASG-MV/MY

Symbols			Notes
MCA	Minimum Circuit Ampere	[A]	1 The -RLA- is based on the following conditions. Cooling Indoor temperature -27.0°C DB / -19.0°C WB Outdoor temperature -35.0°C DB Heating Indoor temperature -20.0°C DB Outdoor temperature -7.0°C DB / -6.0°C WB 2 -TOCA- is the total value of each overcurrent set. 3 Voltage range The units are suitable for use with electrical systems in which the voltage supplied to the unit terminals is not below or above the listed range limits. 4 The maximum allowable voltage that is unbalanced between phases is -2%. 5 -MCA- is the maximum input current. The capacity of the -MFA- must be greater than that of the -MCA-. Select the -MFA- according to the table. 6 Select the wire size according to the MCA. 7 -MFA- is used to select the circuit breaker and the ground fault circuit interruptor. Earth leakage circuit breaker
TOCA	Total overcurrent amps	[A]	
MFA	Maximum Fuse Ampere	[A]	
MSC	Maximum current of the starting compressor	[A]	
RLA	Rated load amps	[A]	
OFM	Outdoor fan motor		
IFM	Indoor fan motor		
FLA	Full Load Ampere	[A]	
KW	Fan motor rated output	[kW]	

4D148942

RZASG-MV/MY

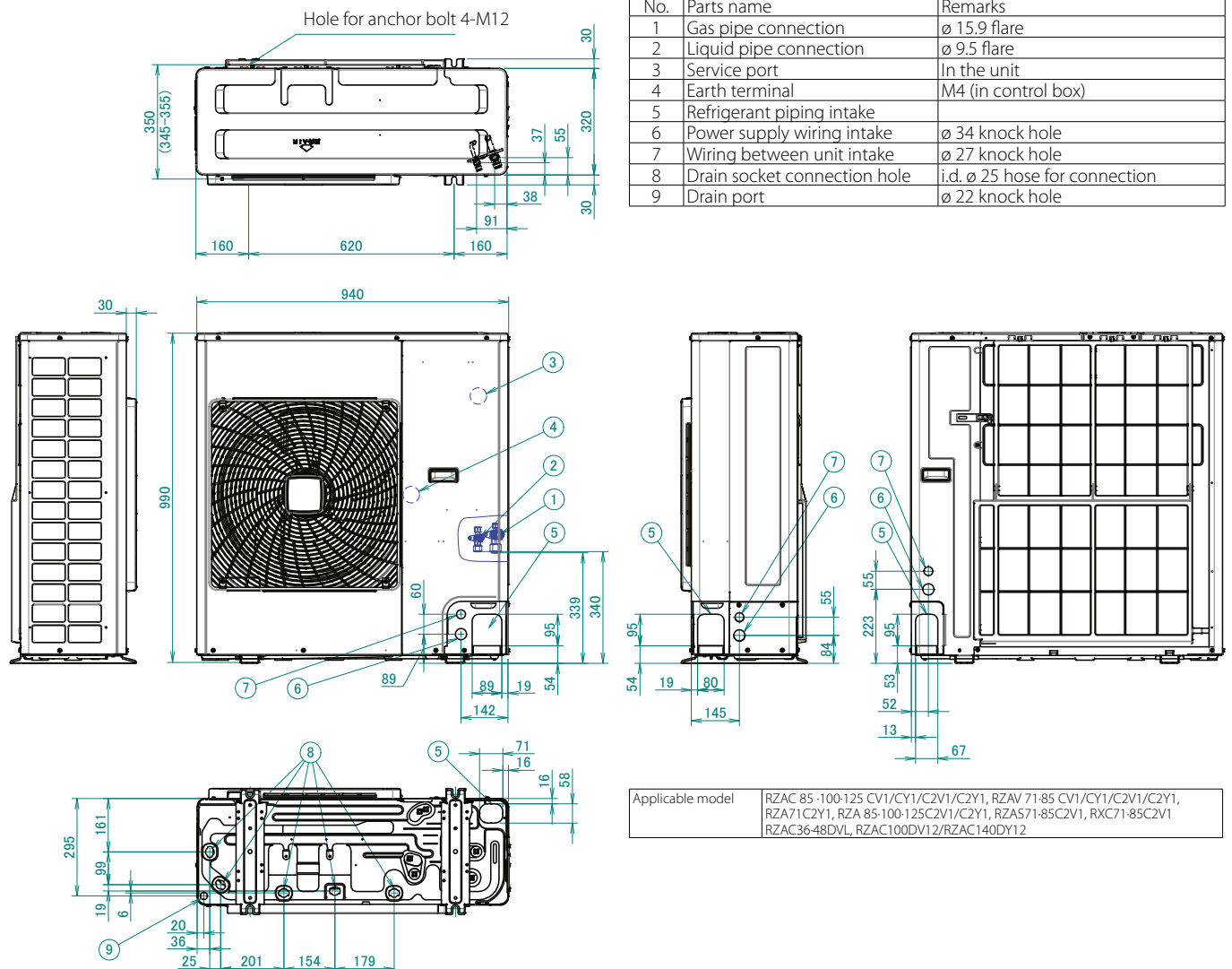

3D121881D



RZASG-MV/MY

Installation servicing space

(The unit of the values is mm.)

Installation of single unit

When nothing is obstructing the top

- (1) In case obstacles exist only in front of the air inlet. (2) In case obstacles exist in front of the air inlet and on both sides of the unit. (3) In case obstacles exist only in front of outlet side.

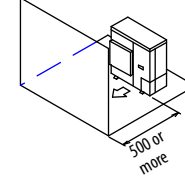
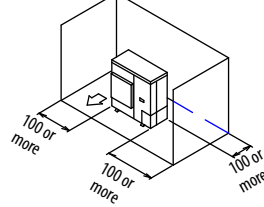
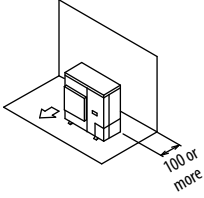

When something is obstructing the top

- (1) In case obstacles exist in front of the air inlet. (2) In case obstacles exist in front of the air inlet and on both sides of the unit. (3) In case obstacles exist in front of outlet side.

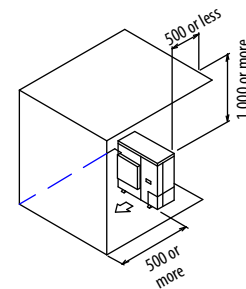
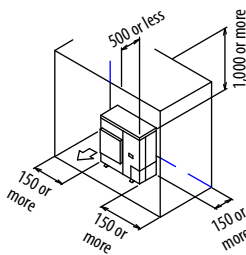
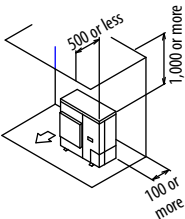

In case obstacles exist in front of both the air inlet and outlet sides

Pattern 1 Where obstacle in front of the air outlet is higher than the unit.

- (1) When nothing is obstructing the top. (There is no height limit for obstructions on the intake side.)

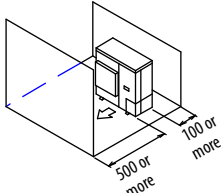

- (2) When something is obstructing the top. Relation of dimensions of H, A, and L are shown in the table below

	L	A
$L \leq H$	$0 < L \leq 1/2H$	750 or more
	$1/2H < L \leq H$	1,000 or more
$L > H$	Set the frame to be $L \leq H$. Refer to the column of $L \leq H$ for A.	

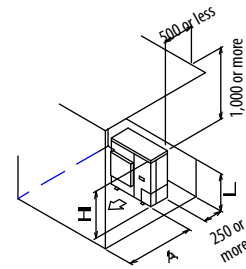

Pattern 2 Where obstacles in front of the air outlet is lower than the unit.

- (1) When nothing is obstructing the top. (There is no height limit for obstructions on the intake side.)

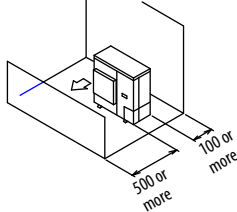

- (2) When something is obstructing the top. Relation of dimensions of H, A, and L are shown in the table below

	L	A
$L \leq H$	$0 < L \leq 1/2H$	100 or more
	$1/2H < L \leq H$	200 or more
$L > H$	Set the frame to be $L \leq H$. Refer to the column of $L \leq H$ for A.	

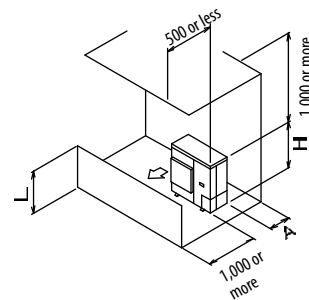

Get the lower part of the frame sealed so that air from the outlet does not bypass.

IN CASE OF INSTALLING MULTIPLE UNITS (2 UNITS OR MORE) IN LATERAL CONNECTION PER ROW

- Secure appropriate space when using a side piping outlet.

When nothing is obstructing the top

- (1) In case obstacles exist in front of the air inlet and on both sides of the unit. (2) In case obstacles exist only in front of outlet side.

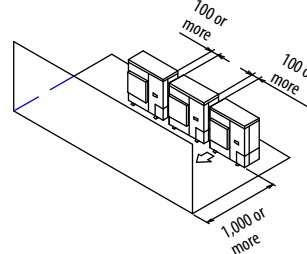
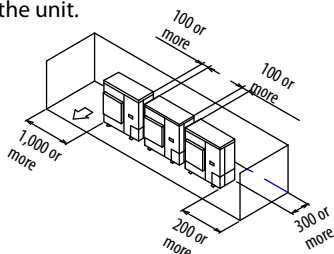

RZASG-MV/MY

When something is obstructing the top

(1) In case obstacles exist in front of outlet side.

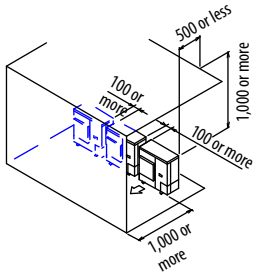

(2) In case obstacles exist in front of the air inlet and on both sides of the unit.

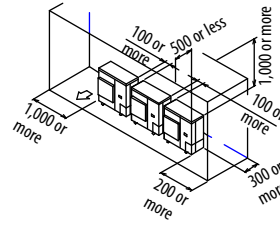

In case obstacles exist in front of both the air inlet and outlet sides

Pattern 1 Where obstacle in front of the air outlet is higher than the unit.

(1) When nothing is obstructing the top.

(There is no height limit for obstructions on the intake side.)

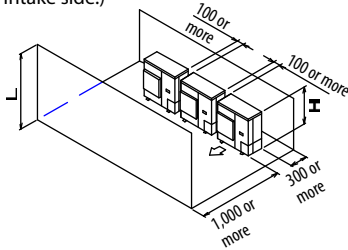

(2) When something is obstructing the top.

Relation of dimensions of H, A, and L are shown in the table below

	L	A
$L \leq H$	$0 < L \leq 1/2H$	1,000 or more
	$1/2H < L \leq H$	1,250 or more
$L > H$	Set the frame to be $L \leq H$. Refer to the column of $L \leq H$ for A.	

Get the lower part of the frame sealed so that air from the outlet does not bypass.

Only two units at most can be installed in series

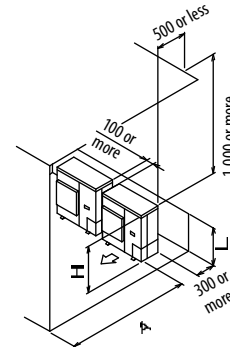

Pattern 2 Where obstacles in front of the air outlet is lower than the unit.

(1) When nothing is obstructing the top.

(There is no height limit for obstructions on the intake side.)

L	A
$0 < L \leq 1/2H$	250 or more
$1/2H < L \leq H$	300 or more

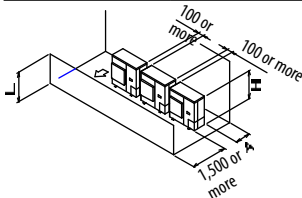

(2) When something is obstructing the top.

Relation of dimensions of H, A, and L are shown in the table below

	L	A
$L \leq H$	$0 < L \leq 1/2H$	250 or more
	$1/2H < L \leq H$	300 or more
$L > H$	Set the frame to be $L \leq H$. Refer to the column of $L \leq H$ for A.	

Get the lower part of the frame sealed so that air from the outlet does not bypass.

Only two units at most can be installed in series.

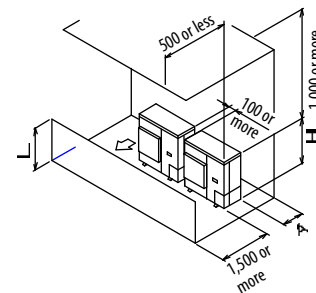

IN CASE OF STACKED INSTALLATION

(1) In case obstacles exist in front of outlet side.

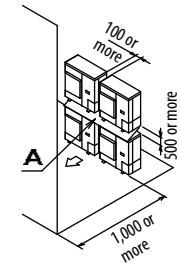

(2) In case obstacles exist in front of the air inlet.

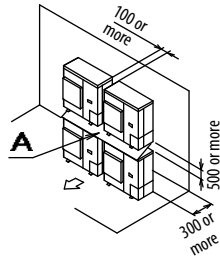

- Do not exceed two levels for stacked installation.
- Install a roof cover similar to A (field supply), as outdoor units with downward drainage are prone to dripping and freezing.
- Install the upper-level outdoor unit so that its bottom plate is a sufficient height above the roof cover. This is to prevent the buildup of ice on the underside of the bottom plate. (A space of at least 500 mm is recommended.)
- It is not necessary to install a roof cover if there is no danger of drainage dripping and freezing. In this case, the space between the upper and lower outdoor units should be at least 100 mm. (Close off the gap between the upper and lower units so there is no re-intake of discharged air.)

IN CASE OF MULTIPLE-ROW INSTALLATION (FOR ROOF TOP USE, ETC.)

(1) In case of installing one unit per row.

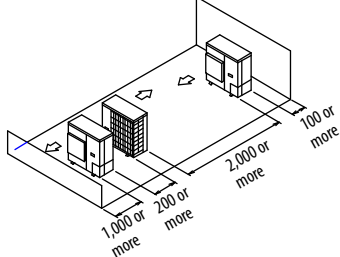

(2) When something is obstructing the top.

Relation of dimensions of H, A, and L are shown in the table below

	L	A
$L \leq H$	$0 < L \leq 1/2H$	250 or more
	$1/2H < L \leq H$	300 or more
$L > H$	Installation impossible	

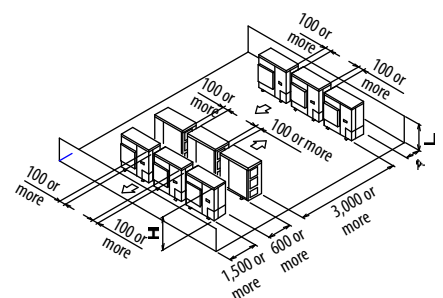



RZASG-MV/MY

To determine if adding additional refrigerant is necessary

if	Then
$(L1+L2+L3+L4+L5+L6+L7) \leq 30$ m (chargeless length)	You do not have to add additional refrigerant.
$(L1+L2+L3+L4+L5+L6+L7) > 30$ m (chargeless length)	You must add additional refrigerant. For future servicing, encircle the selected amount in the tables below.

INFORMATION

Piping length is the largest one way length of liquid piping.

To determine the additional refrigerant amount (R in kg) (in case of pair)

	L1 (m)	
	30~40 m	40~50 m
L1:		
R:	0.35 kg	0.7 kg

To determine the additional refrigerant amount (R in kg) (in case of twin, triple and double twin)

1. Determine R1 and R2.

if	Then
$G1 > 30$ m	Use the table below to determine R1
$G1 \leq 30$ m (and $G1+G2 > 30$ m)	$R1 = 0.0$ kg. Use the table below to determine R2.

	Length (total length of liquid piping - 30 m)				
	0~10 m	10~20 m	20~30 m	30~40 m	40~45 m
R1:	0.35 kg	0.7 kg	1.05 kg ^(a)	1.4 kg ^(a)	
R2:	0.2 kg	0.4 kg	0.6 kg	0.8 kg ^(a)	1 kg ^(b)

a) Only for RZASG100~140.

b) Only for RZASG100+125.

2. Determine the additional refrigerant amount: $R=R1+R2$.

Examples

Layout	Additional refrigerant amount (R)	
<p>RZASG100</p>	Case: Twin, standard liquid pipe size	
	1.	G1 Total Ø9.5 => G1=35 m G2 Total Ø6.4 => G2=7+5=12 m
	2.	Case: $G1 > 30$ m R1 Length= $G1-30$ m=5 m => $R1=0.35$ kg R2 Length= $G2=12$ m => $R2=0.4$ kg
<p>RZASG125</p>	Case: Triple, standard liquid pipe size	
	1.	G1 Total Ø9.5 => G1=5 m G2 Total Ø6.4 => G2=15+12+17=44 m
	2.	Case: $G1 \leq 30$ m (and $G1+G2 > 30$ m) R1 $R1=0.0$ kg R2 Length= $G1+G2-30$ m = 5+44-30=19 m => $R2=0.4$ kg
	3.	R $R=R1+R2=0.0+0.4=0.4$ kg

4PEN485928-1D_2019_04

DETAILED TECHNICAL DRAWINGS

RZA-D

Indoor	Outdoor	Power supply	Voltage range		MCA	TOCA	MFA	Compressor		OFM		IFM			
			Minimum	Maximum				MSC	RLA	kW	FLA	FLA			
FDA200A2VEB	RZA200D7Y1B	3N~ 50Hz 380-415V	Minimum: -342 V-	Maximum -457 V-	16.9	-	20	-	14.0	0.6	1.3	4.0			
FCAG50BVEB	x4 RZA200D7Y1B				16.1	-	20	-	13.0	0.6	1.3	0.3 x4			
FCAG60BVEB	x3 RZA200D7Y1B				16.7	-	20	-	13.9	0.6	1.3	0.3 x3			
FCAG71BVEB	x3 RZA200D7Y1B				16.7	-	20	-	13.9	0.6	1.3	0.3 x3			
FCAG100BVEB	x2 RZA200D7Y1B				16.4	-	20	-	13.1	0.6	1.3	0.7 x2			
FFA50A2VEB	x4 RZA200D7Y1B				16.5	-	20	-	13.0	0.6	1.3	0.4 x4			
FFA60A2VEB	x3 RZA200D7Y1B				17.7	-	20	-	13.9	0.6	1.3	0.6 x3			
FBA50A2VEB	x4 RZA200D7Y1B				20.5	-	20	-	13.0	0.6	1.3	1.4 x4			
FBA60A2VEB	x3 RZA200D7Y1B				19.7	-	20	-	13.9	0.6	1.3	1.3 x3			
FBA71A2VEB	x3 RZA200D7Y1B				19.7	-	20	-	13.9	0.6	1.3	1.3 x3			
FBA100A2VEB	x2 RZA200D7Y1B				22	-	20	-	13.1	0.6	1.3	3.5 x2			
FHA50AVEB98	x4 RZA200D7Y1B				17.4	-	20	-	13.0	0.6	1.3	0.6 x4			
FHA60AVEB98	x3 RZA200D7Y1B				17.7	-	20	-	13.9	0.6	1.3	0.6 x3			
FHA71AVEB98	x3 RZA200D7Y1B				18.3	-	20	-	13.9	0.6	1.3	0.8 x3			
FHA100AVEB8	x2 RZA200D7Y1B				17.7	-	20	-	13.1	0.6	1.3	1.3 x2			
FUA71AVEB	x3 RZA200D7Y1B				18.6	-	20	-	13.9	0.6	1.3	0.9 x3			
FUA100AVEB	x2 RZA200D7Y1B				17.7	-	20	-	13.1	0.6	1.3	1.3 x2			
FAA71BUV1B	x3 RZA200D7Y1B				17.4	-	20	-	13.9	0.6	1.3	0.5 x3			
FAA100BUV1B	x2 RZA200D7Y1B				16.8	-	20	-	13.1	0.6	1.3	0.9 x2			
FVA71AMVEB	x3 RZA200D7Y1B				18.3	-	20	-	13.9	0.6	1.3	0.8 x3			
FVA100AMVEB	x2 RZA200D7Y1B				18.1	-	20	-	13.1	0.6	1.3	1.5 x2			
FDXM50F3V1B	x4 RZA200D7Y1B				18.6	-	20	-	13.0	0.6	1.3	0.9 x4			
FDXM60F3V1B	x3 RZA200D7Y1B				18.6	-	20	-	13.9	0.6	1.3	0.9 x3			
FNA50A2VEB	x4 RZA200D7Y1B				17.0	-	20	-	13.0	0.6	1.3	0.5 x4			
FNA60A2VEB	x3 RZA200D7Y1B				17.7	-	20	-	13.9	0.6	1.3	0.6 x3			
FDA250A2VEB	RZA250D7Y1B				3N~ 50Hz 380-415V	Minimum: -342 V-	Maximum -457 V-	20.2	-	20	-	14.0	0.6	1.3	4.3
FCAG60BVEB	x4 RZA250D7Y1B							17.2	-	20	-	14.0	0.6	1.3	0.3 x4
FCAG125BVEB	x2 RZA250D7Y1B							18.2	-	20	-	13.6	0.6	1.3	1.3 x2
FFA60A2VEB	x4 RZA250D7Y1B							18.4	-	20	-	14.0	0.6	1.3	0.6 x4
FBA60A2VEB	x4 RZA250D7Y1B							21.1	-	20	-	14.0	0.6	1.3	1.3 x4
FBA125A2VEB	x2 RZA250D7Y1B	22.7	-	20				-	13.6	0.6	1.3	3.6 x2			
FHA60AVEB98	x4 RZA250D7Y1B	18.4	-	20				-	14.0	0.6	1.3	0.6 x4			
FHA125AVEB98	x2 RZA250D7Y1B	18.6	-	20				-	13.6	0.6	1.3	1.5 x2			
FUA125AVEB	x2 RZA250D7Y1B	18.4	-	20				-	13.6	0.6	1.3	1.4 x2			
FDA125A2VEB	x2 RZA250D7Y1B	19.9	-	20				-	13.6	0.6	1.3	2.1 x2			
FVA125AMVEB	x2 RZA250D7Y1B	18.6	-	20				-	13.6	0.6	1.3	1.5 x2			
FDXM60F3V1B	x4 RZA250D7Y1B	19.7	-	20				-	14.0	0.6	1.3	0.9 x4			
FNA60A2VEB	x4 RZA250D7Y1B	18.4	-	20				-	14.0	0.6	1.3	0.6 x4			

3D125194C

RZA-D

Symbols	Notes
MCA Minimum Circuit Ampere [A]	1 The -RLA- is based on the following conditions. Cooling Indoor temperature -27.0°C DB / -19.0°C WB Outdoor temperature -35.0°C DB Heating Indoor temperature -20.0°C DB Outdoor temperature -7.0°C DB / -6.0°C WB 2 -TOCA- is the total value of each overcurrent set. 3 Voltage range The units are suitable for use with electrical systems in which the voltage supplied to the unit terminals is not below or above the listed range limits. 4 The maximum allowable voltage that is unbalanced between phases is -2%. 5 -MCA- is the maximum input current. The capacity of the -MFA- must be greater than that of the -MCA-. Select the -MFA- according to the table. 6 Select the wire size according to the MCA. 7 -MFA- is used to select the circuit breaker and the ground fault circuit interruptor. Earth leakage circuit breaker
TOCA Total overcurrent amps [A]	
MFA Maximum Fuse Ampere [A]	
MSC Maximum current of the starting compressor [A]	
RLA Rated load amps [A]	
OFM Outdoor fan motor	
IFM Indoor fan motor	
FLA Full Load Ampere [A]	
kW Fan motor rated output [kW]	

3D125194C



RZA-D

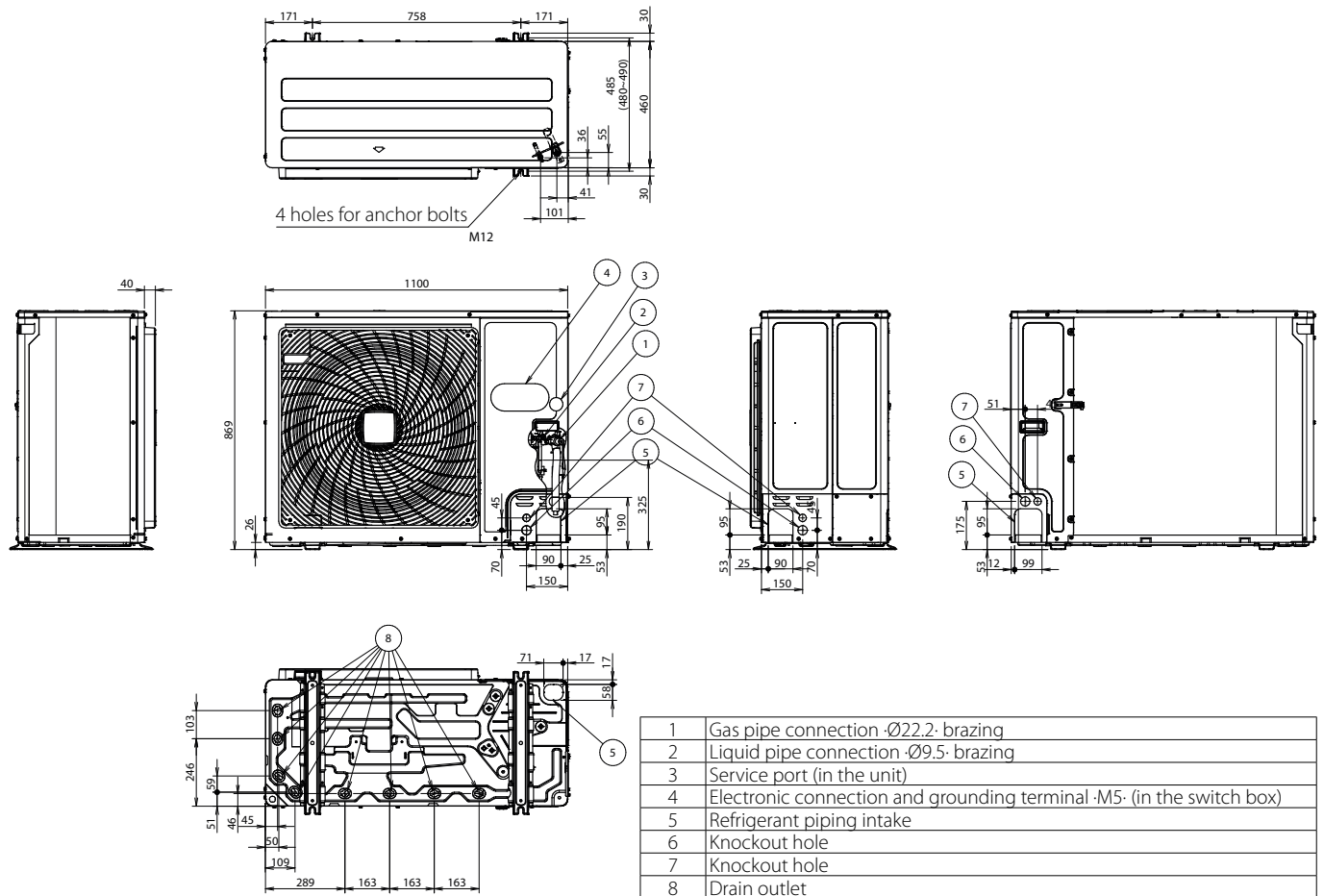

3D120937

**RZAG-NV1/NY1
RZA-D**

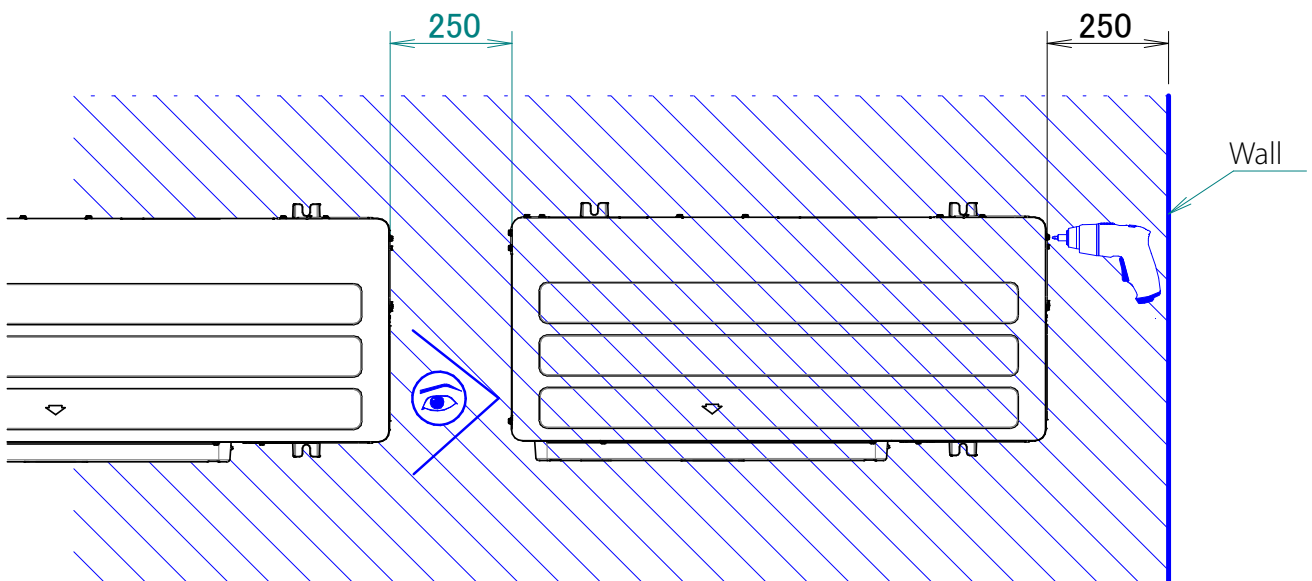

* For optimal serviceability, provide ·250·mm of free space.
For more installation and service space guidelines, see drawing ·3D069554·.

3D120935

DETAILED TECHNICAL DRAWINGS

**RZAG-NV1/NY1
RZA-D**

Suction side	In the illustrations below, the service space at the suction side is based on 35°C DB and cooling operation. Foresee more space in the following cases: • When the suction side temperature regularly exceeds this temperature. • When the heat load of the outdoor units is expected to regularly exceed the maximum operating capacity.
Discharge side	Take refrigerant piping work into account when positioning the units. If your layout does not match with any of the layouts below, contact your dealer.

Single unit | Single row of units

	A~E	H _B H _D H _U	(mm)								
			a	b	c	d	e	e _B		e _D	
	B	—		≥100							
	A, B, C	—	≥100 ⁽¹⁾	≥100	≥100						
	B, E	—		≥100			≥1,000			≤500	
	A, B, C, E	—	≥150 ⁽¹⁾	≥150	≥150		≥1,000			≤500	
	D	—				≥500					
	D, E	—				≥500	≥1,000	≥500			
	B, D	H _D >H _U H _D ≤H _U		≥100		≥500					
	B, D, E	H _D >H _U	H _B ≤½H _U	≥250		≥750	≥1,000	≤500			1
			½H _U <H _B ≤H _U	≥250		≥1,000	≥1,000	≤500			
		H _D ≤H _U	H _B >H _U	⊘							
H _B ≤½H _U			≥100		≥1,000	≥1,000		≤500			
		½H _U <H _B ≤H _U	≥200		≥1,000	≥1,000		≤500			
		H _D >H _U	⊘								
	A, B, C	—	≥200 ⁽¹⁾	≥300	≥1,000						
	A, B, C, E	—	≥200 ⁽¹⁾	≥300	≥1,000		≥1,000			≤500	
	D	—				≥1,000					
	D, E	—				≥1,000	≥1,000	≤500			
	B, D	H _D >H _U H _D ≤H _U	H _B ≤½H _U	≥300		≥1,000					
			½H _U <H _B ≤H _U	≥300		≥1,500					
	B, D, E	H _D >H _U	H _B ≤½H _U	≥300		≥1,000	≥1,000	≤500			1+2
			½H _U <H _B ≤H _U	≥300		≥1,250	≥1,000	≤500			
		H _D ≤H _U	H _B >H _U	⊘							
			H _B ≤½H _U	≥250		≥1,500	≥1,000		≤500		
		½H _U <H _B ≤H _U	≥300		≥1,500	≥1,000		≤500			
		H _D >H _U	⊘								

(1) For better serviceability, use a distance ≥250 mm

A,B,C,D Obstacles (walls/baffle plates)

E Obstacle (roof)

a,b,c,d,e Minimum service space between the unit and obstacles A, B, C, D and E

eB Maximum distance between the unit and the edge of obstacle E, in the direction of obstacle B

eD Maximum distance between the unit and the edge of obstacle E, in the direction of obstacle D

HU Height of the unit

HB,HD Height of obstacles B and D

1 Seal the bottom of the installation frame to prevent discharged air from flowing back to the suction side through the bottom of the unit.

2 Maximum two units can be installed.

⊘ Not allowed



RZAG-NV1/NY1
RZA-D

Multiple rows of units

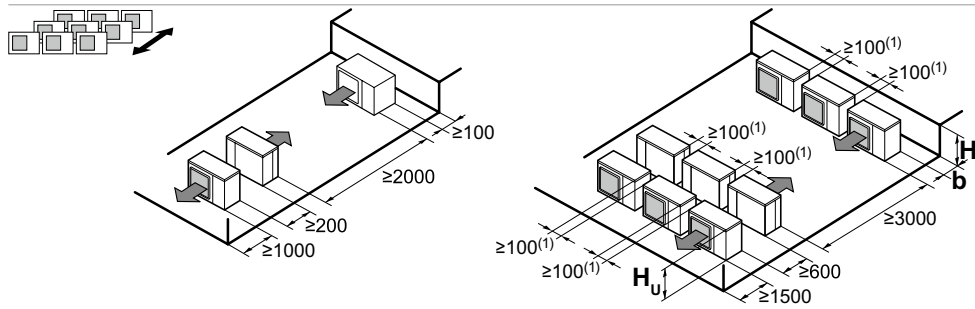

H_b, H_u	b (mm)
$H_b \leq H_u$	$b \geq 250$
$\frac{1}{2}H_b < H_b \leq H_u$	$b \geq 300$
$H_b > H_u$	⊘

(1) For better serviceability, use a distance ≥ 250 mm

Stacked units (max. 2 levels)

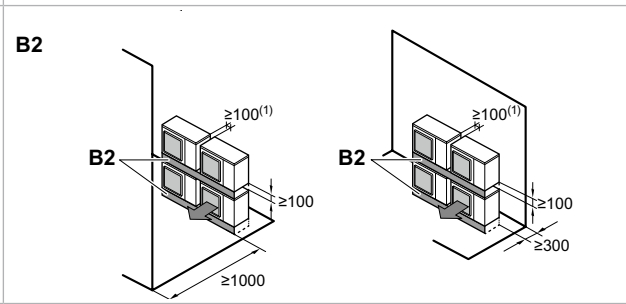
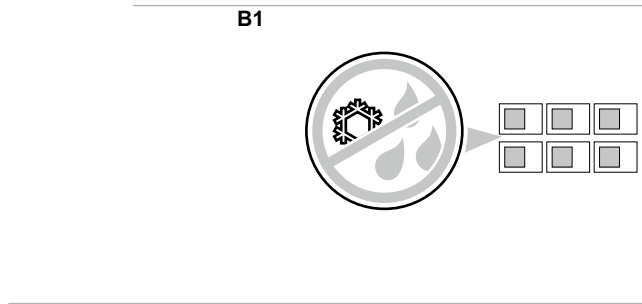
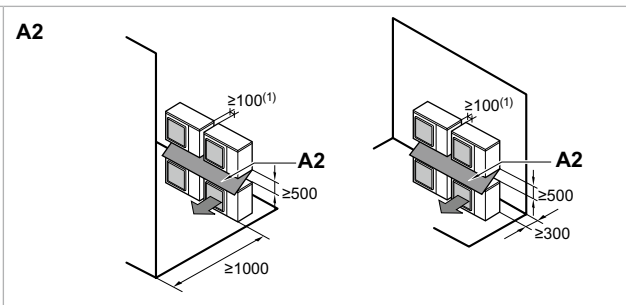
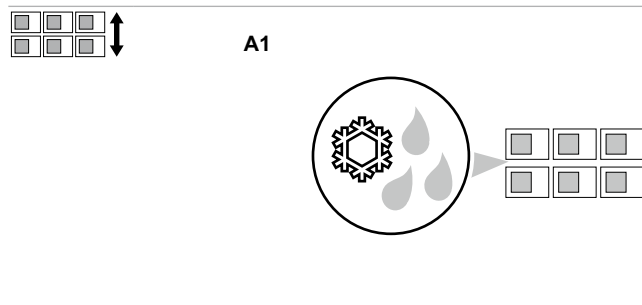

(1) For better serviceability, use a distance ≥ 250 mm

A1=>A2 (A1) If there is danger of drainage dripping and freezing between the upper and lower units...

(A2) Then install a roof between the upper and lower units. Install the upper unit high enough above the lower unit to prevent ice buildup at the upper unit's bottom plate.

B1=>B2 (B1) If there is no danger of drainage dripping and freezing between the upper and lower units...

(B2) Then it is not required to install a roof, but seal the gap between the upper and lower units to prevent discharged air from flowing back to the suction side through the bottom of the unit.

RZA-D

To determine the additional refrigerant amount

To determine if adding additional refrigerant is necessary

Chargeless length	
Ø standard	30 m
Ø size-up of gas piping	30 m
Ø size-up of liquid piping	20 m
if	Then
$(L1+L2+L3+L4+L5+L6+L7) \leq$ chargeless length	You do not have to add additional refrigerant.
$(L1+L2+L3+L4+L5+L6+L7) >$ chargeless length	You must add additional refrigerant. For future servicing, encircle theselected amount in the tables below.

INFORMATION

Piping length is the largest one-way length of liquid piping.

To determine the additional refrigerant amount (R in kg) (in case of pair)

Standard piping size:

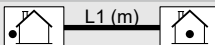
								
L1:		30~40 m	40~50 m	50~60 m	60~70 m	70~80 m	80~90 m	90~100 m
R:		0.45 kg	0.9 kg	1.35 kg	1.8 kg	2.25 kg	2.7 kg	3.15 kg

Size-up piping size:

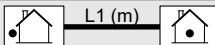
							
L1:		20~25 m	25~30 m	30~35 m	35~40 m	40~45 m	40~45m
R:		0.35 kg	0.7 kg	1.05 kg ^(a)	1.4 kg ^(a)	1.75 kg	2.1 kg

To determine the additional refrigerant amount (R in kg) (in case of twin, triple and double twin)

1. Determine G1 and G2.

G1 (m)	Total length of <x> liquid piping x=Ø9.5 mm (standard) x=Ø12.7 mm (size-up)
G2 (m)	Total length of Ø6.4 mm liquid piping

2. Determine R1 and R2.

if	Then
$G1 > 30 \text{ m}^{(a)}$	Use the table below to determine R1 (length=G1-30 m) ^(a) and R2 (length=G2). R1=0.0 kg.
$G1 \leq 30 \text{ m}^{(a)}$ (and $G1+G2 > 30 \text{ m}^{(a)}$)	Use the table below to determine R2 (length=G1+G2-30 m) ^(a) .

(a) In case of size-up: replace 30 m by 20 m.

	Standard liquid pipe size						
	Length (m)						
R1:	0~10 m	10~20 m	20~30 m	30~40 m	40~50 m	50~60 m	60~70 m
R2:	0.45 kg	0.9 kg	1.35 kg	1.8 kg	2.25 kg	2.7 kg	3.15 kg
	0.2 kg	0.4 kg	0.6 kg	0.8 kg	1 kg	1.2 kg	1.4 kg
	Size-up liquid pipe size						
	Length (m)						
R1:	0~5 m	5~10 m	10~15 m	15~20 m	20~25 m	25~30 m	
R2:	0.35 kg	0.7 kg	1.05 kg	1.1 kg	1.75 kg	2.1 kg	
	0.18 kg	0.35 kg	0.53 kg	0.7 kg	0.88 kg	1.05 kg	

3. Determine the additional refrigerant amount: R=R1+R2.

Examples

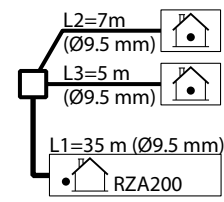
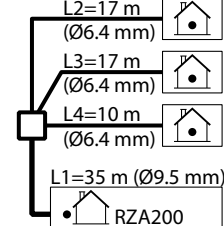
Layout	Additional refrigerant amount (R)		
	Case: Twin, standard liquid pipe size		
	1.	G1	Total Ø9.5 => G1=35+7+5=47 m
		G2	Total Ø6.4 => G2=0 m
	2.	Case: G1>30 m	
	R1	Length=G1-30 m=47-30 m=> R1=0.9 kg	
	R2	Length=G2=0 m => R2=0 kg	
3.	R	R=R1+R2=0.9+0=0.9 kg	
	Case: Triple, standard liquid pipe size		
	1.	G1	Total Ø9.5 => G1=5 m
		G2	Total Ø6.4 => G2=10+17+17=44 m
	2.	Case: G1≤30 m (and G1+G2>30 m)	
	R1	R1=0.0 kg	
	R2	Length=G1+G2-30=5+44-30=19 m => R2=0.4 kg	
3.	R	R=R1+R2=0.0+0.4=0.4 kg	



AZAS100MV

Indoor	Outdoor	Power supply	Voltage range		MCA	TOCA	MFA	Compressor		OFM		IFM	
								MSC	RLA	kW	FLA	kW	FLA
FCAG100BVEB	AZAS100MUV	50Hz ~ 220-240V	Minimum: -198 V·	Maximum -264 V·	21.5	-	25	-	19	0.2	1	0.117	0.7
FBA100A2VEB9	AZAS100MUV				21.8	-	25	-	19	0.2	1	0.127	1
FAA100BUV1B	AZAS100MUV				21.7	-	25	-	19	0.2	1	0.064	0.9
ADEA100A2VEB	AZAS100MUV				21.8	-	25	-	19	0.2	1	0.127	1
FVA100AMVEB	AZAS100MUV				22.0	-	25	-	19	0.2	1	0.238	1.2
FHA100AVEB9	AZAS100MUV				22.2	-	25	-	19	0.2	1	0.172	1.3
FCAG125BVEB	AZAS125MUV				27.8	-	32	-	24.7	0.2	1	0.168	1
FBA125A2VEB9	AZAS125MUV				28.3	-	32	-	24.7	0.2	1	0.187	1.5
ADEA125A2VEB	AZAS125MUV				28.3	-	32	-	24.7	0.2	1	0.187	1.5
FVA125AMVEB	AZAS125MUV				28.0	-	32	-	24.7	0.2	1	0.238	1.2
FHA125AVEB9	AZAS125MUV				28.3	-	32	-	24.7	0.2	1	0.217	1.5
FCAG140BVEB	AZAS140MUV				27.0	-	32	-	24	0.2	1	0.168	1
FBA140A2VEB9	AZAS140MUV				27.6	-	32	-	24	0.2	1	0.187	1.5
FVA140AMVEB	AZAS140MUV				27.5	-	32	-	24	0.2	1	0.276	1.4
FHA140AVEB9	AZAS140MUV				27.9	-	32	-	24	0.2	1	0.251	1.8
FHA35AVEB9	x3 RZASG100MUV				22.7	-	25	-	19	0.2	1	0.090 x3	0.6 x3
FHA50AVEB9	x2 RZASG100MUV				22.0	-	25	-	19	0.2	1	0.090 x2	0.6 x2
FHA100AVEB9	RZASG100MUV				22.2	-	25	-	19	0.2	1	0.172	1.3

4D148942

AZAS100MY

Indoor	Outdoor	Power supply	Voltage range		MCA	TOCA	MFA	Compressor		OFM		IFM	
								MSC	RLA	kW	FLA	kW	FLA
FCAG100BVEB	AZAS100MUY	3N~ 50Hz 380-415V	Minimum: -342 V·	Maximum -456 V·	14.2	-	16	-	12	0.2	1	0.117	0.7
FBA100A2VEB9	AZAS100MUY				14.6	-	16	-	12	0.2	1	0.127	1
FAA100BUV1B	AZAS100MUY				14.4	-	16	-	12	0.2	1	0.064	0.9
FVA100AMVEB	AZAS100MUY				14.8	-	16	-	12	0.2	1	0.238	1.2
FHA100AVEB9	AZAS100MUY				14.9	-	16	-	12	0.2	1	0.172	1.3
FCAG125BVEB	AZAS125MUY				14.6	-	16	-	12	0.2	1	0.168	1
FBA125A2VEB9	AZAS125MUY				15.1	-	16	-	12	0.2	1	0.187	1.5
FVA125AMVEB	AZAS125MUY				14.8	-	16	-	12	0.2	1	0.238	1.2
FHA125AVEB9	AZAS125MUY				15.1	-	16	-	12	0.2	1	0.217	1.5
FCAG140BVEB	AZAS140MUY				14.6	-	16	-	12	0.2	1	0.168	1
FBA140A2VEB9	AZAS140MUY				15.1	-	16	-	12	0.2	1	0.187	1.5
FVA140AMVEB	AZAS140MUY				15.0	-	16	-	12	0.2	1	0.276	1.4
FHA140AVEB9	AZAS140MUY				15.4	-	16	-	12	0.2	1	0.251	1.8
FVA140AMVEB	AZAS140MUV				27.5	-	32	-	24	0.2	1	0.276	1.4
FHA140AVEB9	AZAS140MUV				27.9	-	32	-	24	0.2	1	0.251	1.8
FHA35AVEB9	x3 RZASG100MUV				22.7	-	25	-	19	0.2	1	0.090 x3	0.6 x3
FHA50AVEB9	x2 RZASG100MUV				22.0	-	25	-	19	0.2	1	0.090 x2	0.6 x2
FHA100AVEB9	RZASG100MUV				22.2	-	25	-	19	0.2	1	0.172	1.3

4D148942



DETAILED TECHNICAL DRAWINGS

AZAS-MV/MY

Symbols			Notes
MCA	Minimum Circuit Ampere	[A]	1 The -RLA- is based on the following conditions. Cooling Indoor temperature -27.0°C DB / -19.0°C WB Outdoor temperature -35.0°C DB Heating Indoor temperature -20.0°C DB Outdoor temperature -7.0°C DB / -6.0°C WB 2 -TOCA- is the total value of each overcurrent set. 3 Voltage range The units are suitable for use with electrical systems in which the voltage supplied to the unit terminals is not below or above the listed range limits. 4 The maximum allowable voltage that is unbalanced between phases is -2%. 5 -MCA- is the maximum input current. The capacity of the -MFA- must be greater than that of the -MCA-. Select the -MFA- according to the table. 6 Select the wire size according to the MCA. 7 -MFA- is used to select the circuit breaker and the ground fault circuit interruptor. Earth leakage circuit breaker
TOCA	Total overcurrent amps	[A]	
MFA	Maximum Fuse Ampere	[A]	
MSC	Maximum current of the starting compressor	[A]	
RLA	Rated load amps	[A]	
OFM	Outdoor fan motor		
IFM	Indoor fan motor		
FLA	Full Load Ampere	[A]	
KW	Fan motor rated output	[kW]	

4D148942

AZAS-MV/MY

No.	Parts name	Remarks
1	Gas pipe connection	ø 15.9 flare
2	Liquid pipe connection	ø 9.5 flare
3	Service port	In the unit
4	Earth terminal	M4 (in control box)
5	Refrigerant piping intake	
6	Power supply wiring intake	ø 34 knock hole
7	Wiring between unit intake	ø 27 knock hole
8	Drain socket connection hole	i.d. ø 25 hose for connection
9	Drain port	ø 22 knock hole

Applicable model	Remarks
RZAC 85-100-125 CV1/CY1/C2V1/C2Y1, RZAV 71-85 CV1/CY1/C2V1/C2Y1, RZA71C2Y1, RZA 85-100-125C2V1/C2Y1, RZAS71-85C2V1, RXC71-85C2V1, RZAC36-48DVL, RZAC100DV12/RZAC140DY12	

3D121881D



AZAS-MV/MY

Installation servicing space (The unit of the values is mm.)

Installation of single unit

When nothing is obstructing the top

- (1) In case obstacles exist only in front of the air inlet. (2) In case obstacles exist in front of the air inlet and on both sides of the unit. (3) In case obstacles exist only in front of outlet side.

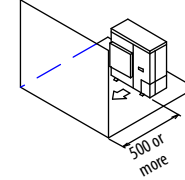
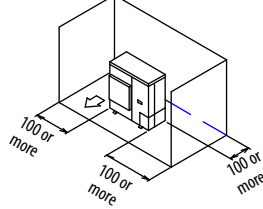
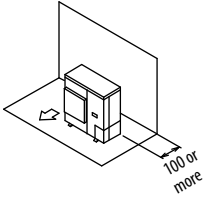

When something is obstructing the top

- (1) In case obstacles exist in front of the air inlet. (2) In case obstacles exist in front of the air inlet and on both sides of the unit. (3) In case obstacles exist in front of outlet side.

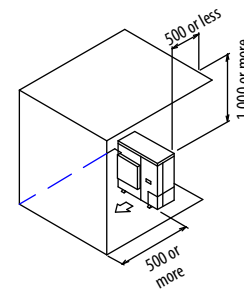
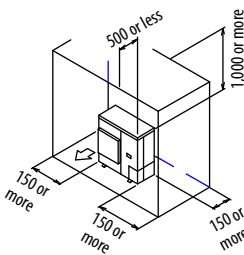
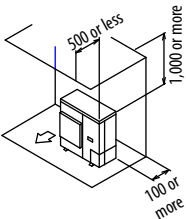

In case obstacles exist in front of both the air inlet and outlet sides

Pattern 1 Where obstacle in front of the air outlet is higher than the unit.

- (1) When nothing is obstructing the top. (2) When something is obstructing the top.
(There is no height limit for obstructions on the intake side.) Relation of dimensions of H, A, and L are shown in the table below

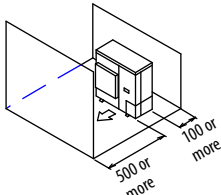

	L	A
$L \leq H$	$0 < L \leq 1/2H$	750 or more
	$1/2H < L \leq H$	1,000 or more
$L > H$	Set the frame to be $L \leq H$. Refer to the column of $L \leq H$ for A.	

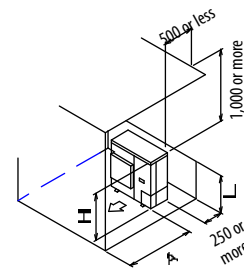

Pattern 2 Where obstacles in front of the air outlet is lower than the unit.

- (1) When nothing is obstructing the top. (2) When something is obstructing the top.
(There is no height limit for obstructions on the intake side.) Relation of dimensions of H, A, and L are shown in the table below

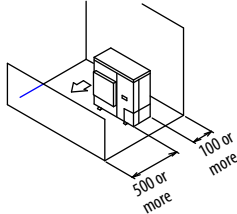

	L	A
$L \leq H$	$0 < L \leq 1/2H$	100 or more
	$1/2H < L \leq H$	200 or more
$L > H$	Set the frame to be $L \leq H$. Refer to the column of $L \leq H$ for A.	

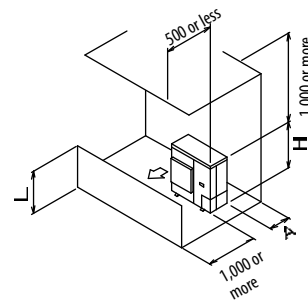

Get the lower part of the frame sealed so that air from the outlet does not bypass.

IN CASE OF INSTALLING MULTIPLE UNITS (2 UNITS OR MORE) IN LATERAL CONNECTION PER ROW

- Secure appropriate space when using a side piping outlet.

When nothing is obstructing the top

- (1) In case obstacles exist in front of the air inlet and on both sides of the unit. (2) In case obstacles exist only in front of outlet side.

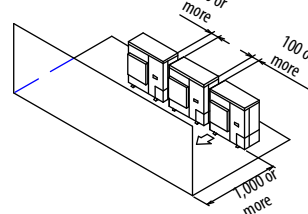
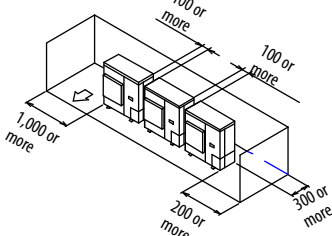

AZAS-MV/MY

When something is obstructing the top

(1) In case obstacles exist in front of outlet side.

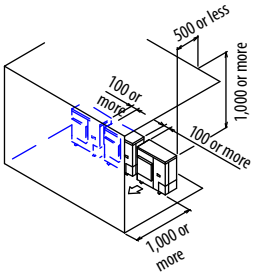

(2) In case obstacles exist in front of the air inlet and on both sides of the unit.

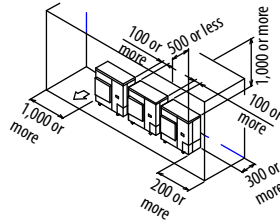

In case obstacles exist in front of both the air inlet and outlet sides

Pattern 1 Where obstacle in front of the air outlet is higher than the unit.

(1) When nothing is obstructing the top.
(There is no height limit for obstructions on the intake side.)

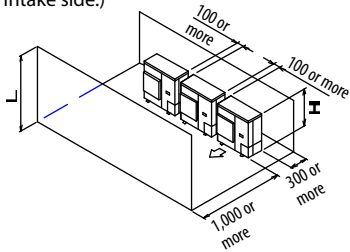

(2) When something is obstructing the top.
Relation of dimensions of H, A, and L are shown in the table below

	L	A
$L \leq H$	$0 < L \leq 1/2H$	1,000 or more
	$1/2H < L \leq H$	1,250 or more
$L > H$	Set the frame to be $L \leq H$. Refer to the column of $L \leq H$ for A.	

Get the lower part of the frame sealed so that air from the outlet does not bypass.
Only two units at most can be installed in series

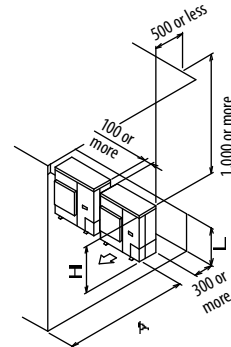

Pattern 2 Where obstacles in front of the air outlet is lower than the unit.

(1) When nothing is obstructing the top.
(There is no height limit for obstructions on the intake side.)

L	A
$0 < L \leq 1/2H$	250 or more
$1/2H < L \leq H$	300 or more

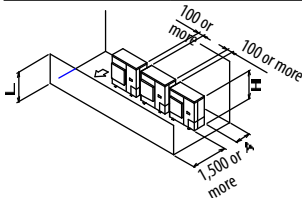

(2) When something is obstructing the top.
Relation of dimensions of H, A, and L are shown in the table below

	L	A
$L \leq H$	$0 < L \leq 1/2H$	250 or more
	$1/2H < L \leq H$	300 or more
$L > H$	Set the frame to be $L \leq H$. Refer to the column of $L \leq H$ for A.	

Get the lower part of the frame sealed so that air from the outlet does not bypass.
Only two units at most can be installed in series.

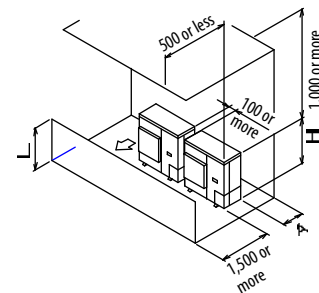

IN CASE OF STACKED INSTALLATION

(1) In case obstacles exist in front of outlet side.

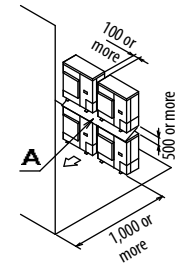

(2) In case obstacles exist in front of the air inlet.

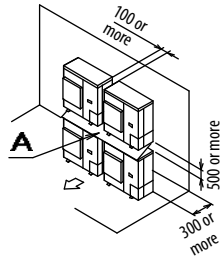

- Do not exceed two levels for stacked installation.
- Install a roof cover similar to A (field supply), as outdoor units with downward drainage are prone to dripping and freezing.
- Install the upper-level outdoor unit so that its bottom plate is a sufficient height above the roof cover. This is to prevent the buildup of ice on the underside of the bottom plate. (A space of at least 500 mm is recommended.)
- It is not necessary to install a roof cover if there is no danger of drainage dripping and freezing. In this case, the space between the upper and lower outdoor units should be at least 100 mm. (Close off the gap between the upper and lower units so there is no re-intake of discharged air.)

IN CASE OF MULTIPLE-ROW INSTALLATION (FOR ROOF TOP USE, ETC.)

(1) In case of installing one unit per row.

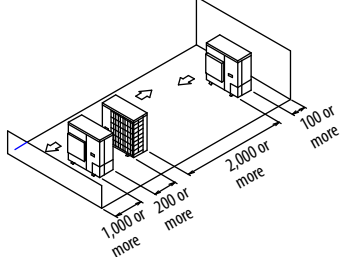

(2) When something is obstructing the top.

Relation of dimensions of H, A, and L are shown in the table below

	L	A
$L \leq H$	$0 < L \leq 1/2H$	250 or more
	$1/2H < L \leq H$	300 or more
$L > H$	Installation impossible	

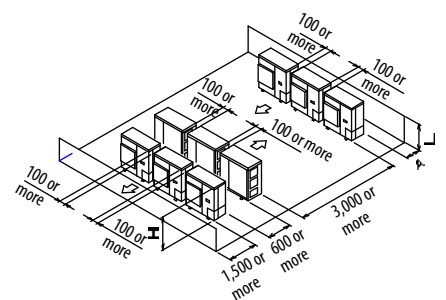



AZAS-MV/MY

To determine the complete recharge amount (kg)

Model	Lenght
	5~30m
AZAS71	2.45 Kg
AZAS100- 125	2.6 Kg
AZAS140	2.9 Kg

4PEN485929-1D_2019_04



RXM-R9 / ARXM-R9

Unit combination restrictions				Power supply		Compressor		OFM		IFM		
Outdoor unit	Indoor unit	Hz	Voltage	Voltage range	MCA	MFA	RHz	RLA	kW	FLA	kW	FLA
ARXM50R2V1B	ADEA50A2VEB	50	220	Maximum -50-Hz -264-V	15.42	16	55	5.2	0.06	0.37	0.089	1.40
		50	230					5.0				
		50	240					4.8				
ARXM60R2V1B	ADEA60A2VEB	50	220	Maximum -50-Hz -264-V	15.86	16	66	6.2	0.06	0.37	0.070	1.30
		50	230					6.0				
		50	240					5.7				
ARXM71R2V1B	ADEA71A2VEB	50	220	Maximum -50-Hz -264-V	15.83	16	81	8.2	0.06	0.37	0.070	1.30
		50	230					7.8				
		50	240					7.5				
ARXM71R2V1B	FCAG71BVEB	50	220	Maximum -50-Hz -264-V	14.93	16	81	8.1	0.06	0.37	0.054	0.40
		50	230					7.7				
		50	240					7.4				
ARXM71R2V1B	FBA71A2VEB9	50	220	Maximum -50-Hz -264-V	15.83	16	81	8.2	0.06	0.37	0.070	1.30
		50	230					7.8				
		50	240					7.5				
ARXM71R2V1B	FAA71BUV1B	50	220	Maximum -50-Hz -264-V	14.93	16	83	8.3	0.06	0.37	0.048	0.40
		50	230					7.9				
		50	240					7.6				
RXM42R2V1B	FTXM42R2V1B	50	220	Maximum -50-Hz -264-V	10.36	16	48	4.3	0.06	0.37	0.034	0.30
		50	230					4.1				
		50	240					4.0				
RXM42R2V1B	FTXM42R5V1B	50	220	Maximum -50-Hz -264-V	10.36	13	48	4.3	0.06	0.37	0.034	0.30
		50	230					4.1				
		50	240					4.0				
RXM50R2V1B	FTXM50R2V1B	50	220	Maximum -50-Hz -264-V	14.54	13	54	4.7	0.06	0.37	0.046	0.60
		50	230					4.5				
		50	240					4.3				
ARXM50R2V1B	ATXM50R2V1B	50	220	Maximum -50-Hz -264-V	14.54	16	54	4.7	0.06	0.37	0.046	0.60
		50	230					4.5				
		50	240					4.3				
RXM50R2V1B	FCAG50BVEB	50	220	Maximum -50-Hz -264-V	14.21	16	58	5.2	0.06	0.37	0.048	0.30
		50	230					5.0				
		50	240					4.8				
RXM50R2V1B	FBA50A2VEB9	50	220	Maximum -50-Hz -264-V	15.42	16	55	5.2	0.06	0.37	0.089	1.40
		50	230					5.0				
		50	240					4.8				
RXM50R2V1B	FHA50AVEB99	50	220	Maximum -50-Hz -264-V	14.54	16	64	5.5	0.06	0.37	0.090	0.60
		50	230					5.3				
		50	240					5.2				
RXM50R2V1B	FFA50A2VEB9	50	220	Maximum -50-Hz -264-V	14.32	16	62	5.6	0.06	0.37	0.050	0.40
		50	230					5.4				
		50	240					5.3				
RXM50R2V1B	FDXM50F3V1B9	50	220	Maximum -50-Hz -264-V	14.87	16	55	4.9	0.06	0.37	0.060	0.90
		50	230					4.7				
		50	240					4.5				
RXM50R2V1B	FNA50A2VEB9	50	220	Maximum -50-Hz -264-V	14.43	16	55	4.9	0.06	0.37	0.060	0.50
		50	230					4.7				
		50	240					4.5				
RXM50R2V1B	FVXM50FV1B9	50	220	Maximum -50-Hz -264-V	14.32	16	60	5.4	0.06	0.37	0.048	0.10
		50	230					5.2				
		50	240					5.0				
RXM60R2V1B	FTXM60R2V1B	50	220	Maximum -50-Hz -264-V	15.09	16	70	6.6	0.06	0.37	0.046	0.60
		50	230					6.3				
		50	240					6.0				
RXM60R2V1B	FCAG60BVEB	50	220	Maximum -50-Hz -264-V	14.76	16	71	6.5	0.06	0.37	0.048	0.30
		50	230					6.3				
		50	240					6.2				
RXM60R2V1B	FBA60A2VEB9	50	220	Maximum -50-Hz -264-V	15.86	16	66	6.1	0.06	0.37	0.070	1.30
		50	230					6.0				
		50	240					5.8				
RXM60R2V1B	FHA60AVEB99	50	220	Maximum -50-Hz -264-V	15.09	16	62	5.5	0.06	0.37	0.091	0.60
		50	230					5.3				
		50	240					5.1				
RXM60R2V1B	FFA60A2VEB9	50	220	Maximum -50-Hz -264-V	15.09	16	70	6.5	0.06	0.37	0.050	0.60
		50	230					6.3				
		50	240					6.2				
RXM60R2V1B	FDXM60F3V1B9	50	220	Maximum -50-Hz -264-V	15.42	16	73	6.7	0.06	0.37	0.060	0.90
		50	230					6.5				
		50	240					6.4				
RXM60R2V1B	FNA60A2VEB9	50	220	Maximum -50-Hz -264-V	15.09	16	73	6.7	0.06	0.37	0.060	0.60
		50	230					6.5				
		50	240					6.4				
RXM71R2V1B	FTXM71R2V1B	50	220	Maximum -50-Hz -264-V	19.78	20	54	9.4	0.13	0.38	0.052	0.60
		50	230					8.9				
		50	240					8.6				

Symbols			Notes	
MCA	Minimum Circuit Ampere	[A]	1 The RLA is based on the following conditions. Outdoor temperature 35°C DB Indoor temperature 27°C DB / 19°C WB 2 Select the wire size according to the MCA. 3 The maximum allowable voltage that is unbalanced between phases is 2%. 4 Use a circuit breaker instead of a fuse.	
MFA	Maximum Fuse Ampere	[A]		
RLA	Rated load amps	[A]		
OFM	Outdoor fan motor			
IFM	Indoor fan motor			
FLA	Full Load Ampere	[A]		
kW	Fan motor rated output	[kW]		
RHz	Rated operating frequency	[Hz]		

4D131055B



ARXM71R9

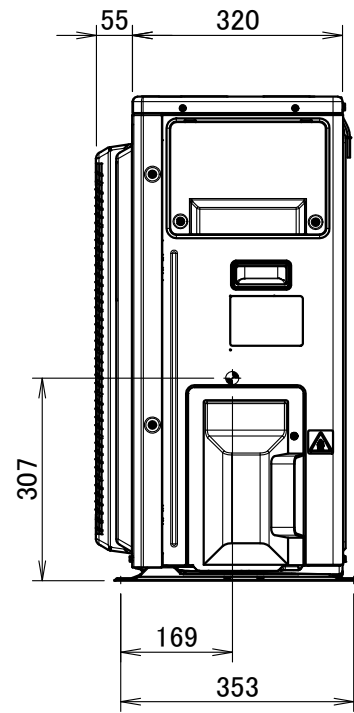
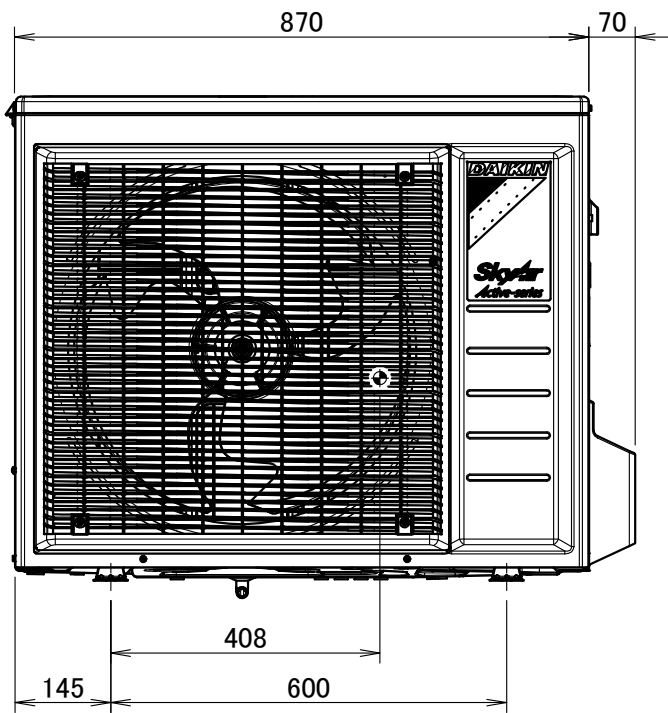

4D120417



Technical drawings **Biddle air curtains**

CYA-DK-F/C/R

235



CYA-DK-F

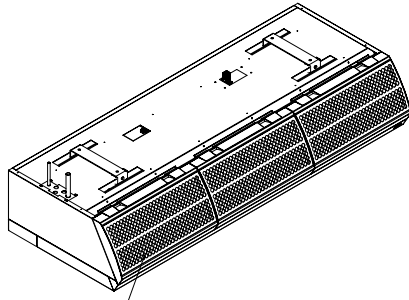

Suction grid
with filter

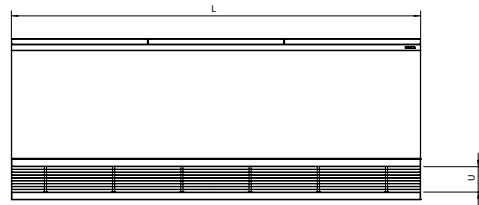
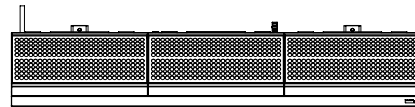
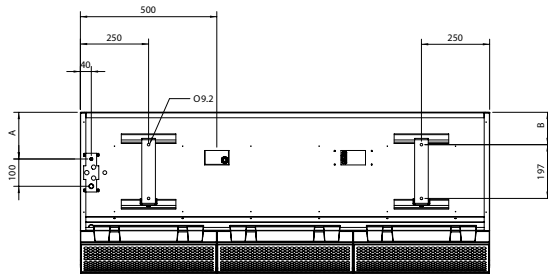
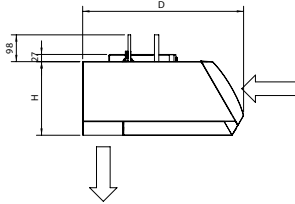

Type	L	H	D	U	A	B
Small	1,000 - 1,500	270	590	93	171	119
Medium	2,000 - 2,500					
Large	1,000 - 1,500	370	774	124.5	245.5	200
	2,000 - 2,500					

NOTES

1. The 2,500mm large devices have 3 suspension brackets, where the third bracket is mounted at half the length of the device.

CU0954X-000

CYA-DK-C

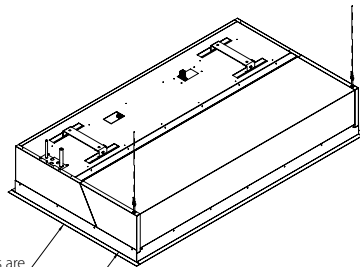

The finishing profiles are
supplied separately.

Suction grid
with filter

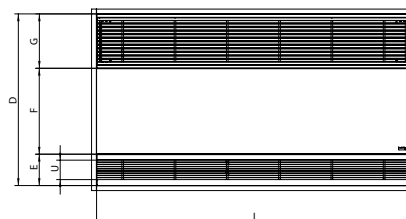
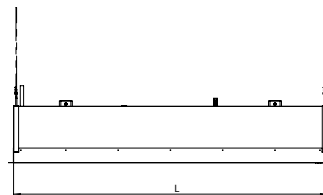
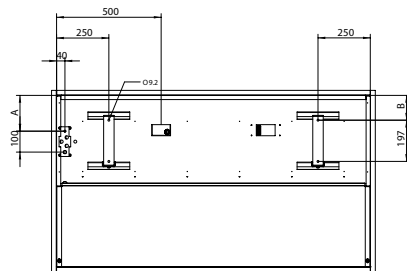
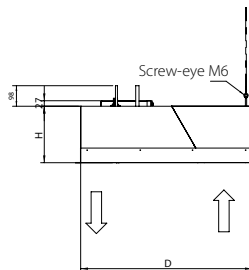

Number of suction grids per device

Device length	Number	Suction grid length
1,000 / 1,500	1	1,000 / 1,500
2,000 / 2,500	2	1,000 / 1,250

*1 drain grid per device

Type	L	H	D	U	A	B	E	F	G
Small	1,000 - 1,500	270	821	93	171	119	250	411	260
Medium	2,000 - 2,500								
Large	1,000 - 1,500	370	1,105	124.5	245.5	200	181.5	563.5	360
	2,000 - 2,500								

NOTES

1. The 2,500mm large devices have 3 suspension brackets, where the third bracket is mounted at half the length of the device.
2. The mounting holes for finishing profiles in a lowered ceiling (L+8) x (D+8) mm

CU0955X-000



CYA-DK-R

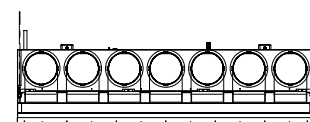
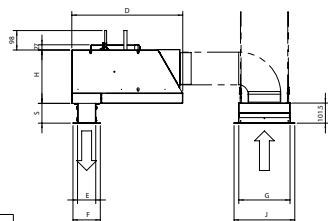
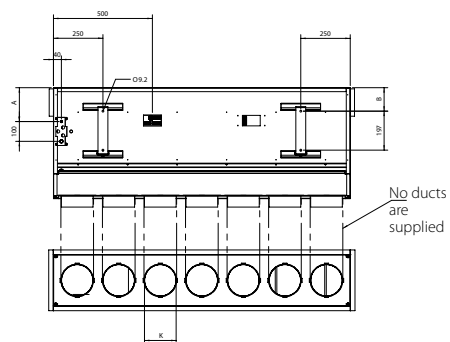
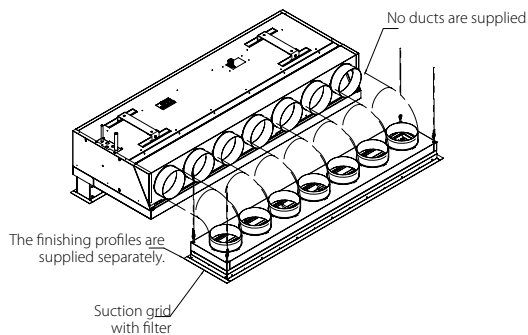

Number of ducts per device

Type	1,000	1,500	2,000	2,500
Small	5	7	10	12
Medium				
Large	3	5	6	8

Number of suction grids per device

Device length	Number	Suction grid length
1,000 / 1,500	1	1,000 / 1,500
2,000 / 2,500	2	1,000 / 1,250

*1 drain grid per device

Type	L	H	D	S	U	A	B	E	F	G	J	K	M	T
CYVS-DK-RBN/RSN	1,000 - 1,500	270	561	80-125	90	171	119	92	139	260	308	Ø160	1,044-1,544	1,048-1,548
CYVM-DK-RBN/RSN	2,000 - 2,500												2,044-2,544	2,048-2,548
CYVL-DK-RBN/RSN	1,000 - 1,500	370	745	80-125	121.5	245.5	200	123.5	170	360	408	Ø250	1,044-1,544	1,048-1,548
	2,000 - 2,500												2,044-2,544	2,048-2,548

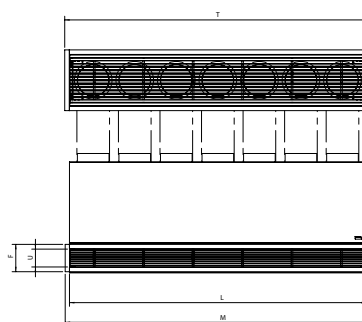

NOTES

- The 2,500mm large devices have 3 suspension brackets, where the third bracket is mounted at half the length of the device.
- Holes (for finishing profiles) - drain (L+8) x (E+8) mm - suction (L+8) x (G+8) mm.

CU0956X-000



Technical drawings

Ventilation

ALB-LBS/RBS	238
VAM-FC / VAM-J	244
EKVDX-A	252



DETAILED TECHNICAL DRAWINGS

ALB02RBS/LBS

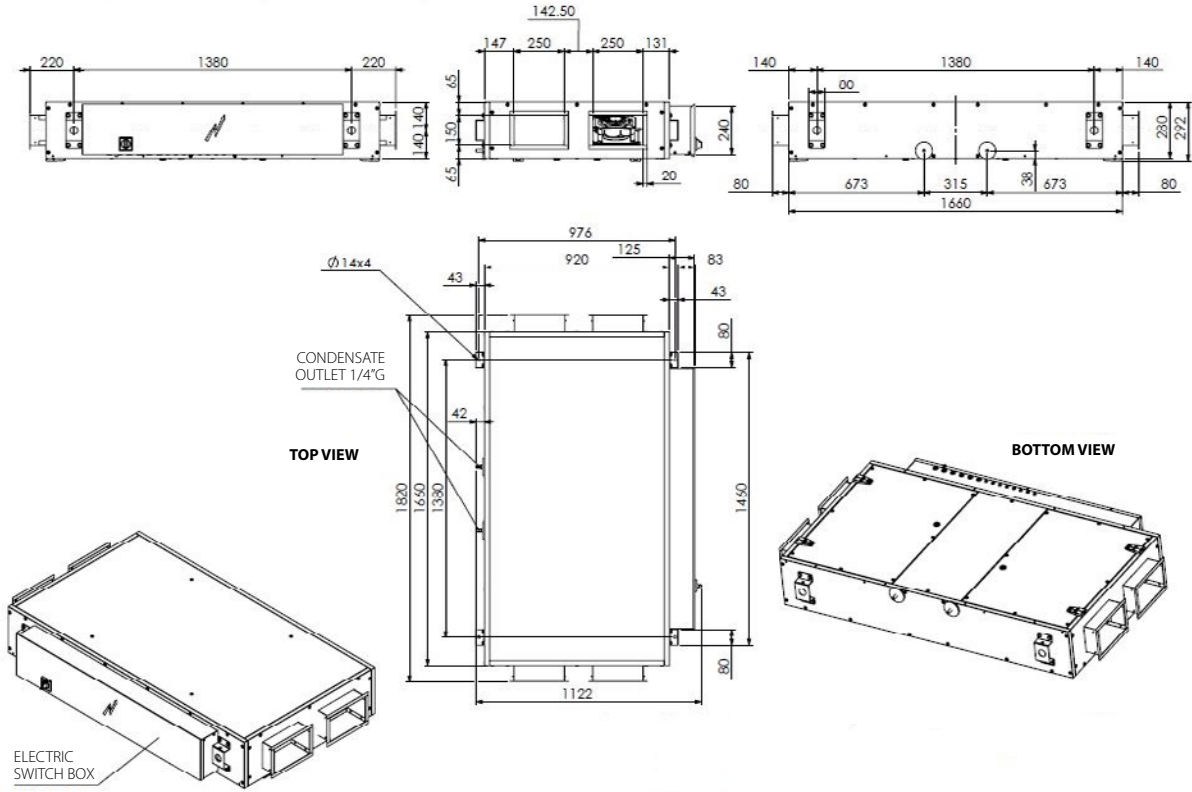

ALB03RBS/LBS

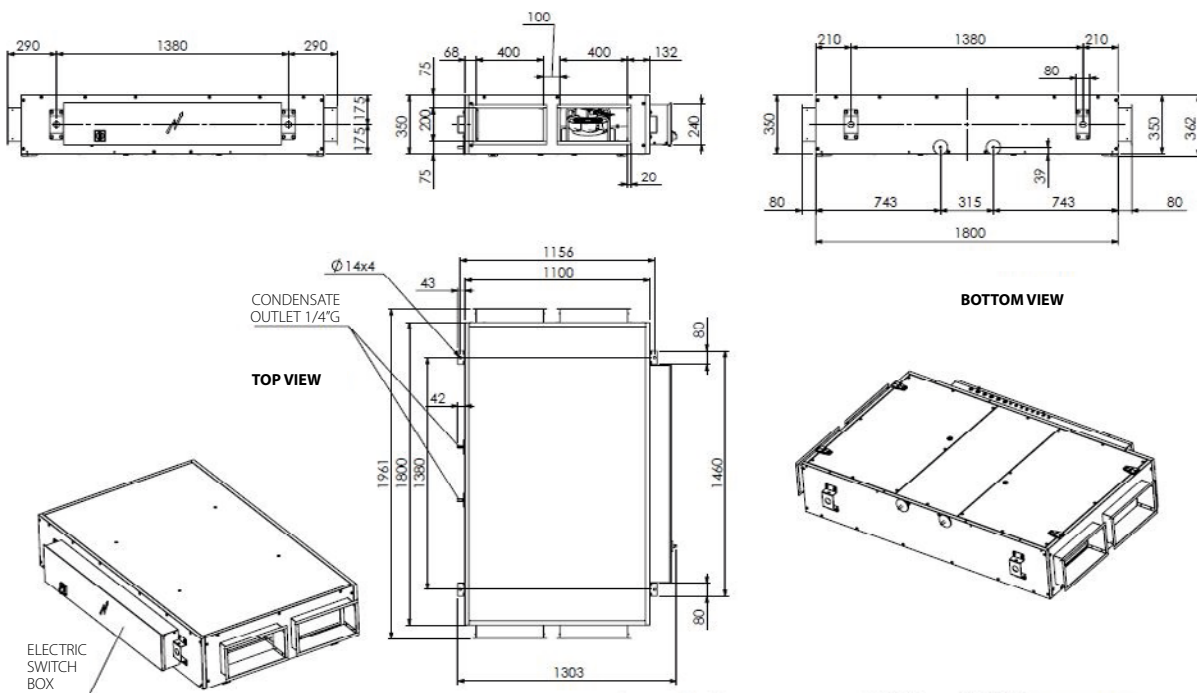



ALB04RBS/LBS

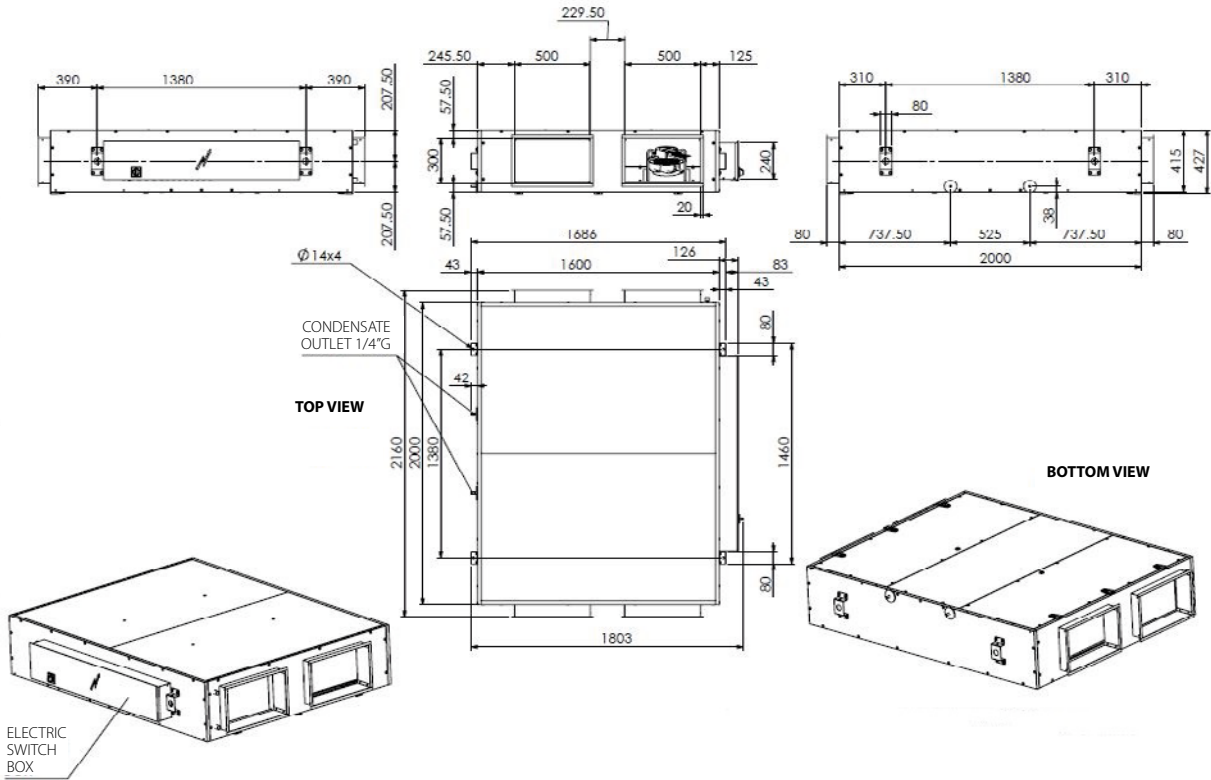

ALB05RBS/LBS

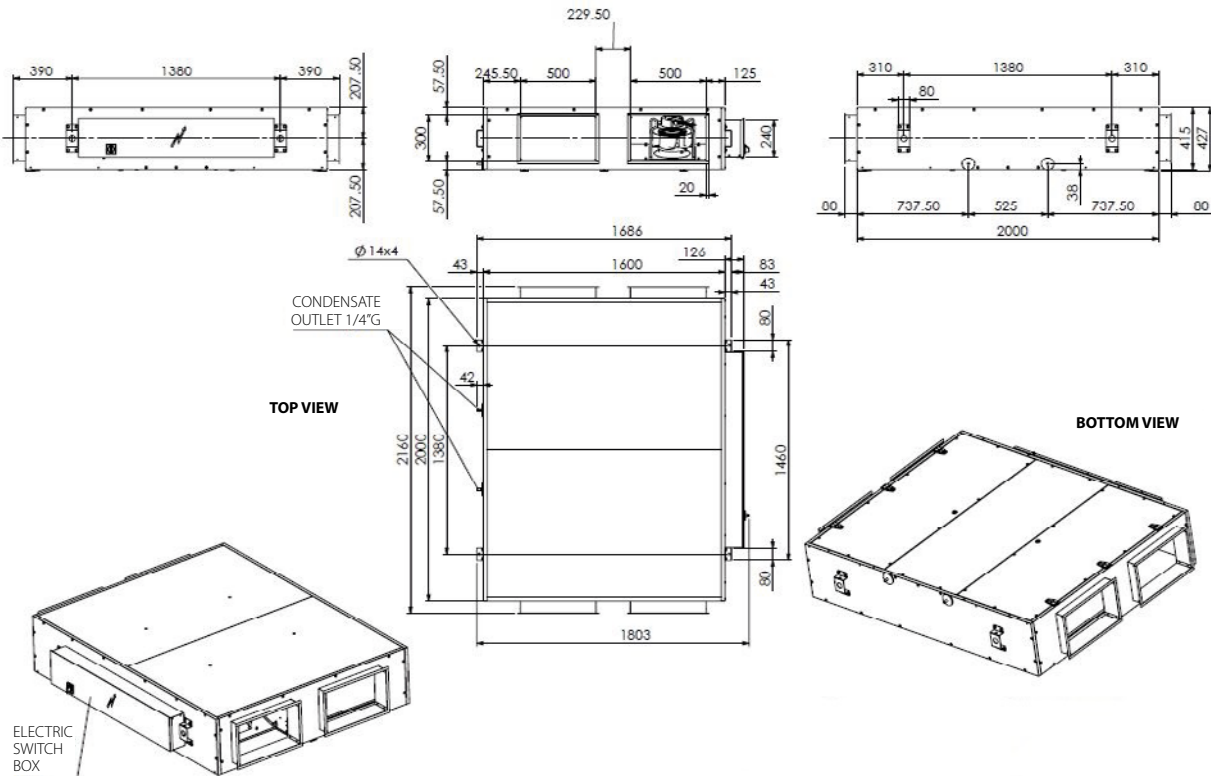

DETAILED TECHNICAL DRAWINGS

ALB06RBS/LBS

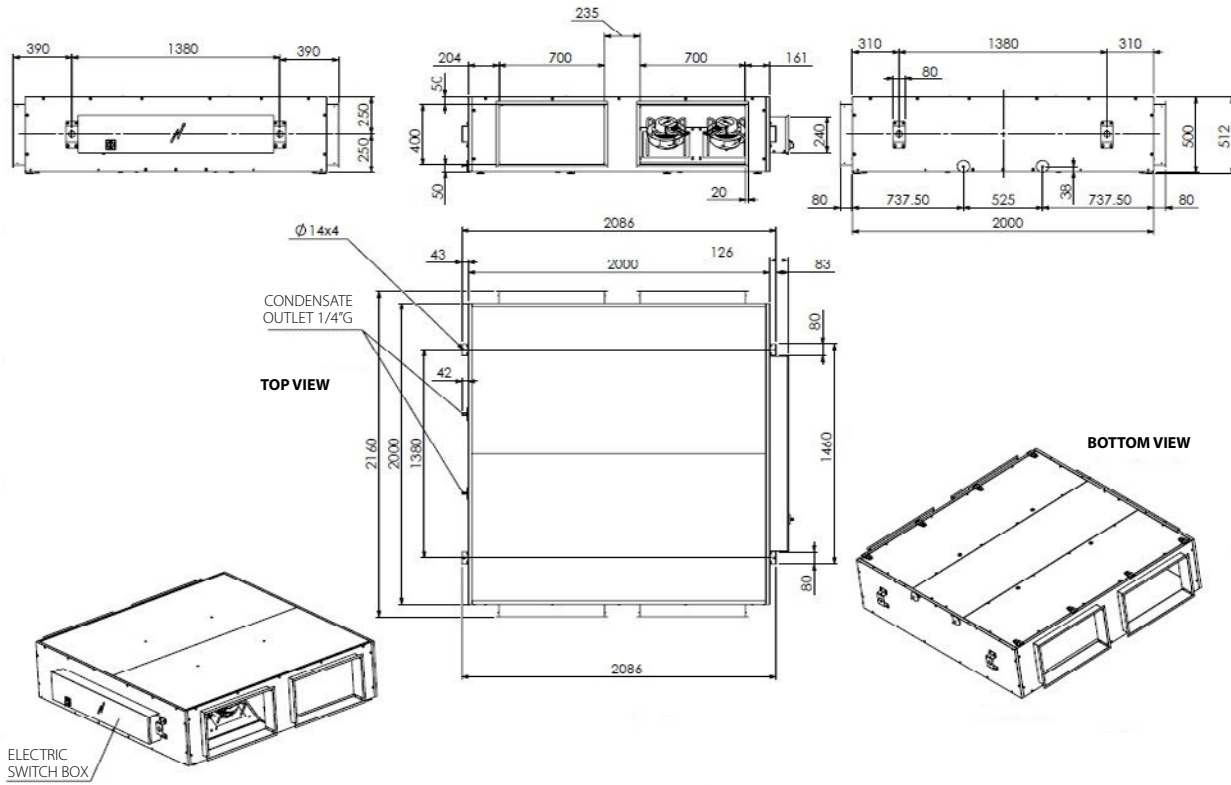

ALB07RBS/LBS

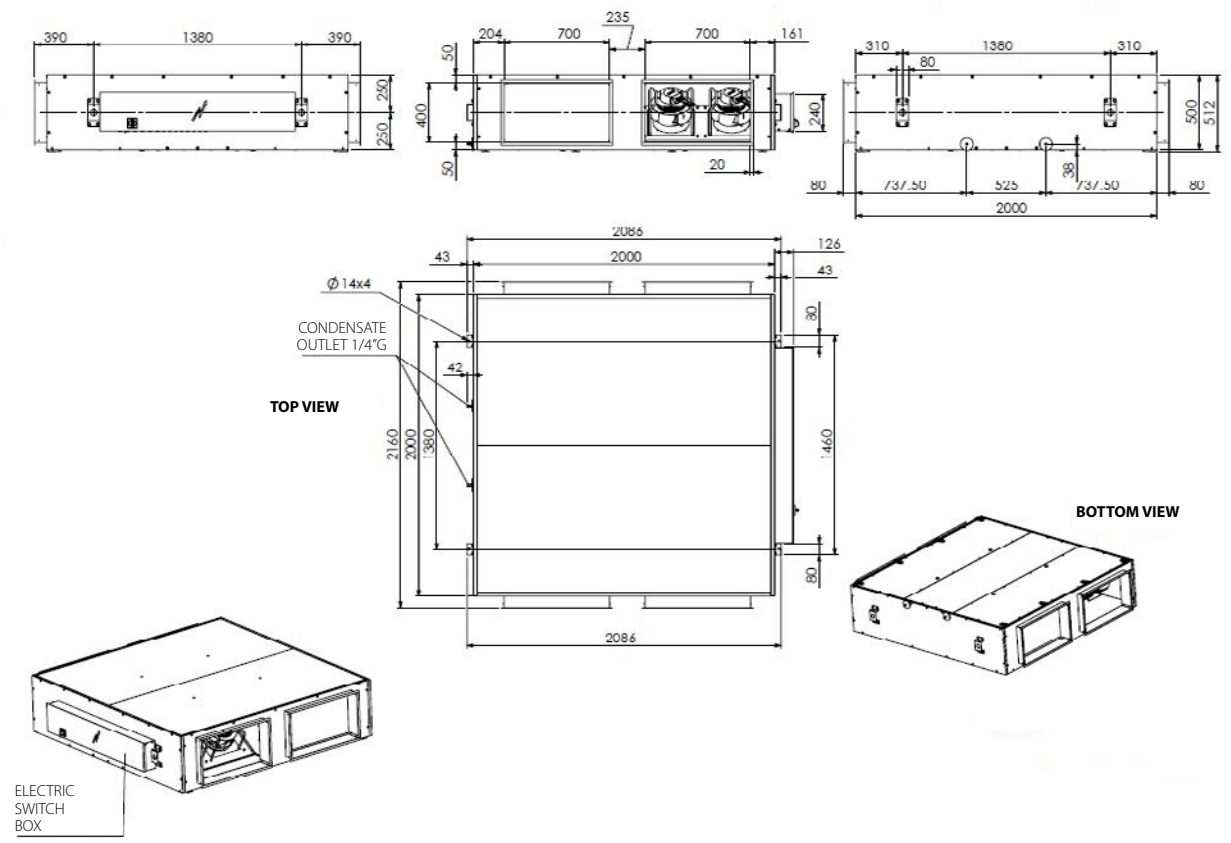



ALB02RBS/LBS

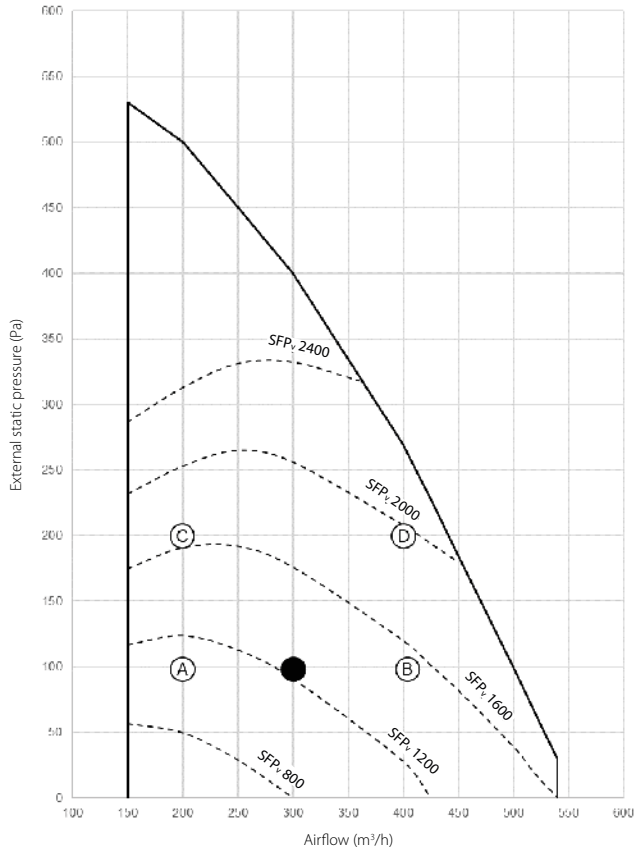

The diagram shows the available external pressure for the duct system given an airflow.

SFPv = Specific Fan Power (W/m³/s)

The SFPv curves are referring to the complete unit. Moreover, it includes power to both supply and extract fan divided by either the supply or extract volume whichever is the greater.

● Nominal working point

ALB03RBS/LBS

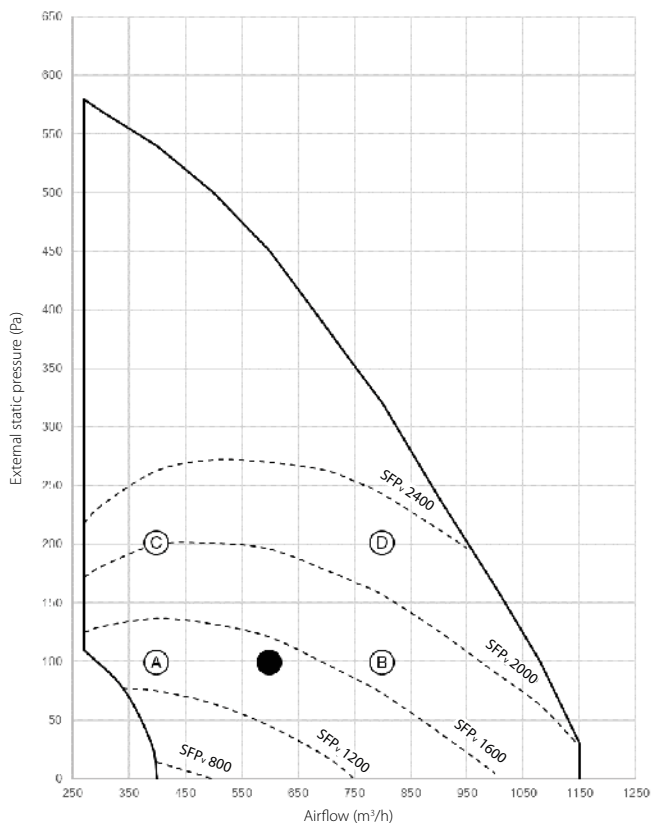

The diagram shows the available external pressure for the duct system given an airflow.

SFPv = Specific Fan Power (W/m³/s)

The SFPv curves are referring to the complete unit. Moreover, it includes power to both supply and extract fan divided by either the supply or extract volume whichever is the greater.

● Nominal working point



ALB04RBS/LBS

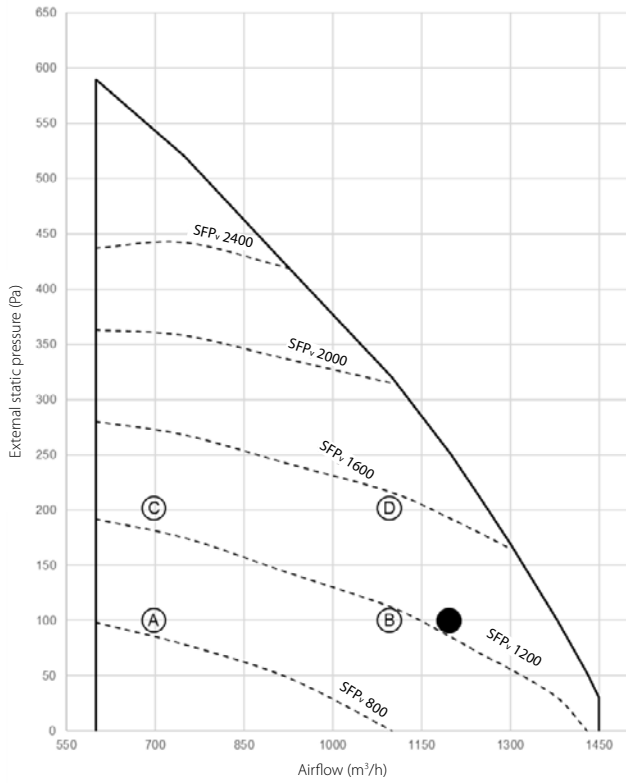

The diagram shows the available external pressure for the duct system given an airflow.

SFPv = Specific Fan Power (W/m³/s)

The SFPv curves are referring to the complete unit. Moreover, it includes power to both supply and extract fan divided by either the supply or extract volume whichever is the greater.

● Nominal working point

ALB05RBS/LBS

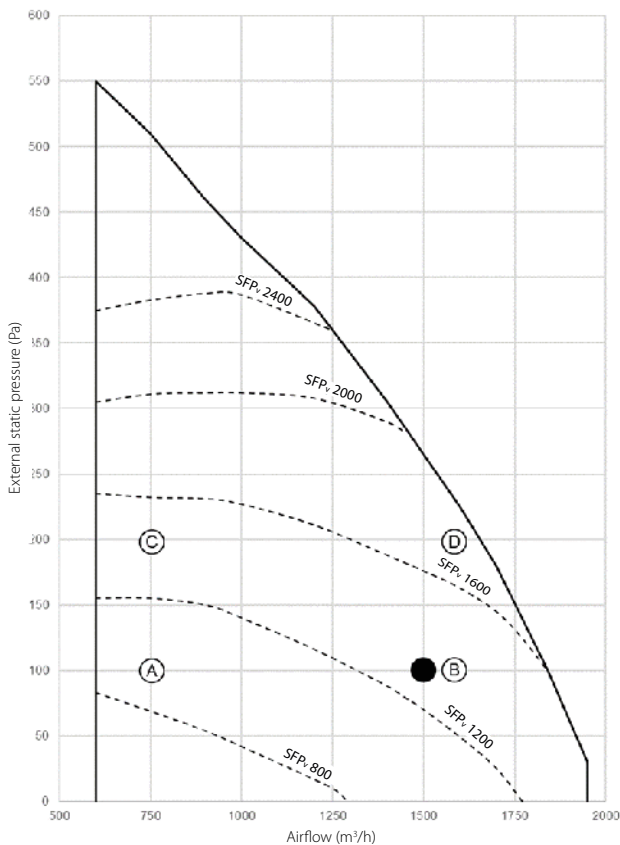

The diagram shows the available external pressure for the duct system given an airflow.

SFPv = Specific Fan Power (W/m³/s)

The SFPv curves are referring to the complete unit. Moreover, it includes power to both supply and extract fan divided by either the supply or extract volume whichever is the greater.

● Nominal working point



ALB06RBS/LBS

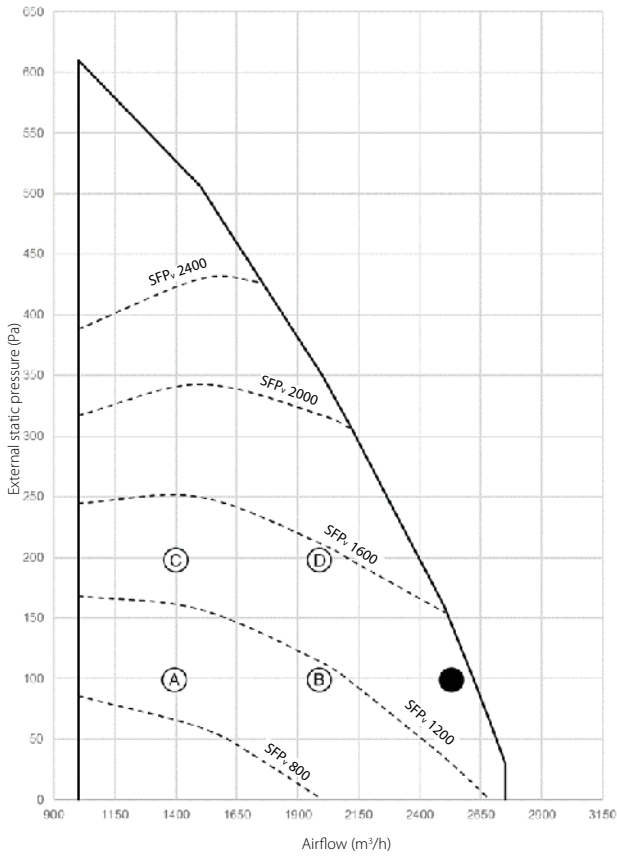

The diagram shows the available external pressure for the duct system given an airflow.

SFPv = Specific Fan Power (W/m³/s)

The SFPv curves are referring to the complete unit. Moreover, it includes power to both supply and extract fan divided by either the supply or extract volume whichever is the greater.

● Nominal working point

ALB07RBS/LBS

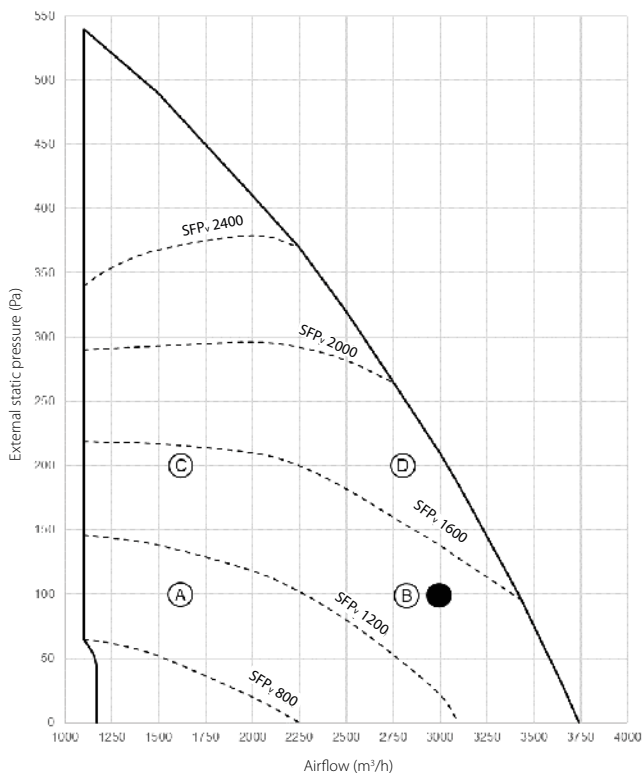

The diagram shows the available external pressure for the duct system given an airflow.

SFPv = Specific Fan Power (W/m³/s)

The SFPv curves are referring to the complete unit. Moreover, it includes power to both supply and extract fan divided by either the supply or extract volume whichever is the greater.

● Nominal working point

DETAILED TECHNICAL DRAWINGS

VAM150FC9

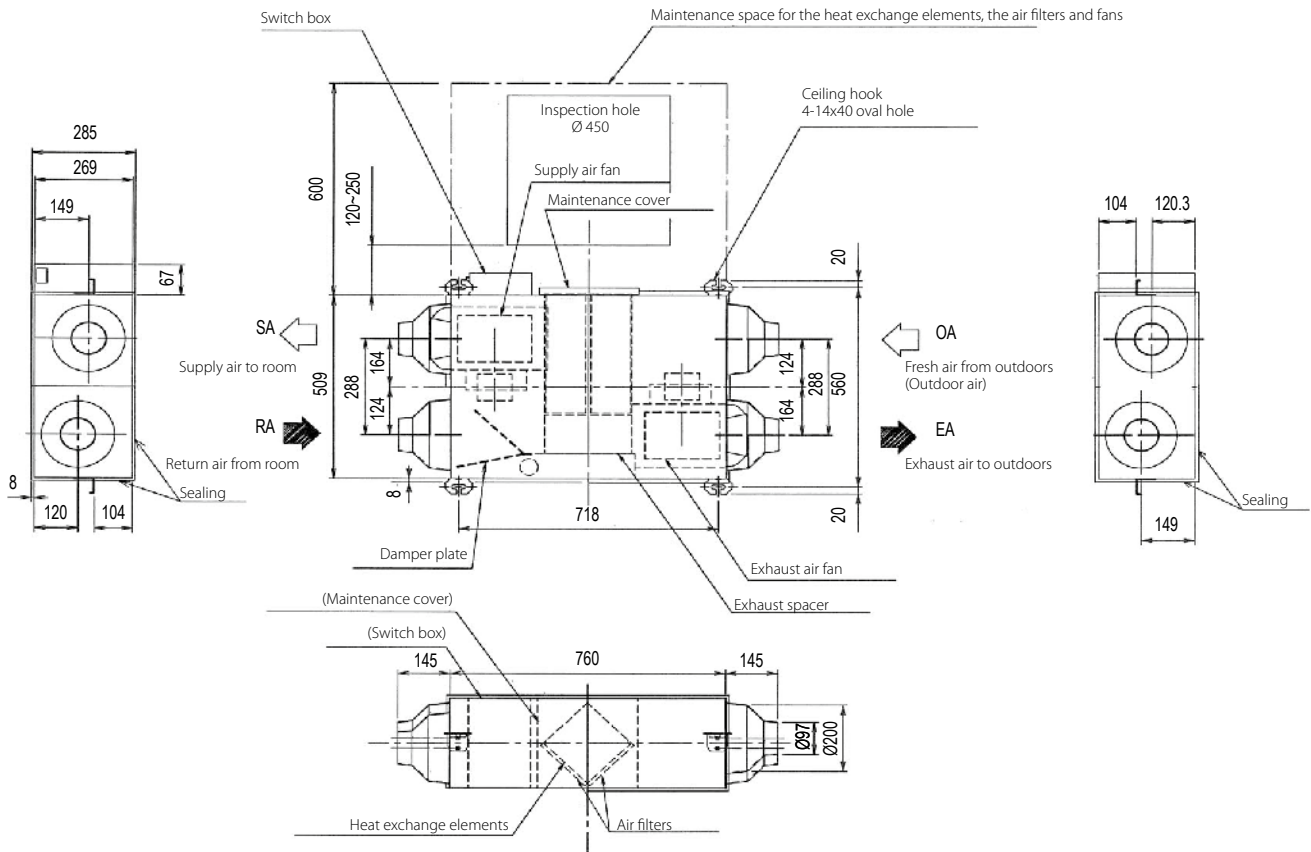

NOTES

1. Be sure to provide the inspection hole (450x450 mm) to inspect the air filters, the exchange elements and fans.

3TW27874-1

VAM250FC9

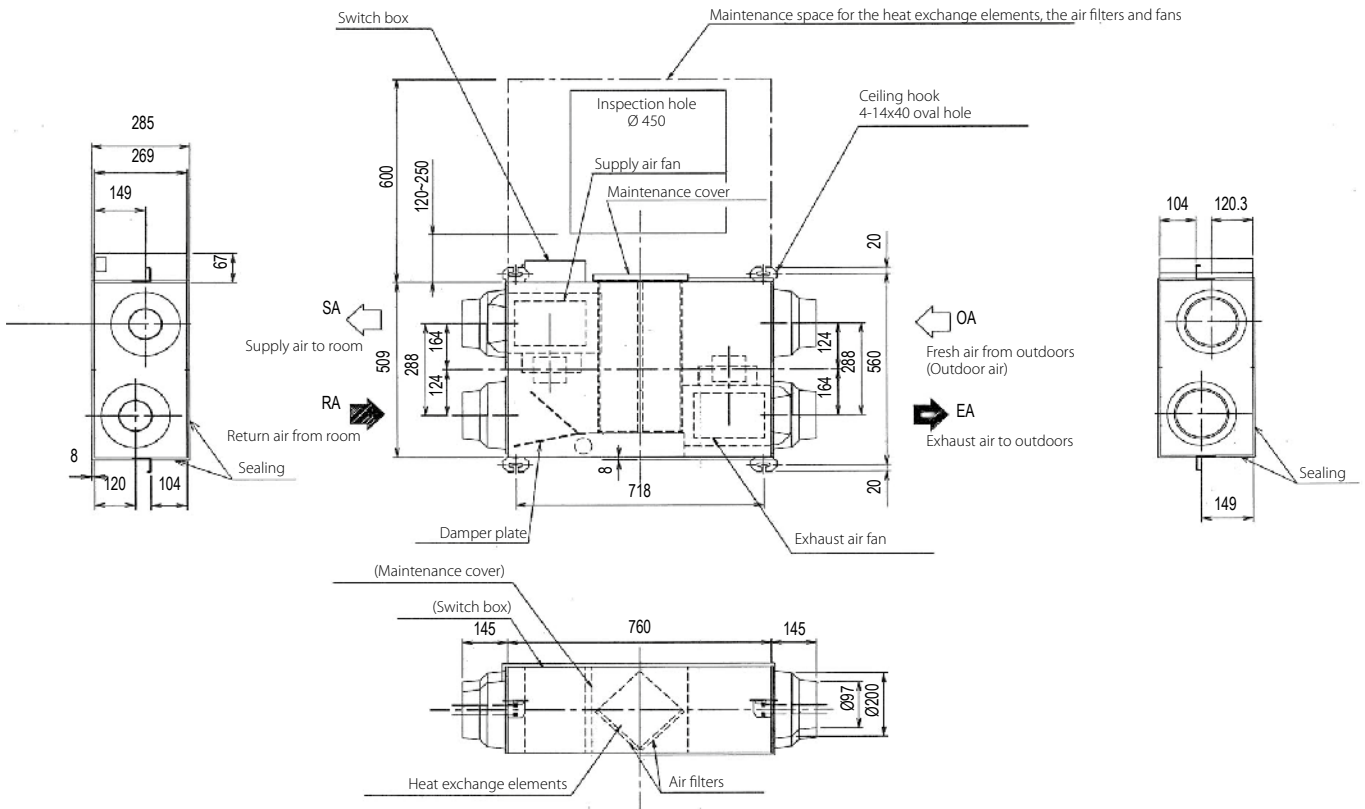

NOTES

1. Be sure to provide the inspection hole (450x450 mm) to inspect the air filters, the exchange elements and fans.

3TW27884-1



VAM350-500J

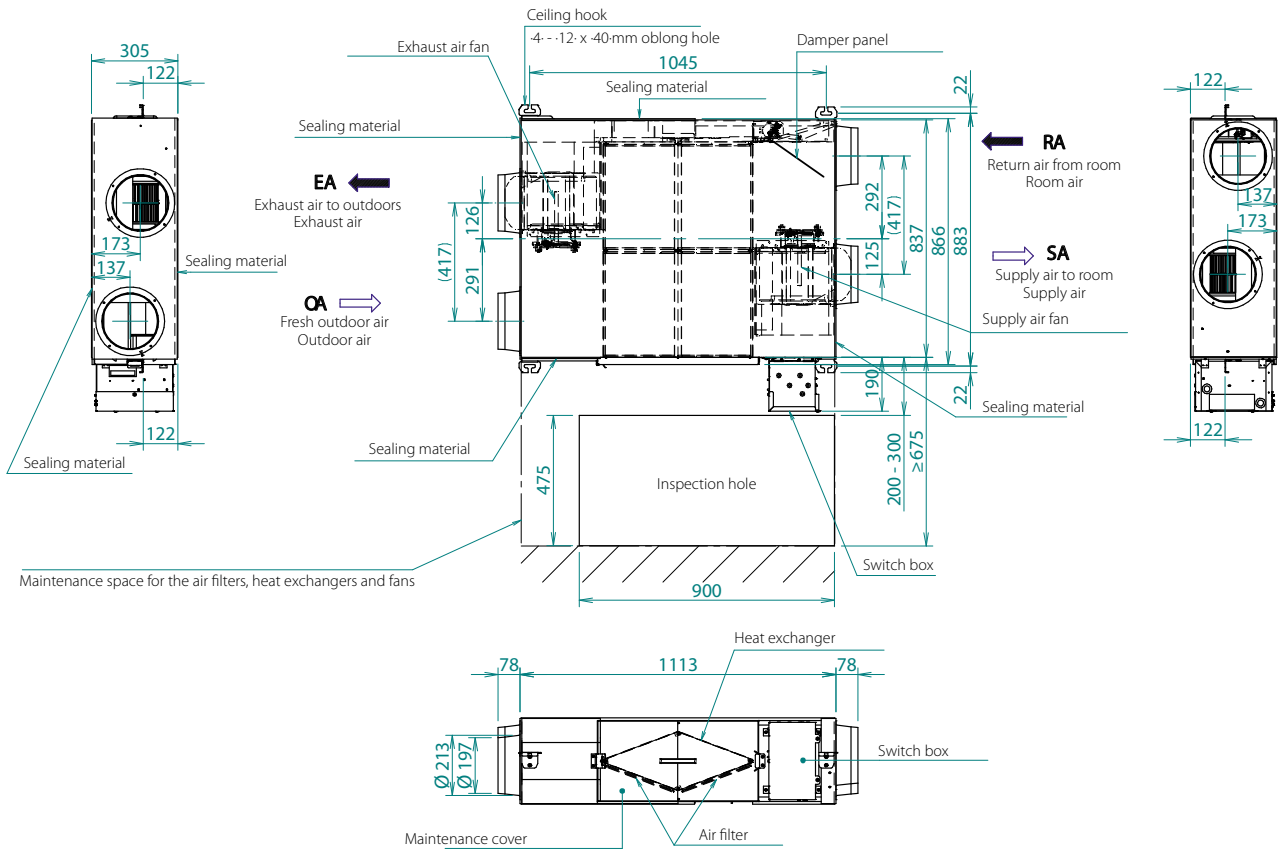

NOTES

1. To allow for the inspection of the air filters, heat exchangers, and fans, be sure to provide the inspection hole.

3D112815C

VAM650J

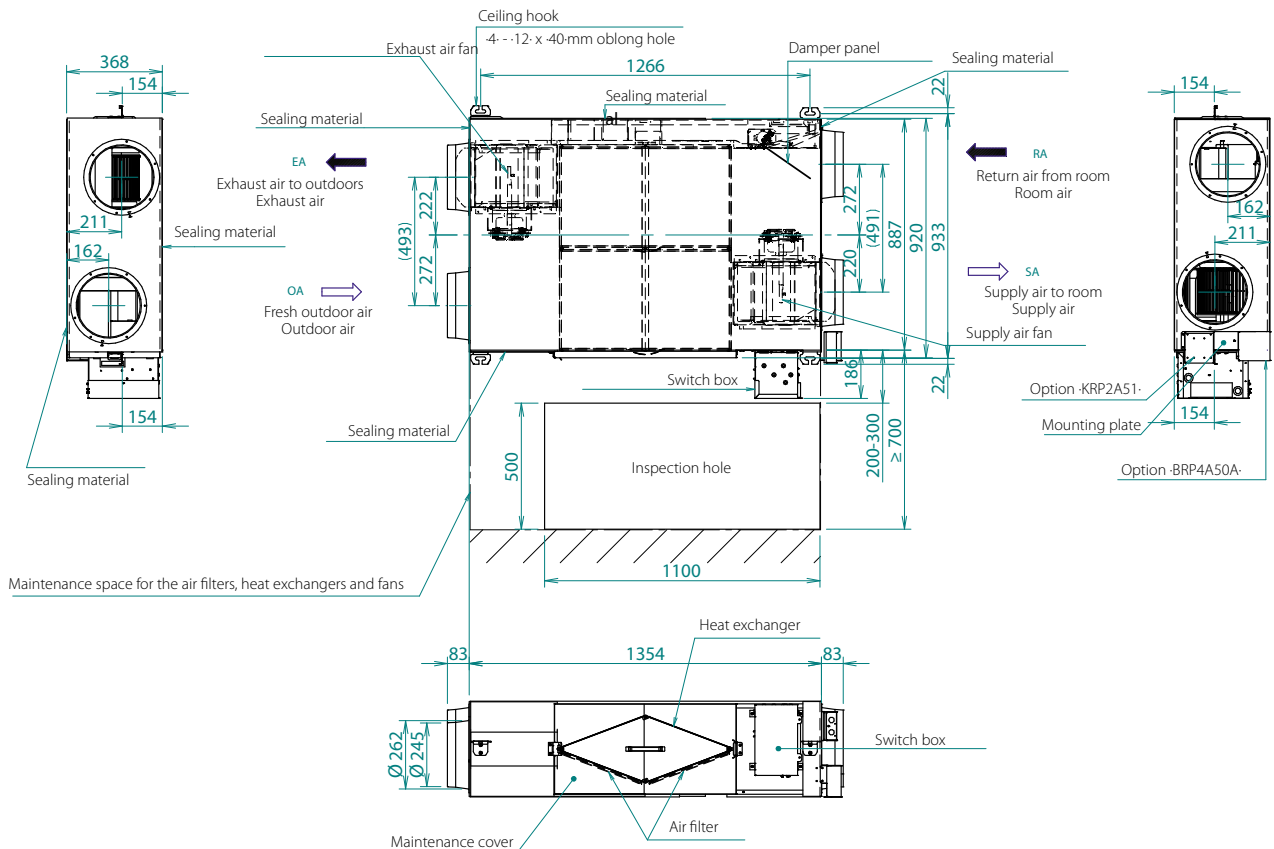

NOTES

1. To allow for the inspection of the air filters, heat exchangers, and fans, be sure to provide the inspection hole.

3D113502A

DETAILED TECHNICAL DRAWINGS

VAM800-1000J

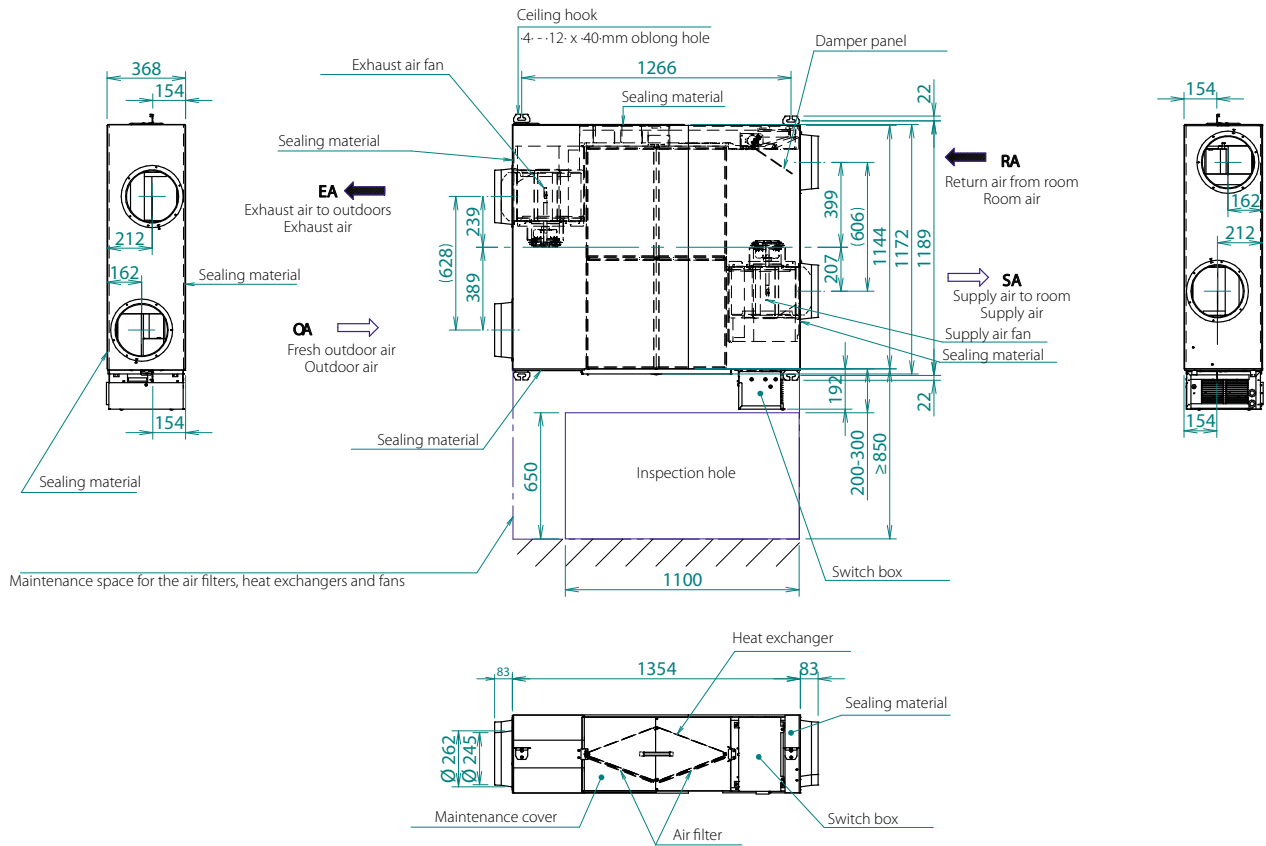

NOTES

1. To perform maintenance on the air filter, it is required to provide a service access panel.

3D112817D

VAM1500-2000J

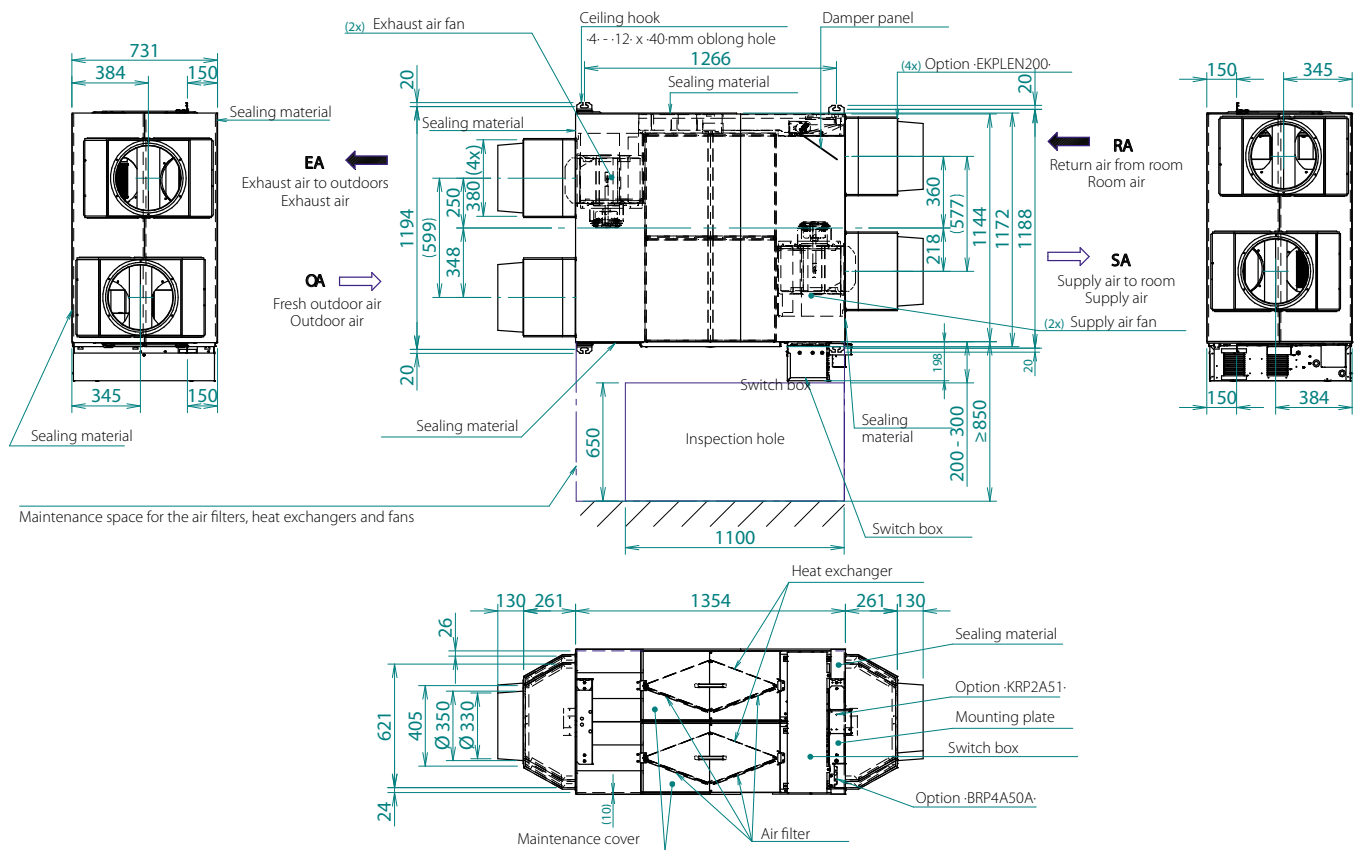

NOTES

1. To allow for the inspection of the air filters, heat exchangers, and fans, be sure to provide the inspection hole.

3D112818C



VAM150FC9

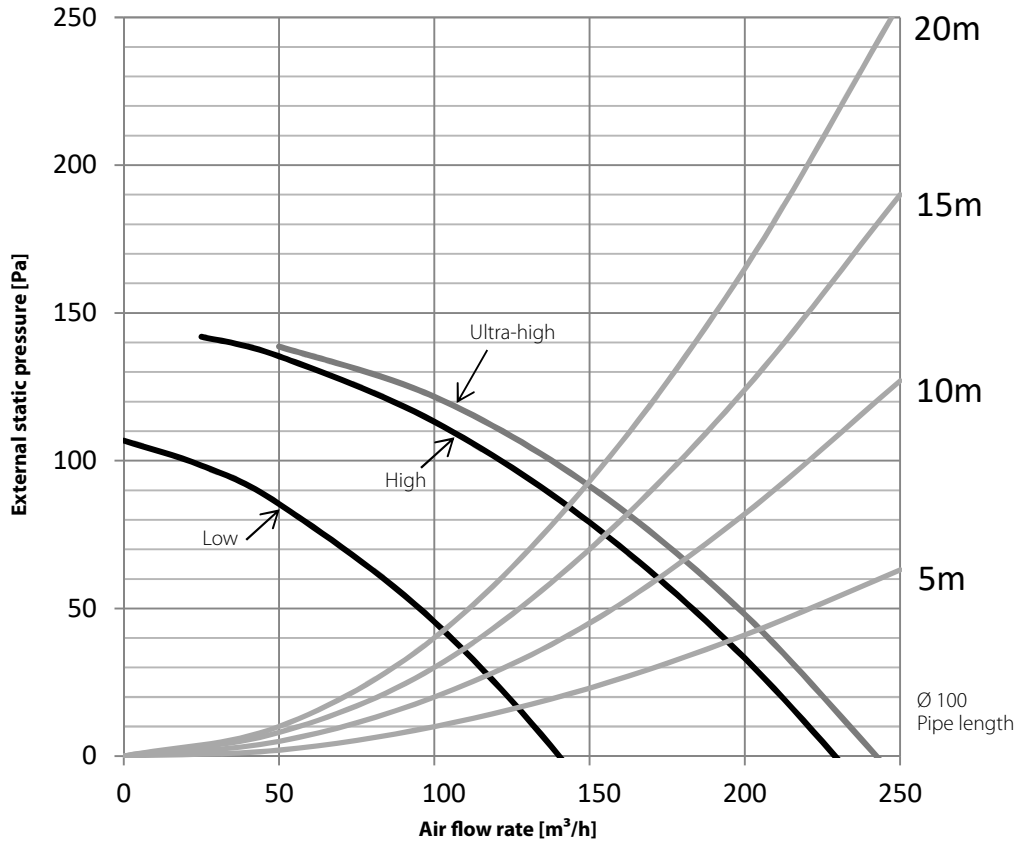

NOTES

1. The fan speeds are valid for ~230-V, ~50-Hz power supply.

4D100379A

VAM250FC

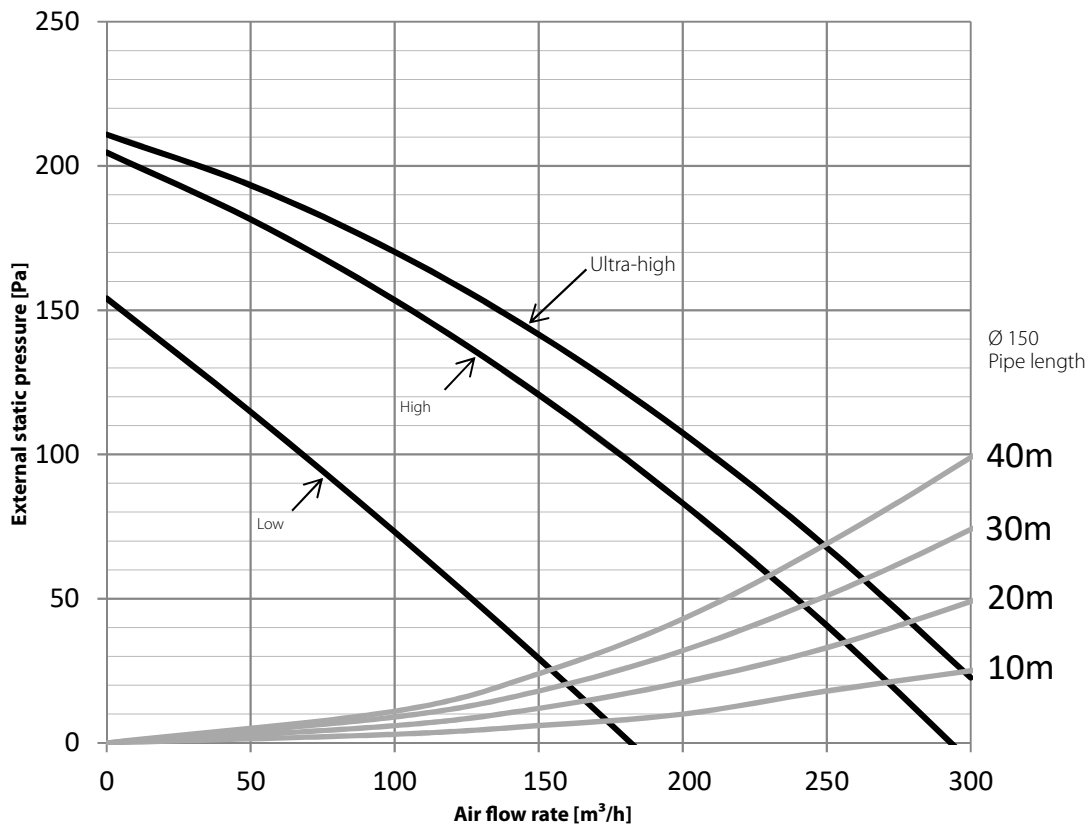

NOTES

1. The fan speeds are valid for ~230-V, ~50-Hz power supply.

4D100380A

DETAILED TECHNICAL DRAWINGS

VAM350J

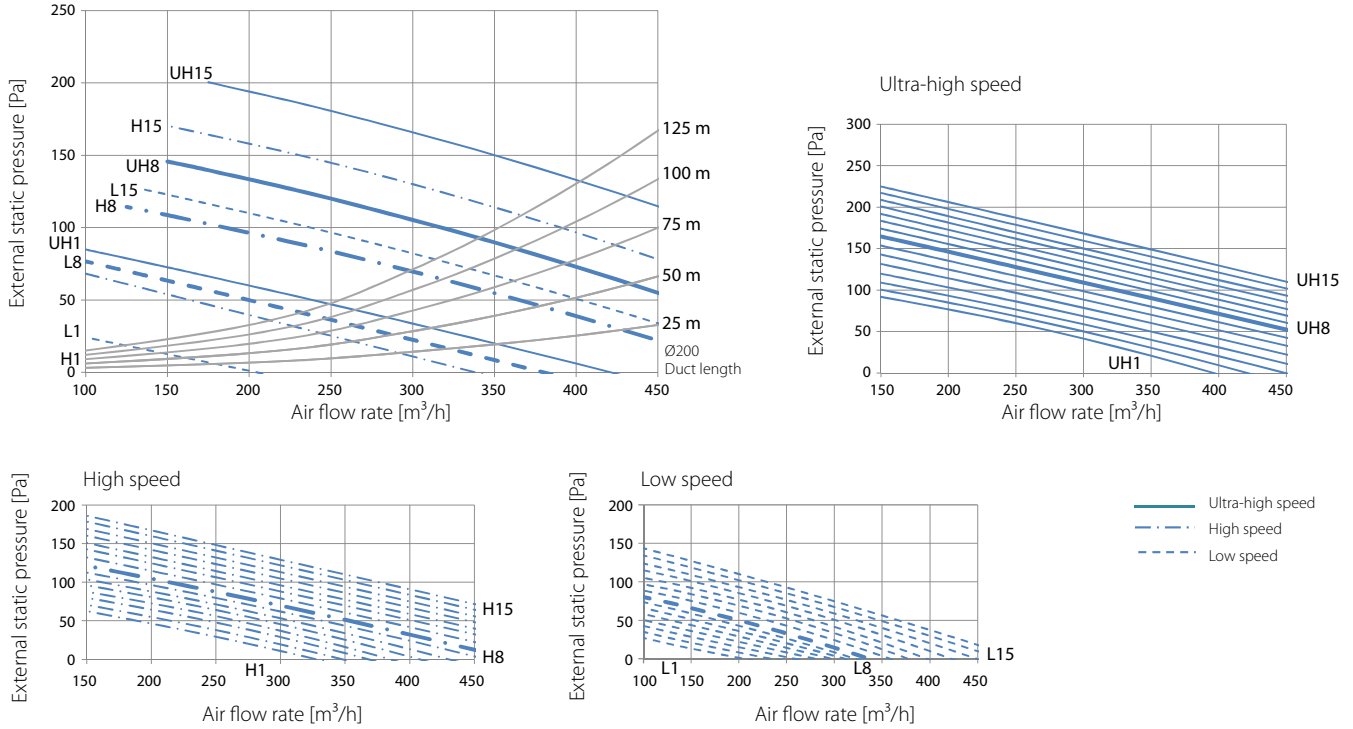

NOTES

- The fan curves are determined with $\cdot 1/3$ of the ESP on the outdoor side (EA & OA), and $\cdot 2/3$ of the ESP on the indoor side (RA & SA).
EA = Exhaust air
OA = Outdoor air
RA = Room air
SA = Supply air
- Measured according to JIS B 8628 - 2003.

LEGEND

- L1 = Low speed lower limit
- L8 = Low speed factory setting
- L15 = Low speed upper limit
- H1 = High speed lower limit
- H8 = High speed factory setting
- H15 = High speed upper limit
- UH1 = Ultra-high speed lower limit
- UH8 = Ultra-high speed factory setting
- UH15 = Ultra-high speed upper limit

3D113493B

VAM500J

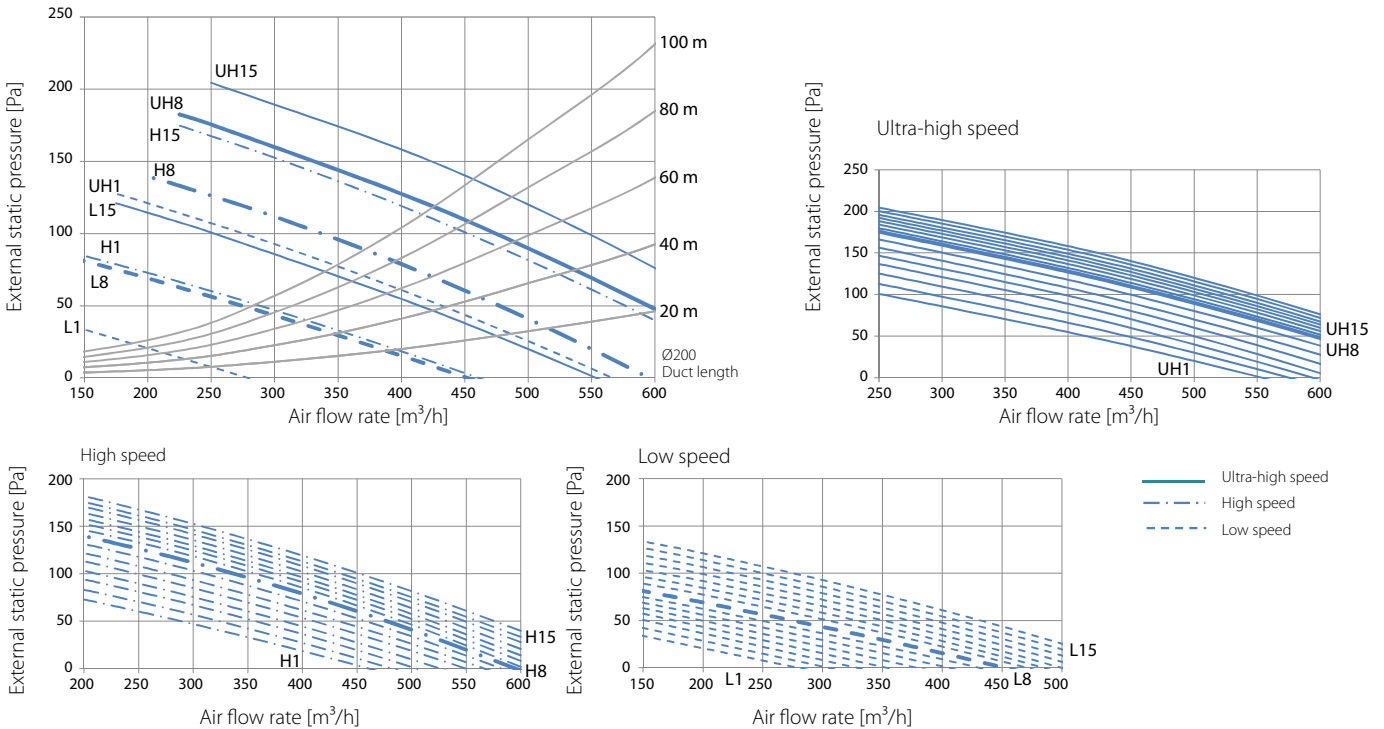

NOTES

- The fan curves are determined with $\cdot 1/3$ of the ESP on the outdoor side (EA & OA), and $\cdot 2/3$ of the ESP on the indoor side (RA & SA).
EA = Exhaust air
OA = Outdoor air
RA = Room air
SA = Supply air
- Measured according to JIS B 8628 - 2003.

LEGEND

- L1 = Low speed lower limit
- L8 = Low speed factory setting
- L15 = Low speed upper limit
- H1 = High speed lower limit
- H8 = High speed factory setting
- H15 = High speed upper limit
- UH1 = Ultra-high speed lower limit
- UH8 = Ultra-high speed factory setting
- UH15 = Ultra-high speed upper limit

3D113494B



VAM650J

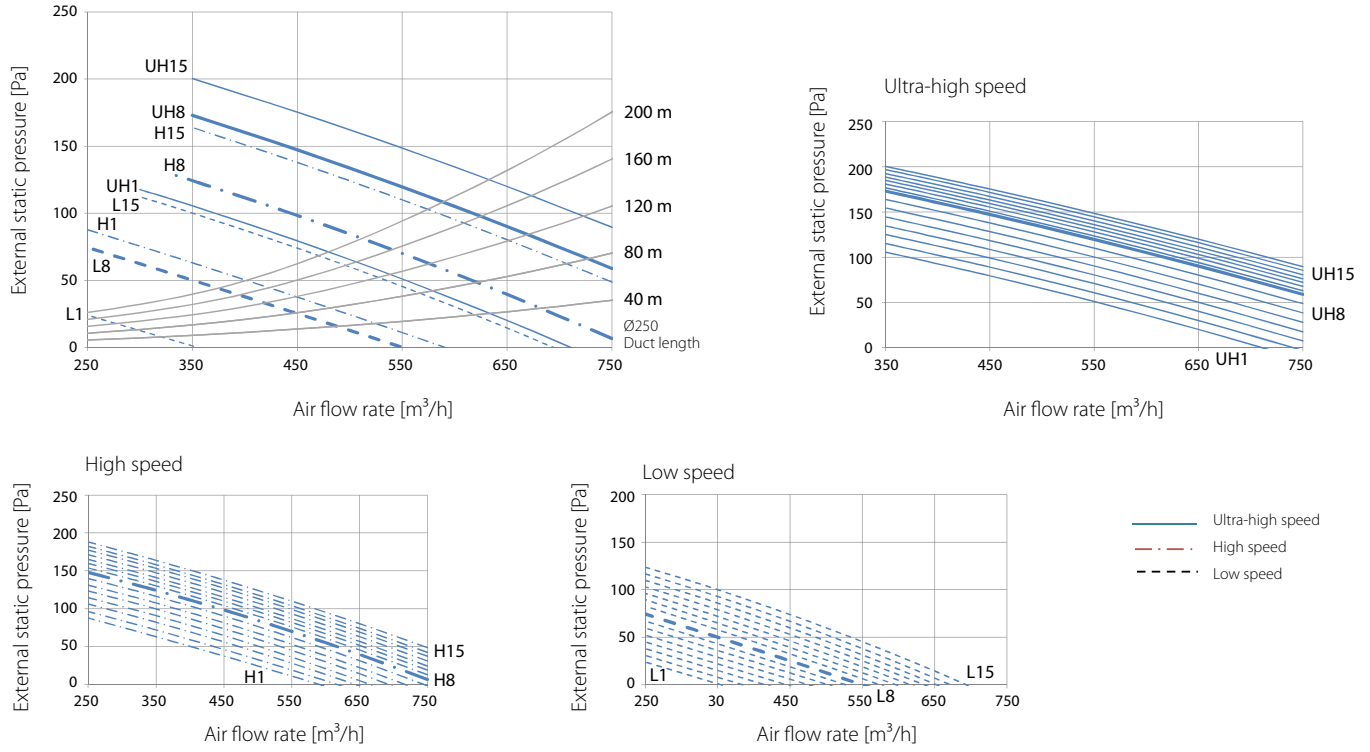

NOTES

- The fan curves are determined with 1/3 of the ESP on the outdoor side (EA & OA), and 2/3 of the ESP on the indoor side (RA & SA).
EA = Exhaust air
OA = Outdoor air
RA = Room air
SA = Supply air
- Measured according to JIS B 8628 - 2003.

LEGEND

- L1 = Low speed lower limit
- L8 = Low speed factory setting
- L15 = Low speed upper limit
- H1 = High speed lower limit
- H8 = High speed factory setting
- H15 = High speed upper limit
- UH1 = Ultra-high speed lower limit
- UH8 = Ultra-high speed factory setting
- UH15 = Ultra-high speed upper limit

3D113495B

VAM800J

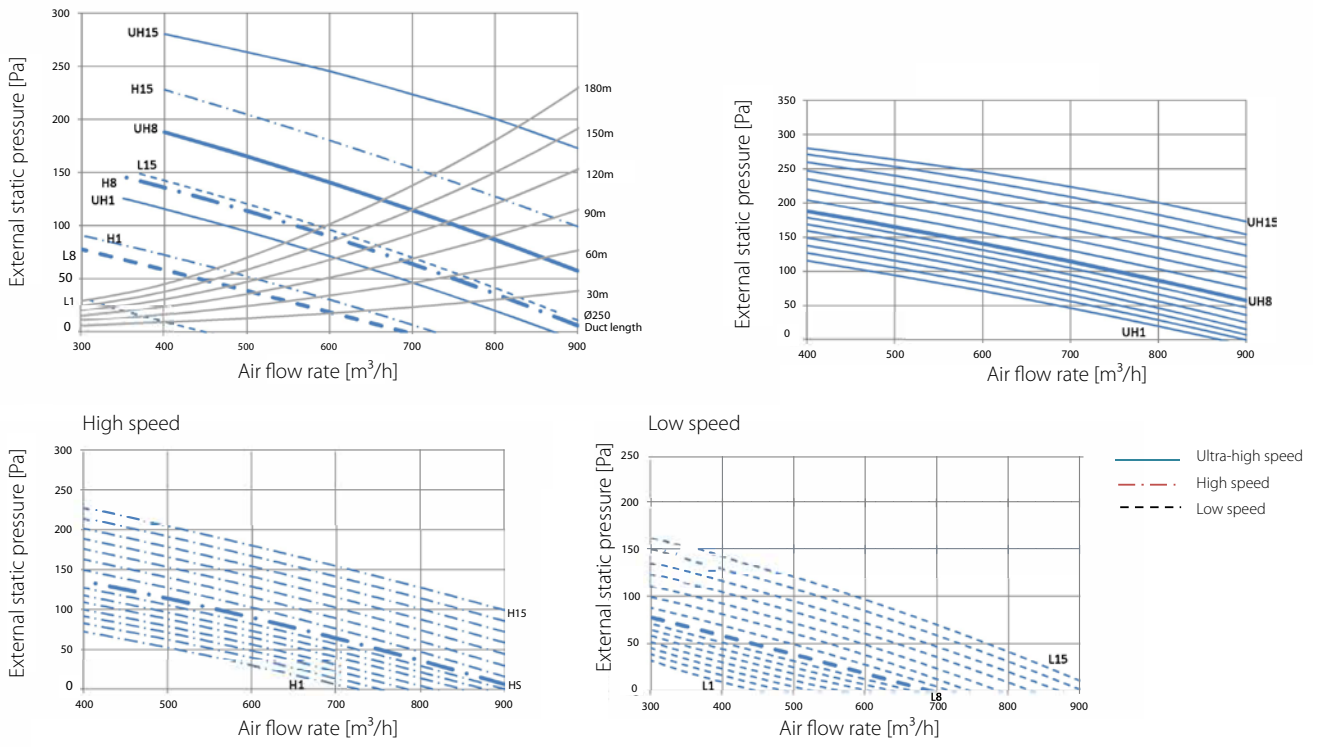

NOTES

- The fan curves are determined with 1/3 of the ESP on the outdoor side (EA & OA), and 2/3 of the ESP on the indoor side (RA & SA).
EA = Exhaust air
OA = Outdoor air
RA = Room air
SA = Supply air
- Measured according to JIS B 8628 - 2003.

LEGEND

- L1 = Low speed lower limit
- L8 = Low speed factory setting
- L15 = Low speed upper limit
- H1 = High speed lower limit
- H8 = High speed factory setting
- H15 = High speed upper limit
- UH1 = Ultra-high speed lower limit
- UH8 = Ultra-high speed factory setting
- UH15 = Ultra-high speed upper limit

3D112837A

DETAILED TECHNICAL DRAWINGS

VAM1000J

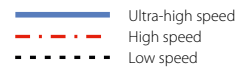
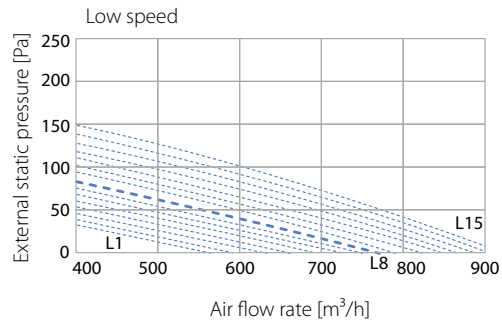
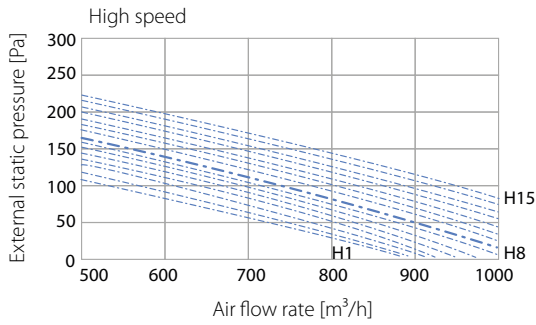
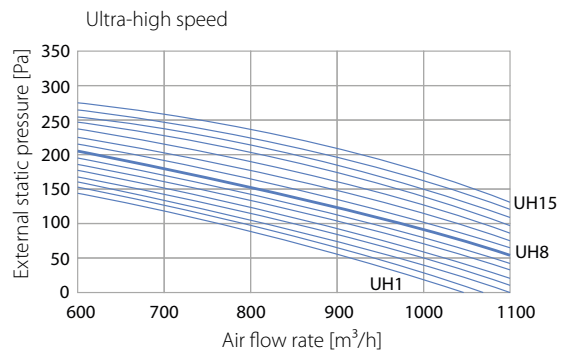
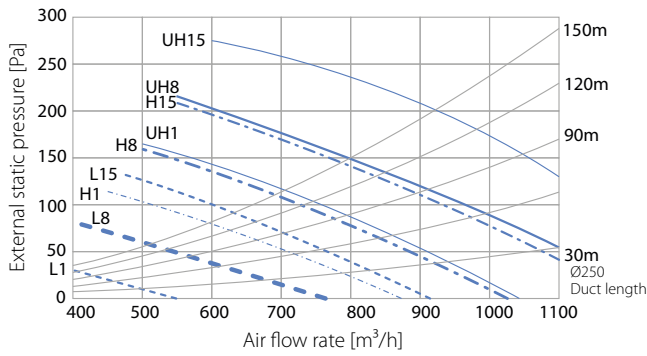

NOTES

- The fan curves are determined with 1/3 of the ESP on the outdoor side (EA & OA), and 2/3 of the ESP on the indoor side (RA & SA).
EA = Exhaust air
OA = Outdoor air
RA = Room air
SA = Supply air
- Measured according to JIS B 8628 - 2003.

LEGEND

- L1 = Low speed lower limit
- L8 = Low speed factory setting
- L15 = Low speed upper limit
- H1 = High speed lower limit
- H8 = High speed factory setting
- H15 = High speed upper limit
- UH1 = Ultra-high speed lower limit
- UH8 = Ultra-high speed factory setting
- UH15 = Ultra-high speed upper limit

3D112832A

VAM1500J

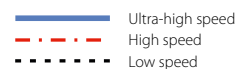
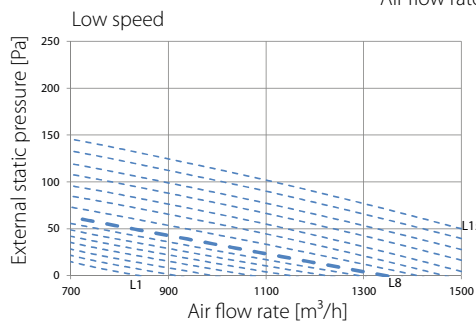
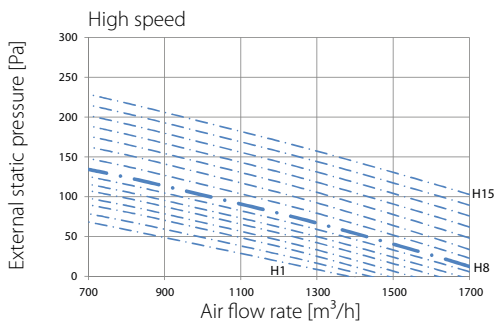
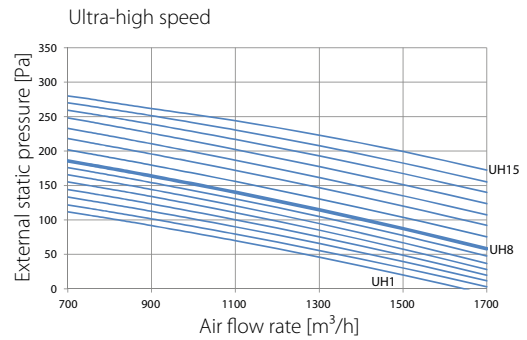
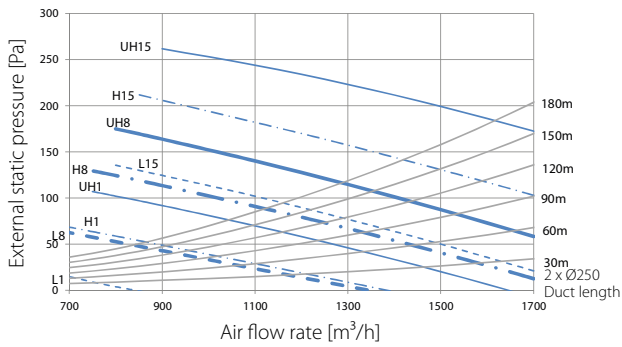

NOTES

- The fan curves are determined with 1/3 of the ESP on the outdoor side (EA & OA), and 2/3 of the ESP on the indoor side (RA & SA).
EA = Exhaust air
OA = Outdoor air
RA = Room air
SA = Supply air
- Measured according to JIS B 8628 - 2003.

LEGEND

- L1 = Low speed lower limit
- L8 = Low speed factory setting
- L15 = Low speed upper limit
- H1 = High speed lower limit
- H8 = High speed factory setting
- H15 = High speed upper limit
- UH1 = Ultra-high speed lower limit
- UH8 = Ultra-high speed factory setting
- UH15 = Ultra-high speed upper limit

3D112838A



VAM2000J

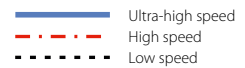
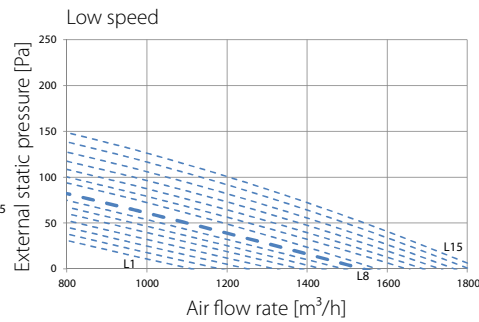
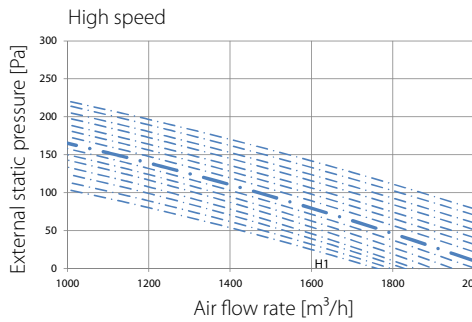
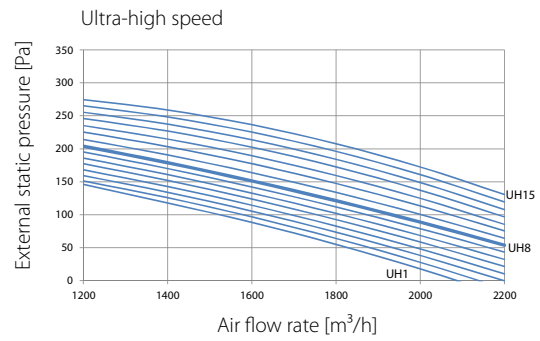
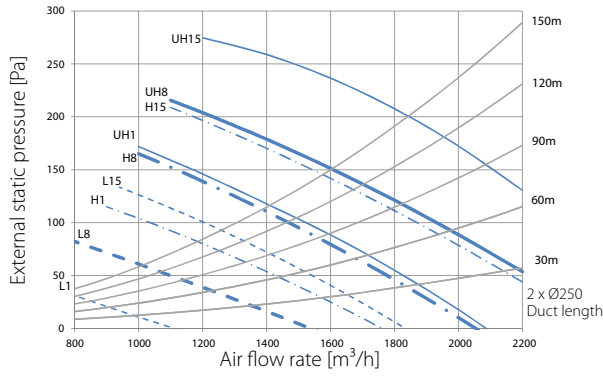

NOTES

- The fan curves are determined with 1/3 of the ESP on the outdoor side (EA & OA), and 2/3 of the ESP on the indoor side (RA & SA).
EA = Exhaust air
OA = Outdoor air
RA = Room air
SA = Supply air
- Measured according to JIS B 8628 - 2003.

LEGEND

- L1 = Low speed lower limit
- L8 = Low speed factory setting
- L15 = Low speed upper limit
- H1 = High speed lower limit
- H8 = High speed factory setting
- H15 = High speed upper limit
- UH1 = Ultra-high speed lower limit
- UH8 = Ultra-high speed factory setting
- UH15 = Ultra-high speed upper limit

3D112839A

DETAILED TECHNICAL DRAWINGS

EKVDX32A

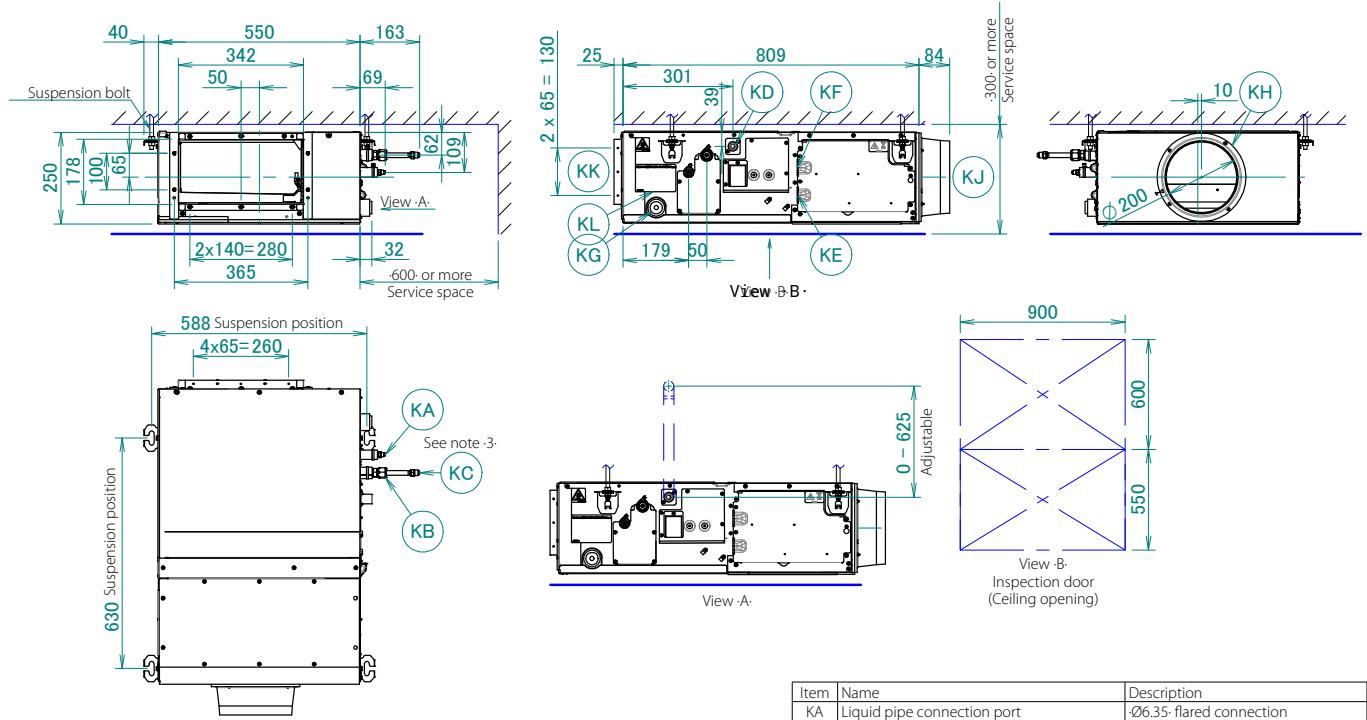

NOTES

1. When installing optional accessories, refer to their respective documentation.
2. The ceiling depth varies according to the documentation of the specific system.
3. Mandatory in case of using R32-refrigerant

Item	Name	Description
KA	Liquid pipe connection port	Ø6.35-flared connection
KB	Gas pipe connection port	Ø12.70-flared connection
KC	Accessory pipe	Ø9.52-flared connection
KD	Drain pipe connection	VP20 (OD Ø26, ID Ø20)
KE	Wiring connection	/
KF	Power supply connection	/
KG	Drain outlet	VP20 (OD Ø26, ID Ø20)
KH	Air inlet flange	/
KJ	Air suction side	/
KK	Air discharge side	/
KL	Nameplate	/

3D127967

EKVDX50A

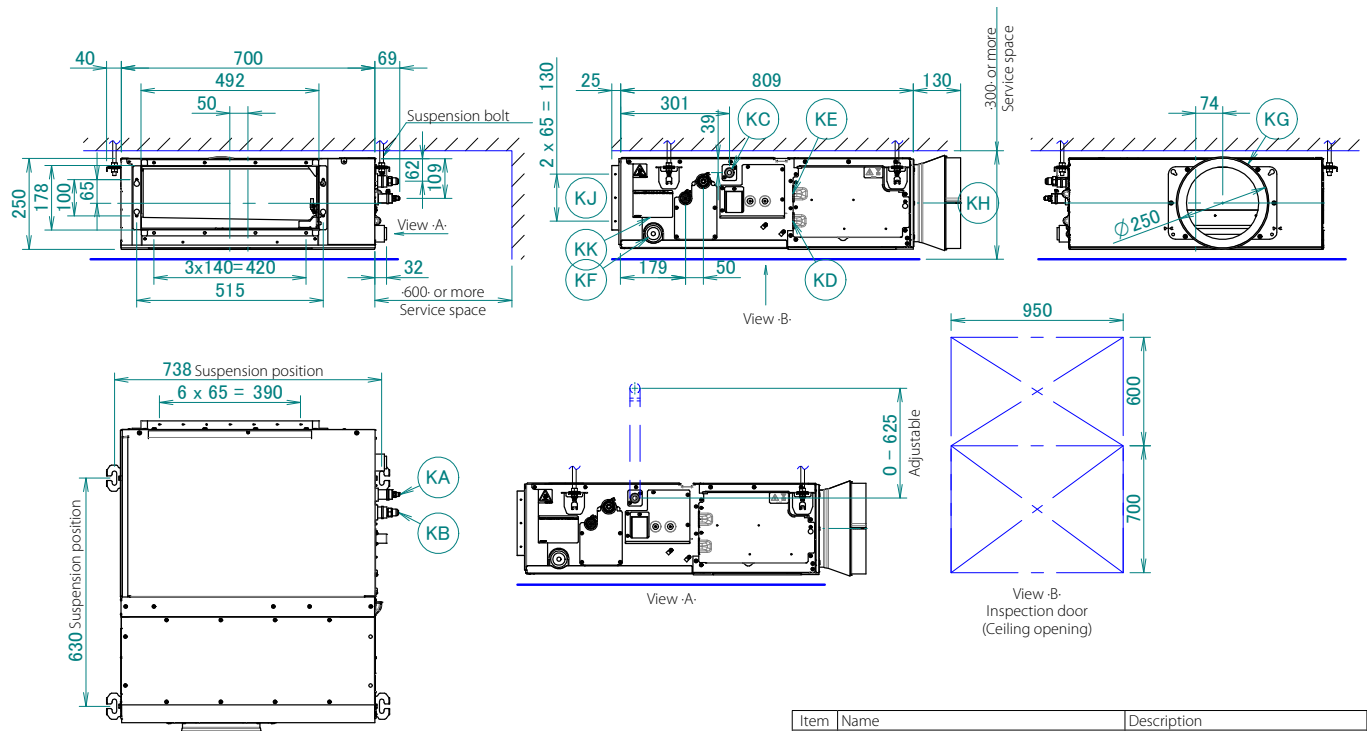

NOTES

1. When installing optional accessories, refer to their respective documentation.
2. The ceiling depth varies according to the documentation of the specific system.

Item	Name	Description
KA	Liquid pipe connection port	Ø6.35-flared connection
KB	Gas pipe connection port	Ø12.70-flared connection
KC	Drain pipe connection	VP20 (OD Ø26, ID Ø20)
KD	Wiring connection	/
KE	Power supply connection	/
KF	Drain outlet	VP20 (OD Ø26, ID Ø20)
KG	Air inlet flange	/
KH	Air suction side	/
KJ	Air discharge side	/
KK	Nameplate	/

3D127968

EKVDX80A

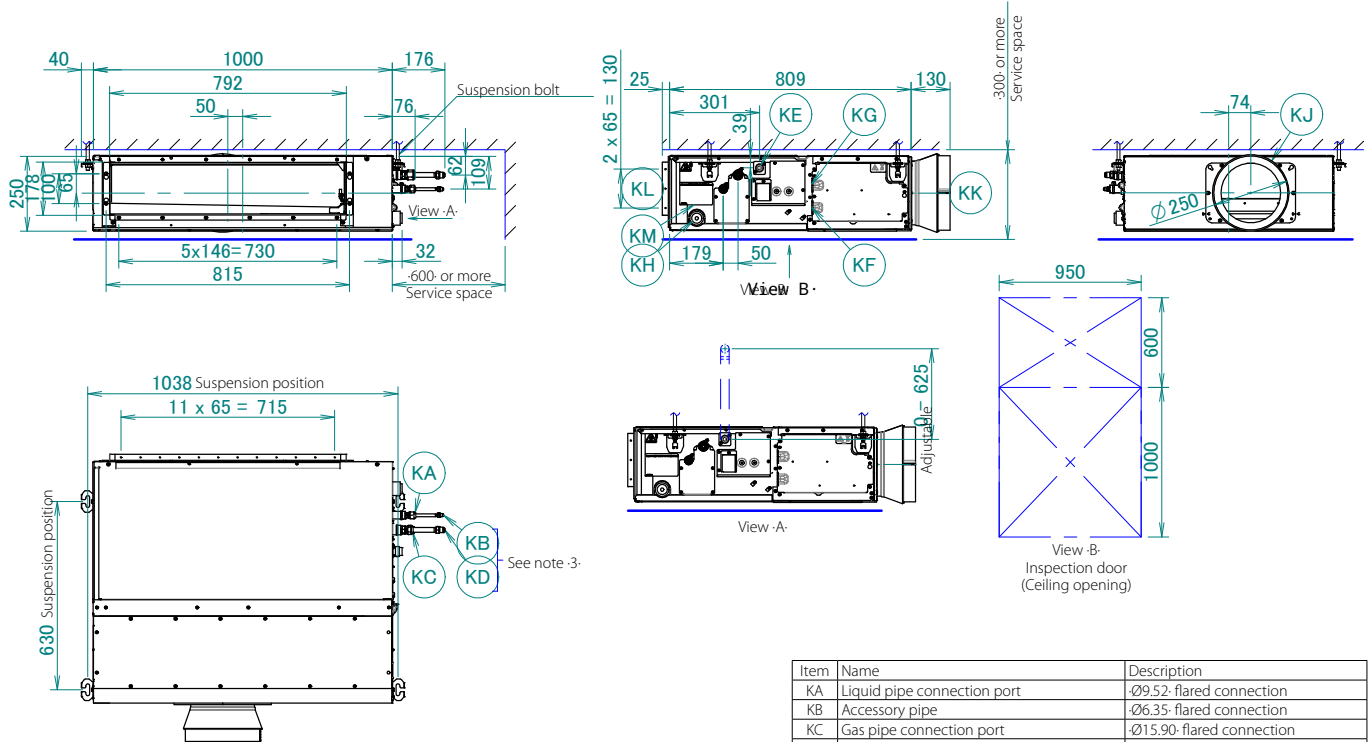

NOTES

1. When installing optional accessories, refer to their respective documentation.
2. The ceiling depth varies according to the documentation of the specific system.
3. Mandatory in case of using R32-refrigerant

Item	Name	Description
KA	Liquid pipe connection port	-Ø9.52- flared connection
KB	Accessory pipe	-Ø6.35- flared connection
KC	Gas pipe connection port	-Ø15.90- flared connection
KD	Accessory pipe	-Ø12.70- flared connection
KE	Drain pipe connection	VP20 (OD Ø26, ID Ø20)
KF	Wiring connection	/
KG	Power supply connection	/
KH	Drain outlet	VP20 (OD Ø26, ID Ø20)
KJ	Air inlet flange	/
KK	Air suction side	/
KL	Air discharge side	/
KM	Nameplate	/

3D127969

EKVDX100A

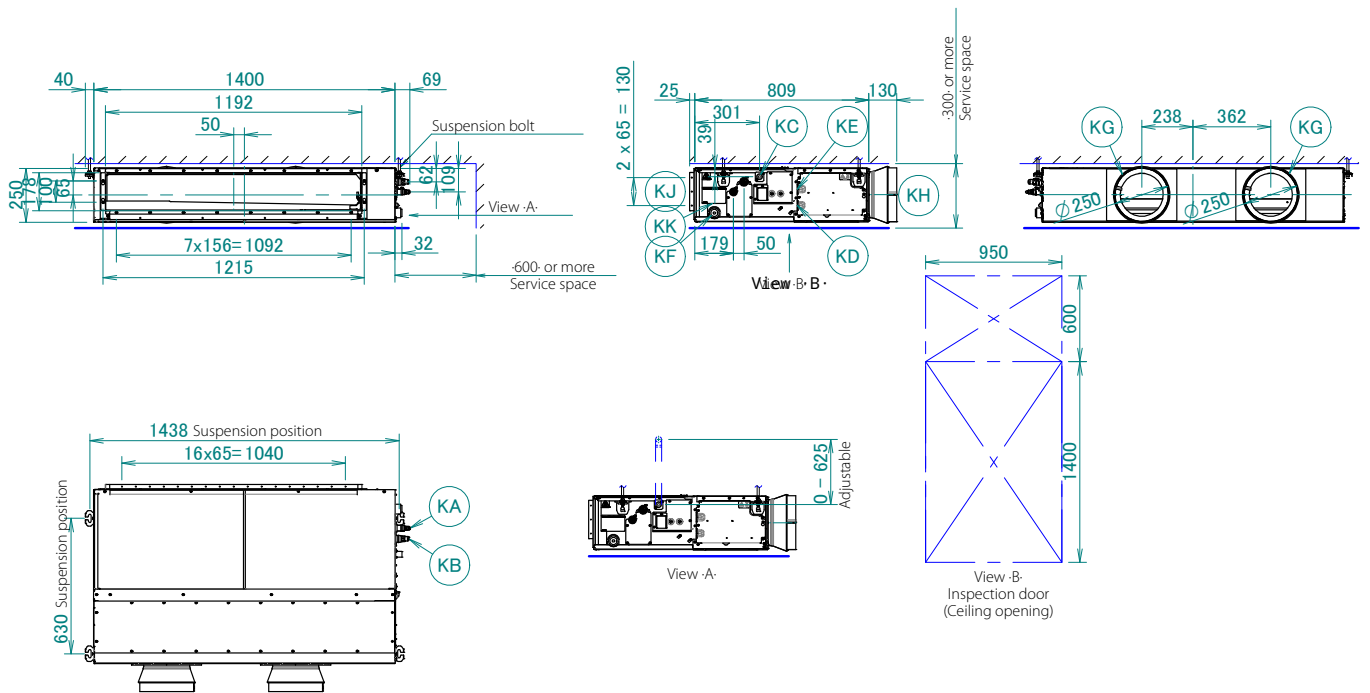

NOTES

1. When installing optional accessories, refer to their respective documentation.
2. The ceiling depth varies according to the documentation of the specific system.

Item	Name	Description
KA	Liquid pipe connection port	-Ø9.52- flared connection
KB	Gas pipe connection port	-Ø15.90- flared connection
KC	Drain pipe connection	VP20 (OD Ø26, ID Ø20)
KD	Wiring connection	/
KE	Power supply connection	/
KF	Drain outlet	VP20 (OD Ø26, ID Ø20)
KG	Air inlet flange	/
KH	Air suction side	/
KJ	Air discharge side	/
KK	Nameplate	/

3D127970

DETAILED TECHNICAL DRAWINGS

EKVDX32A

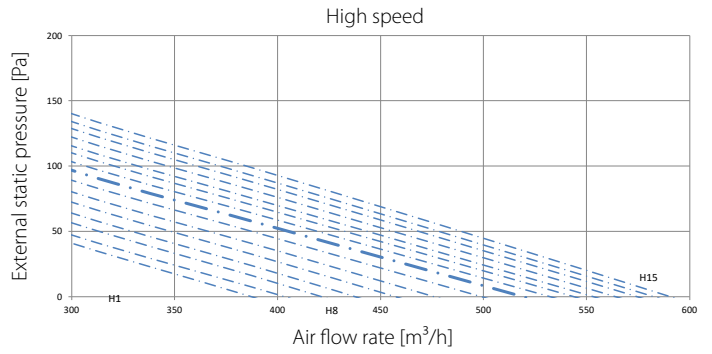
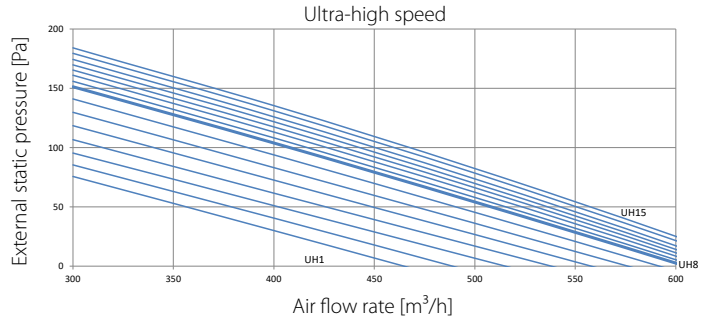
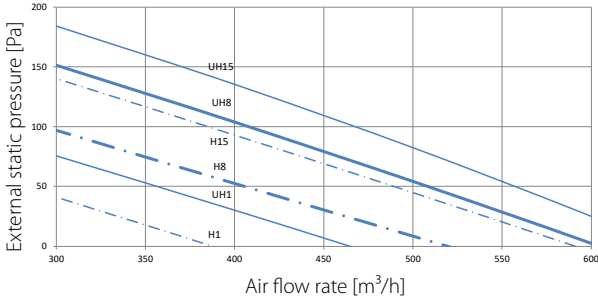

LEGEND

- H1 = High speed lower limit
- H8 = High speed factory setting
- H15 = High speed upper limit
- UH1 = Ultra-high speed lower limit
- UH8 = Ultra-high speed factory setting
- UH15 = Ultra-high speed upper limit

- Ultra-high speed
- - - High speed

NOTES

1. The fan curves are determined with -1/3- of the ESP on the outdoor side (-EA & OA), and -2/3- of the ESP on the indoor side (-RA & SA).
EA = Exhaust air
OA = Outdoor air
RA = Room air
SA = Supply air
2. The designed airflow of the system at H and UH tap should be kept as shown in the graphs. If the -VAM- airflow is out of this range, the compressor of the outdoor unit may stop for selfprotection purposes.
3. Unit operation with R32 refrigerant is possible in the shaded area of the graphs, but the R32 safety alarm will be triggered if the system airflow drops within this area during operation. No selection in this area is allowed.
4. Measured according to -JIS B 8628 - 2003-

3D138264

EKVDX50A

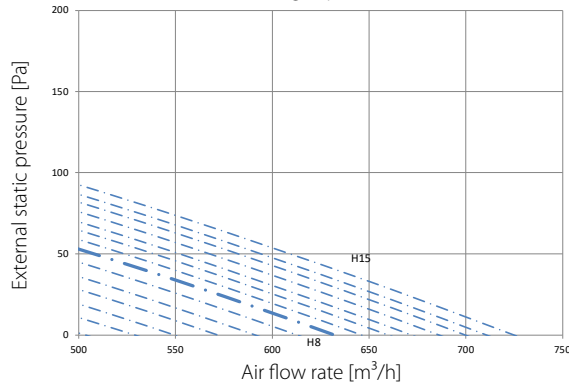
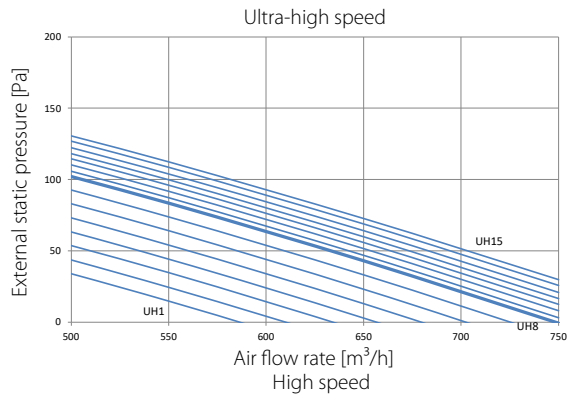
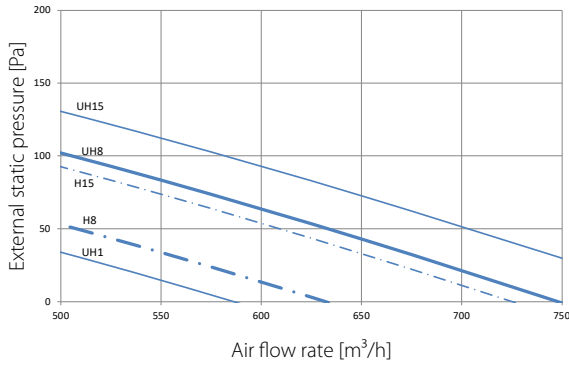

LEGEND

- H1 = High speed lower limit
- H8 = High speed factory setting
- H15 = High speed upper limit
- UH1 = Ultra-high speed lower limit
- UH8 = Ultra-high speed factory setting
- UH15 = Ultra-high speed upper limit

- Ultra-high speed
- - - High speed

NOTES

1. The fan curves are determined with -1/3- of the ESP on the outdoor side (-EA & OA), and -2/3- of the ESP on the indoor side (-RA & SA).
EA = Exhaust air
OA = Outdoor air
RA = Room air
SA = Supply air
2. The designed airflow of the system at H and UH tap should be kept as shown in the graphs. If the -VAM- airflow is out of this range, the compressor of the outdoor unit may stop for selfprotection purposes.
3. Measured according to -JIS B 8628 - 2003-

3D138265



EKVDX50A

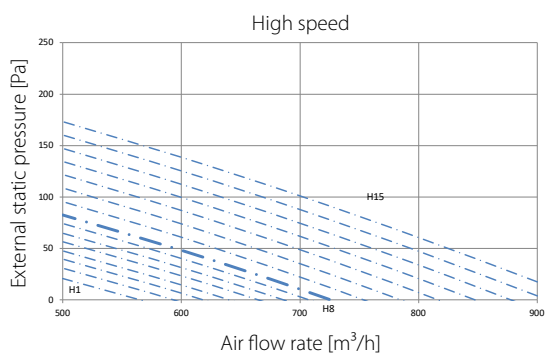
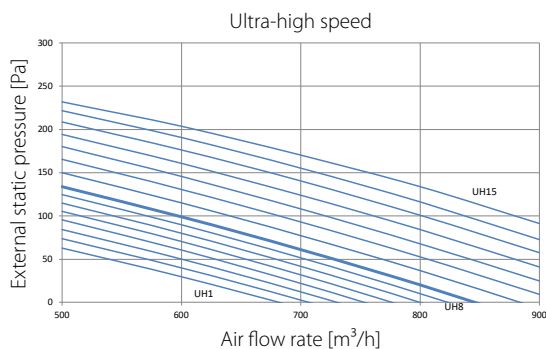
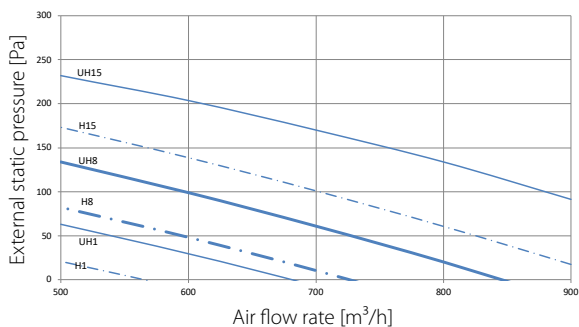

LEGEND

- H1 = High speed lower limit
- H8 = High speed factory setting
- H15 = High speed upper limit
- UH1 = Ultra-high speed lower limit
- UH8 = Ultra-high speed factory setting
- UH15 = Ultra-high speed upper limit

- Ultra-high speed
- - - High speed

NOTES

- The fan curves are determined with $\cdot 1/3$ of the ESP on the outdoor side (EA & OA), and $\cdot 2/3$ of the ESP on the indoor side (RA & SA).
EA = Exhaust air
OA = Outdoor air
RA = Room air
SA = Supply air
- The designed airflow of the system at H and UH tap should be kept as shown in the graphs. If the $\cdot VAM$ airflow is out of this range, the compressor of the outdoor unit may stop for self-protection purposes.
- Measured according to JIS B 8628 - 2003.

3D138266

EKVDX80A

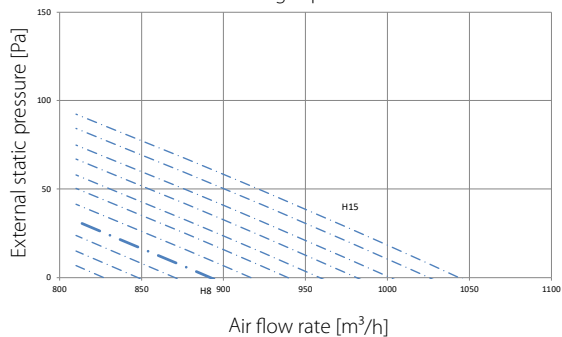
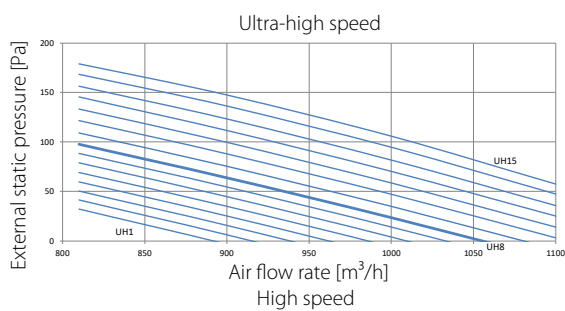
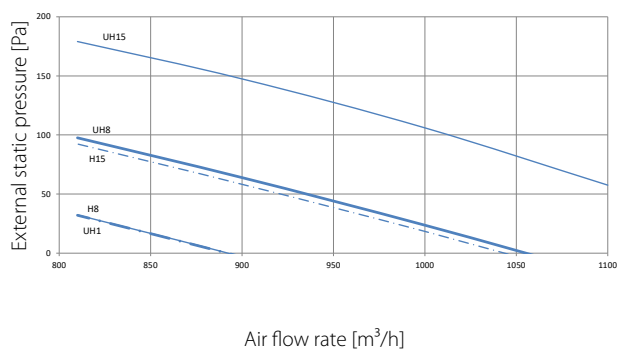

LEGEND

- H1 = High speed lower limit
- H8 = High speed factory setting
- H15 = High speed upper limit
- UH1 = Ultra-high speed lower limit
- UH8 = Ultra-high speed factory setting
- UH15 = Ultra-high speed upper limit

- Ultra-high speed
- - - High speed

NOTES

- The fan curves are determined with $\cdot 1/3$ of the ESP on the outdoor side (EA & OA), and $\cdot 2/3$ of the ESP on the indoor side (RA & SA).
EA = Exhaust air
OA = Outdoor air
RA = Room air
SA = Supply air
- The designed airflow of the system at H and UH tap should be kept as shown in the graphs. If the $\cdot VAM$ airflow is out of this range, the compressor of the outdoor unit may stop for self-protection purposes.
- Measured according to JIS B 8628 - 2003.

3D138267

DETAILED TECHNICAL DRAWINGS

EKVDX100A

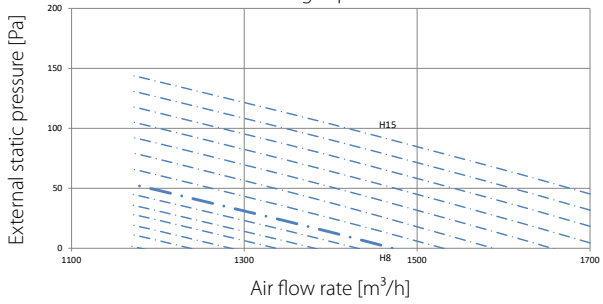
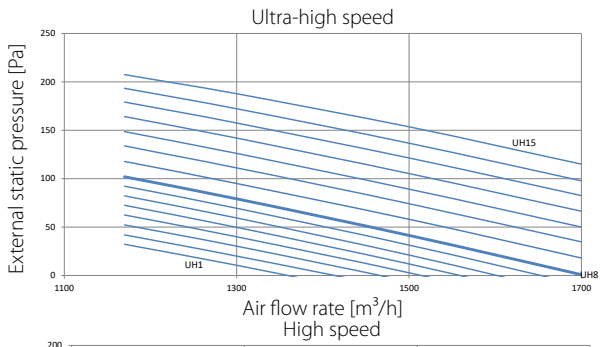
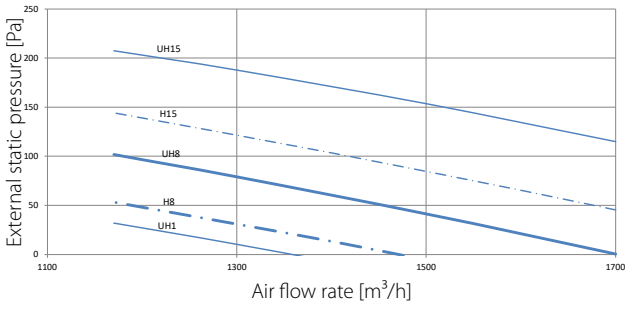

LEGEND

- H1 = High speed lower limit
- H8 = High speed factory setting
- H15 = High speed upper limit
- UH1 = Ultra-high speed lower limit
- UH8 = Ultra-high speed factory setting
- UH15 = Ultra-high speed upper limit

- Ultra-high speed
- - - High speed

NOTES

1. The fan curves are determined with $\cdot 1/3$ of the ESP on the outdoor side (EA & OA), and $\cdot 2/3$ of the ESP on the indoor side (RA & SA).
EA = Exhaust air
OA = Outdoor air
RA = Room air
SA = Supply air
2. The designed airflow of the system at H and UH tap should be kept as shown in the graphs. If the $\cdot VAM$ airflow is out of this range, the compressor of the outdoor unit may stop for selfprotection purposes.
3. Measured according to JIS B 8628 - 2003.

3D138268

EKVDX100A

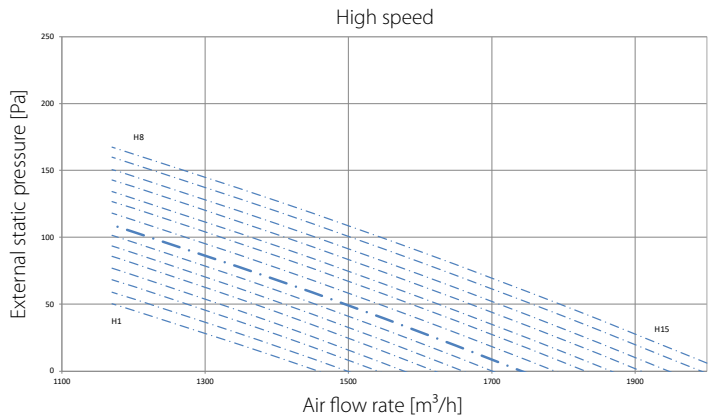
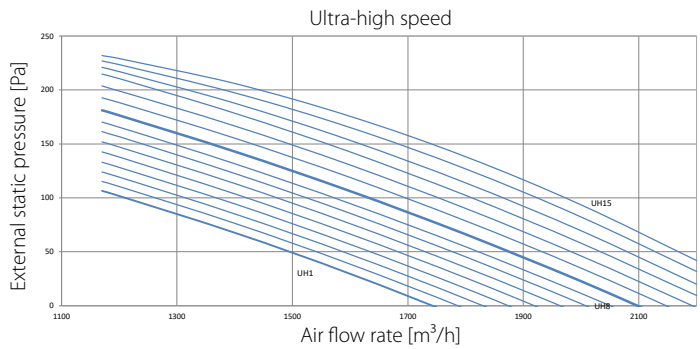
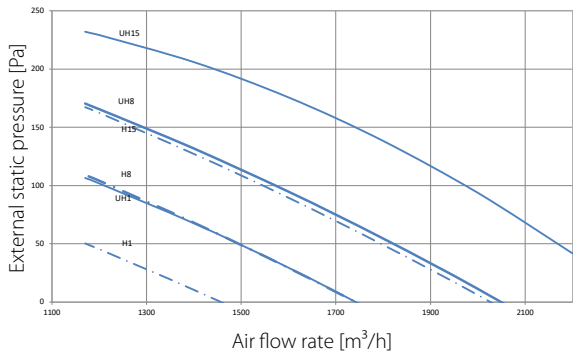

LEGEND

- H1 = High speed lower limit
- H8 = High speed factory setting
- H15 = High speed upper limit
- UH1 = Ultra-high speed lower limit
- UH8 = Ultra-high speed factory setting
- UH15 = Ultra-high speed upper limit

- Ultra-high speed
- - - High speed

NOTES

1. The fan curves are determined with $\cdot 1/3$ of the ESP on the outdoor side (EA & OA), and $\cdot 2/3$ of the ESP on the indoor side (RA & SA).
EA = Exhaust air
OA = Outdoor air
RA = Room air
SA = Supply air
2. The designed airflow of the system at H and UH tap should be kept as shown in the graphs. If the $\cdot VAM$ airflow is out of this range, the compressor of the outdoor unit may stop for selfprotection purposes.
3. Measured according to JIS B 8628 - 2003.

3D138269



More flexibility for your business with single fan casings in the whole Sky Air range

Unique to the market: We proudly present our low-height single fan outdoor units across all Sky Air ranges – from 3.5 to 25 kW.

- More flexibility in positioning, easier transport and installation
- Market-leading serviceability and handling – with easy access to all components and 7-segment display
- Reliable cooling thanks to refrigerant cooled PCB
- Full portfolio of connectable R-32 indoor units

www.daikin.eu/skyairbluevolution

BLUEvolution

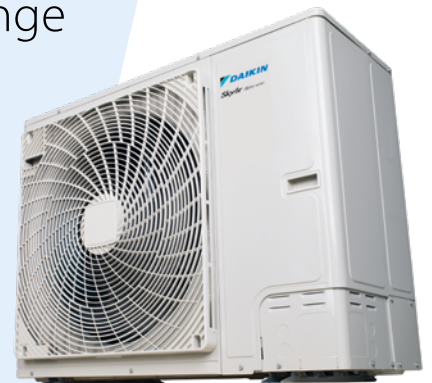

SkyAir
Alpha-series

SkyAir
Advance-series

Daikin Europe N.V. Naamloze Vennootschap Zandvoordestraat 300 · 8400 Oostende · Belgium · www.daikin.eu · BE 0412 120 336 · RPR Oostende (Publisher)

05/24 ECPEN24-100



Daikin Europe N.V. participates in the Eurovent Certified Performance programme for Fan Coil Units and Variable Refrigerant Flow systems.

Daikin Applied Europe S.p.A. participates in the Eurovent Certified Performance programme for Liquid Chilling Packages, Hydronic Heat Pumps and Air Handling Units.

Check ongoing validity of certificate: www.eurovent-certification.com



The present publication is drawn up by way of information only and does not constitute an offer binding upon Daikin Europe N.V. Daikin Europe N.V. has compiled the content of this publication to the best of its knowledge. No express or implied warranty is given for the completeness, accuracy, reliability or fitness for particular purpose of its content and the products and services presented therein. Specifications are subject to change without prior notice. Daikin Europe N.V. explicitly rejects any liability for any direct or indirect damage, in the broadest sense, arising from or related to the use and/or interpretation of this publication. All content is copyrighted by Daikin Europe N.V.