

Hot Water Module

Mid temperature type

MMW-UP0271LQ-E
MMW-UP0271LQ-TR
MMW-UP0561LQ-E
MMW-UP0561LQ-TR

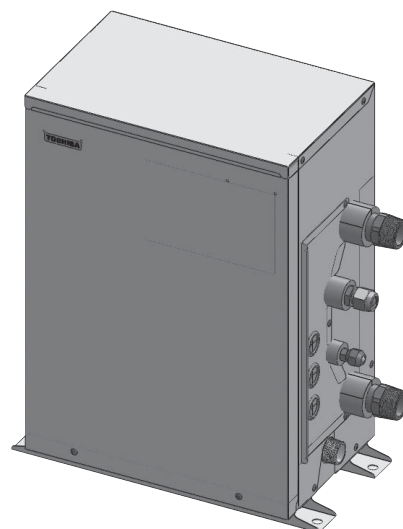

Contents

1. Summaries of product characteristics
2. Specifications
3. Dimensional drawing
4. Center of gravity
5. Refrigerant cycle diagram
6. Wiring diagram
7. Optional connector specifications
8. Electrical characteristics
9. External wiring diagram
10. Water side characteristics
11. Sound data
12. Caution of installation

1. Summaries of product characteristics

CONCEPT

- To design and produce a mid temperature hot water module, capable of producing up to 50°C outlet water temperature, whilst maximizing the performance and efficiency of the entire VRF system.
- To be used in both space heating and domestic hot water applications. Typical applications include hotel, office and residential apartment suits.
- To create a single solution for our customers heating and domestic hot water requirements.

Mid temperature Hot Water Module – CHARACTER

- New Design, specifically engineered for VRF application
- Operating Control designed specifically to maximize both performance and efficiency.
- Capacity line up - 8 kW - 16 kW
- All models come in single phase (220 – 240 V ~ 50 Hz)

Domestic Hot Water Installation Example

Typical Installations examples include –

- Office use, where there is a requirement for DHW, such as small canteen or rest room.
- Apartment block, where there is a requirement for DHW, such as kitchen, shower and bath.
- Hotel use, where there is an auxiliary requirement for DHW, for the purpose of cleaning and sanitary operations.
- Small Businesses, for example coffee shops, hairdressers etc, where there is a requirement for a single heating solution.

Space Heating Installation Example

Typical Installations examples include –

- Office use, where there is a requirement for space heating via fan coils or AHU's.
- Apartment, where there is a requirement for space heating via under-floor heating.
- Hotel use, where there is an auxiliary requirement for space heating via a combination of fan coils, AHU or under-floor heating circuits.
- Small Businesses, for example coffee shops, hairdressers etc, where there is a requirement for a single heating solution.

Connectable units

VRF products

ODU type	Factory	Model name
SMMS-e	TCTC	MMY-MAP**06HT8P-E/TR
SHRM-e	TCTC	MMY-MAP**06FT8P-E/TR
SMMS-u	TCTC	MMY-MUP**01HT8P-E/TR
Mini SMMS-e	TCAC	MCY-MHP**06HS8-E/TR
SHRM-A	TCTC	MMY-SUG**01MT8P-E

- The Fresh Air Intake type and Air to Air Heat Exchanger with DX Coil cannot be connected with the same refrigerant system.
- The BMS units cannot be used because it does not support HWM.

Remote controller (TCC-LINK)

- RBC-AMT32E
- RBC-AMS41E
- RBC-AMS55E-ES/EN
- RBC-AS41E
- RBC-ASC11E/TR
- RBC-ASC21E
- TCB-EXS21TLE

Remote controller (TU2C-LINK) * SHRM-A can only be used with the following remote controllers.

- RBC-ASCU11-E/TR
- RBC-AMTU31-E/TR
- RBC-AMSU51-ES/EN

Allowable length / height difference of refrigerant piping

■ System able to be combined

Mid temperature Hot Water Module (M-HWM) is connectable to SMMS-e, SHRM-e and MiNi SMMS-e (8-10 HP).
 The system does not work when it connect to the MiNi SMMS, MiNi SMMS-e and SMMS-i (5, 6 HP).
 The Fresh Air intake type and Air to Air Heat Exchanger with DX Coil cannot be connected with the same refrigerant system.

■ In case of SMMS-e system

SMMS-e system restrictions

M-HWM connection		Without M-HWM	With M-HWM
Max. No. of combined outdoor units		3 units	3 units
Max. capacity of combined outdoor units		60 HP	60 HP
Max. No. of combined indoor units		64 units	64 units
Max. capacity of combined indoor units and M-HWM	H2 ≤ 15 m	135%	115%
	H2 > 15 m	105%	105%

M-HWM: Mid temperature Hot Water Module

Restriction on Mid temperature Hot Water Module (M-HWM) connection

Indoor connection capacity (*1)	Total	Standard indoor unit + M-HWM	65 - 115% (*1)
	Allowed capacity	Standard indoor unit	50 - 115%
Number of combined indoor units and M-HWM	Total	Standard indoor unit + M-HWM	2 - 64
	Allowed number	Standard indoor unit	2 - 64
		M-HWM	0 - 2

*1: Ratio of connected total indoor unit capacity to outdoor unit capacity.
 *2: M-HWM connecting capacity should be smaller than standard indoor unit.

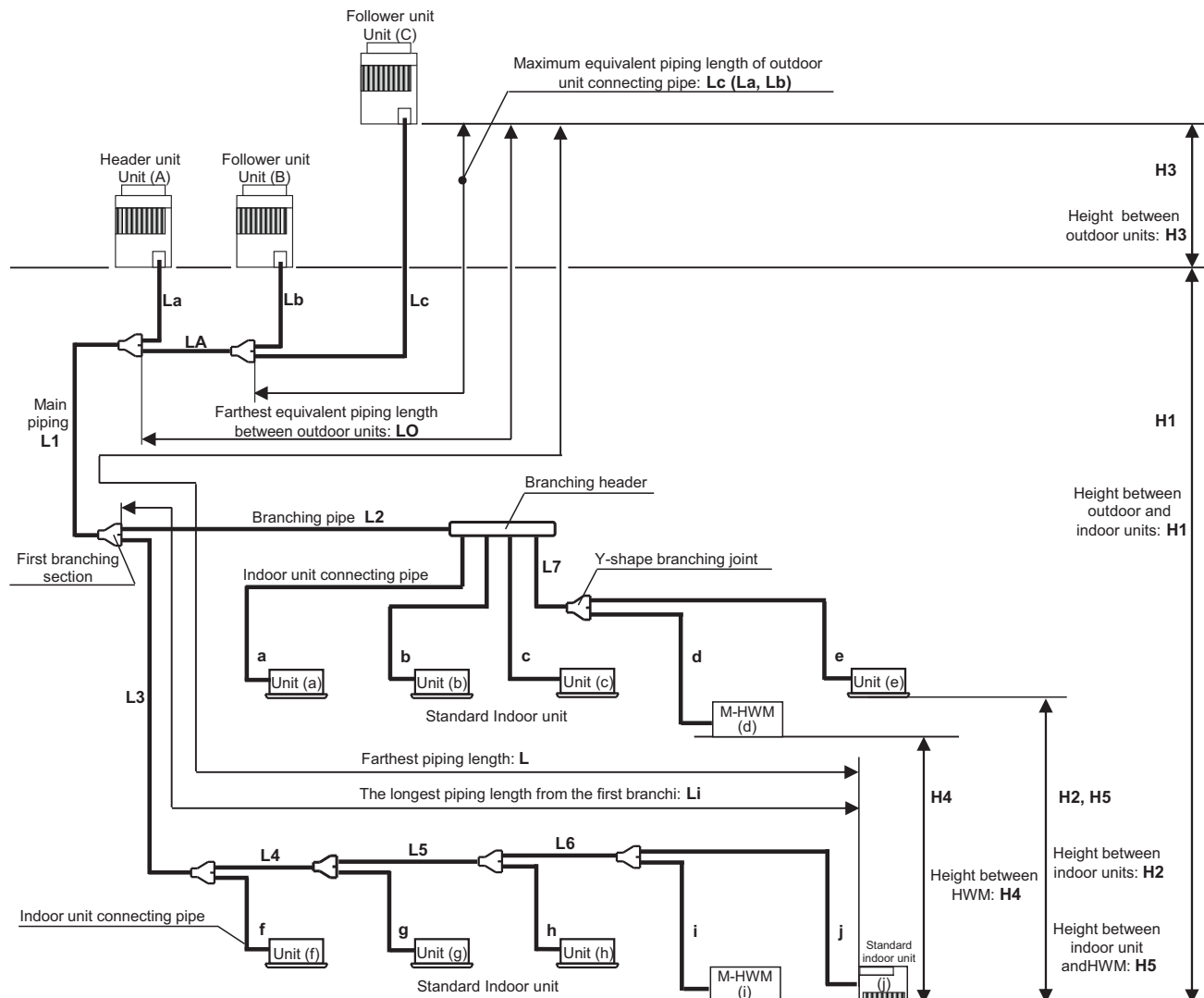

Item	SMMS-e		Pipes		
	Without M-HWM	With M-HWM			
Pipe length	Total extension of pipe (liquid pipe, real length)	Below 34 HP 34 HP or more	1000 m (*2) 1000 m (*2)	LA + La + Lb + Lc + L1 + L2 + L3 + L4 + L5 + L6 + L7 + a + b + c + d + e + f + g + h + i + j	
	Farthest piping length L (*1)	Equivalent length	235 m	235 m	Lc + LA + L1 + L3 + L4 + L5 + L6 + j
		Real length	190 m	190 m	
	Maximum equivalent length of main piping L1	Equivalent length	120 m (*3)	120 m (*3)	L1
		Real length	100 m (*3)	100 m (*3)	
	Farthest equivalent piping length from the first branch Li (*1)	H1 > 3 m	65 m	65 m	L3 + L4 + L5 + L6 + j
		H1 ≤ 3 m	90 m	90 m	
	Farthest equivalent piping length between outdoor units LO (*1)		25 m	25 m	LA + Lc (LA + Lb)
	Maximum equivalent length of pipes connected to outdoor units		10 m	10 m	Lc (La, Lb)
	Maximum real length of indoor unit connecting piping		30 m	30 m	a, b, c, d, e, f, g, h, i, j
Maximum equivalent length between branches		50 m	50 m	L2, L3, L4, L5, L6, L7	
Height difference	Height between outdoor and indoor units H1	Upper outdoor units	70 m (*4)(*7)	70 m (*4)(*7)	—
		Lower outdoor units	40 m (*5)	40 m (*5)	
	Height between indoor units H2	Upper outdoor units	40 m	3 m (*6 40 m)	—
		Lower outdoor units	40 m	10 m (*6 40 m)	
	Height between HWM H4	Upper outdoor units	—	3 m	—
		Lower outdoor units	—	—	
	Height between indoor units and HWM H5	Upper outdoor units	—	3 m (*6 40 m)	—
		Lower outdoor units	—	10 m (*6 40 m)	
Height between outdoor units H3		5 m	5 m	—	

- *1: Furthest outdoor unit from the first branch: (C), furthest indoor unit: (j).
- *2: Total charging refrigerant is 140 kg or less.
- *3: If the max. combined outdoor unit capacity is 54 HP or more, than max. equivalent length is 70 m or less (real length is 50 m or less).
- *4: If the height difference between indoor units (H2) exceeds 3 m, set 50 m or less.
- *5: If the height difference between indoor units (H2) exceeds 3 m, set 30 m or less.
- *6: If the Hot Water Module and indoor units are not operating at the same time.
- *7: Extension up till 90 m is possible with conditions below.
 - Outside Temperature Cooling operation : 10°C to 46°C (Dry-bulb temp.)
 - Heating operation : -5°C to 15.5°C (Wet-bulb temp.)
 - Equivalent length of farthest piping from 1st branching Li < 50 m
 - Real length of main piping L1 < 100 m
 - Height difference between indoor units H2 < 3 m
 - Total capacity of connectable indoor units: 90% - 105%
 - Single CDU, and up to 20 HP
 - Minimum capacity of connectable indoor: unit 4 HP or Larger

Outdoor unit connectable indoor units

▼ Capacity code of Mid temperature Hot water module
The capacity code of the Hot water module is different from the capacity code of the standard indoor unit.

Mid temperature Hot water module		MMW-UP0271LQ-E, -TR	MMW-UP0561LQ-E, -TR
Capacity rank type		027	056
Capacity code	Equivalent to HP (HP)	2.5	5
Equivalent to capacity	(kW)	7.1	14.0

▼ Capacity code of standard indoor unit

Capacity rank type	005	007	009	012	015	018	024	027	030	036	048	056	072	096
Capacity code	0.6	0.8	1	1.25	1.7	2	2.5	3	3.2	4	5	6	8	10
Equivalent to capacity	1.7	2.2	2.8	3.6	4.5	5.6	7.1	8.0	9.0	11.2	14.0	16.0	22.4	28.0

SMMS-e	Capacity code of outdoor unit (HP)	Max. No. of combined indoor units and M-HWM	Total capacity code of indoor units (HP) Standard indoor unit + M-HWM		
			H2, H4, H5 ≤ 15 m	H2, H4, H5 > 15 m	
			Total capacity 65 - 115%	Total capacity 65 - 105%	
Standard model	MMY-MAP0806HT8P	8	18	5.2 to 9.2	5.2 to 8.4
	MMY-MAP1006HT8P	10	22	6.5 to 11.5	6.5 to 10.5
	MMY-MAP1206HT8P	12	27	7.8 to 13.8	7.8 to 12.6
	MMY-MAP1406HT8P	14	31	9.1 to 16.1	9.1 to 14.7
	MMY-MAP1606HT8P	16	36	10.4 to 18.4	10.4 to 16.8
	MMY-MAP1806HT8P	18	40	11.7 to 20.7	11.7 to 18.9
	MMY-MAP2006HT8P	20	45	13.0 to 23.0	13.0 to 21.0
	MMY-MAP2206HT8P	22	49	14.3 to 25.3	14.3 to 23.1
	MMY-AP2416HT8P	24	54	15.6 to 27.6	15.6 to 25.2
	MMY-AP2616HT8P	26	58	16.9 to 29.9	16.9 to 27.3
	MMY-AP2816HT8P	28	63	18.2 to 32.2	18.2 to 29.4
	MMY-AP3016HT8P	30	64	19.5 to 34.5	19.5 to 31.5
	MMY-AP3216HT8P	32	64	20.8 to 36.8	20.8 to 33.6
	MMY-AP3416HT8P	34	64	22.1 to 39.1	22.1 to 35.7
	MMY-AP3616HT8P	36	64	23.4 to 41.4	23.4 to 37.8
	MMY-AP3816HT8P	38	64	24.7 to 43.7	24.7 to 39.9
	MMY-AP4016HT8P	40	64	26.0 to 46.0	26.0 to 42.0
	MMY-AP4216HT8P	42	64	27.3 to 48.3	27.3 to 44.1
	MMY-AP4416HT8P	44	64	28.6 to 50.6	28.6 to 46.2
	MMY-AP4616HT8P	46	64	29.9 to 52.9	29.9 to 48.3
High efficiency / Heating capacity priority model	MMY-AP4816HT8P	48	64	31.2 to 55.2	31.2 to 50.4
	MMY-AP5016HT8P	50	64	32.5 to 57.5	32.5 to 52.5
	MMY-AP5216HT8P	52	64	33.8 to 59.8	33.8 to 54.6
	MMY-AP5416HT8P	54	64	35.1 to 62.1	35.1 to 56.7
	MMY-AP5616HT8P	56	64	36.4 to 64.4	36.4 to 58.8
	MMY-AP5816HT8P	58	64	37.7 to 66.7	37.7 to 60.9
	MMY-AP6016HT8P	60	64	39.0 to 69.0	39.0 to 63.0
	MMY-AP2026HT8P	20	45	13.0 to 23.0	13.0 to 21.0
	MMY-AP2226HT8P	22	49	14.3 to 25.3	14.3 to 23.1
	MMY-AP3626HT8P	36	64	23.4 to 41.4	23.4 to 37.8
MMY-AP3826HT8P	38	64	24.7 to 43.7	24.7 to 39.9	
MMY-AP4026HT8P	40	64	26.0 to 46.0	26.0 to 42.0	
MMY-AP4226HT8P	42	64	27.3 to 48.3	27.3 to 44.1	
MMY-AP4426HT8P	44	64	28.6 to 50.6	28.6 to 46.2	
MMY-AP5426HT8P	54	64	35.1 to 62.1	35.1 to 56.7	

■ In case of SHRM-e system

SHRM-e system restrictions

The SHRM-e system can also be connected to a High temperature Hot Water module (H-HWM).

In case of connecting at least one Hot Water Module in SHRM-e system, all of Flow Selector unit type should be Single port type Flow Selector unit (long piping model) or Multi port type Flow Selector unit. Model name of usable Flow Selector unit: RBM-Y1124FE, RBM-Y1804FE, RBM-Y2804FE, RBM-Y1801F6PE, RBM-Y1801F4PE. The Fresh Air intake type and Air to Air Heat Exchanger with DX Coil cannot be connected with the same refrigerant system.

M-HWM connection		Without M-HWM	With M-HWM & H-HWM
Max. No. of combined outdoor units		3 units	3 units
Max. capacity of combined outdoor units		54 HP	54 HP
Max. No. of combined indoor units		64 units (*1)	32 units
Max. capacity of combined indoor units and M-HWM & H-HWM	H2 ≤ 15 m	135%	200%
	H2 > 15 m	105%	125%

M-HWM: Mid temperature Hot Water Module
H-HWM: High temperature Hot Water Module

Restriction on Mid temperature Hot Water Module (M-HWM) connection

Indoor connection capacity (*1)	Total	Standard indoor unit + M-HWM + H-HWM	90 - 200% (*2)(*3)
		Standard indoor unit + M-HWM	90 - 135% (*2)(*3)
	Allowed capacity	Standard indoor unit	50 - 120% (*2)
		M-HWM	0 - 67.5% (*2)(*3)
		H-HWM	0 - 100% (*2)(*3)
		M-HWM + H-HWM	0 - 100% (*2)(*3)
	Standard indoor unit + M-HWM	90 - 135% (*2)(*3)	
Number of combined indoor units, M-HWM and H-HWM	Total	Standard indoor unit + M-HWM + H-HWM	2 - 32
		Standard indoor unit + M-HWM	2 - 32
	Allowed number	Standard indoor unit	2 - 32
		M-HWM	0 - 14
		H-HWM	0 - 12
		M-HWM + H-HWM	0 - 14
	Standard indoor unit + M-HWM	2 - 32	

*1: Ratio of connected total indoor unit capacity to outdoor unit capacity.

*2: Maximum indoor connection capacity is varied depending on the height difference between indoor unit H2, H4, H5.

Combination of indoor units		SHRM-e
Standard indoor unit + M-HWM + H-HWM	H2, H4, H5 ≤ 15 m	Max.200% (Standard indoor unit < 120%)
	H2, H4, H5 > 15 m	Max.125% (Standard indoor unit < 100%)
Standard indoor unit + M-HWM	H2, H4, H5 ≤ 15 m	Max.135% (Standard indoor unit < 120%)
	H2, H4, H5 > 15 m	Max.125% (Standard indoor unit < 100%)

*3: M-HWM and H-HWM connecting capacity should be smaller than standard indoor unit.

NOTE

Design the system that total capacity of simultaneous heating operation is 100% or less. If total capacity of simultaneous heating is over 100%, then each indoor units or Hot Water Module performance is descended.

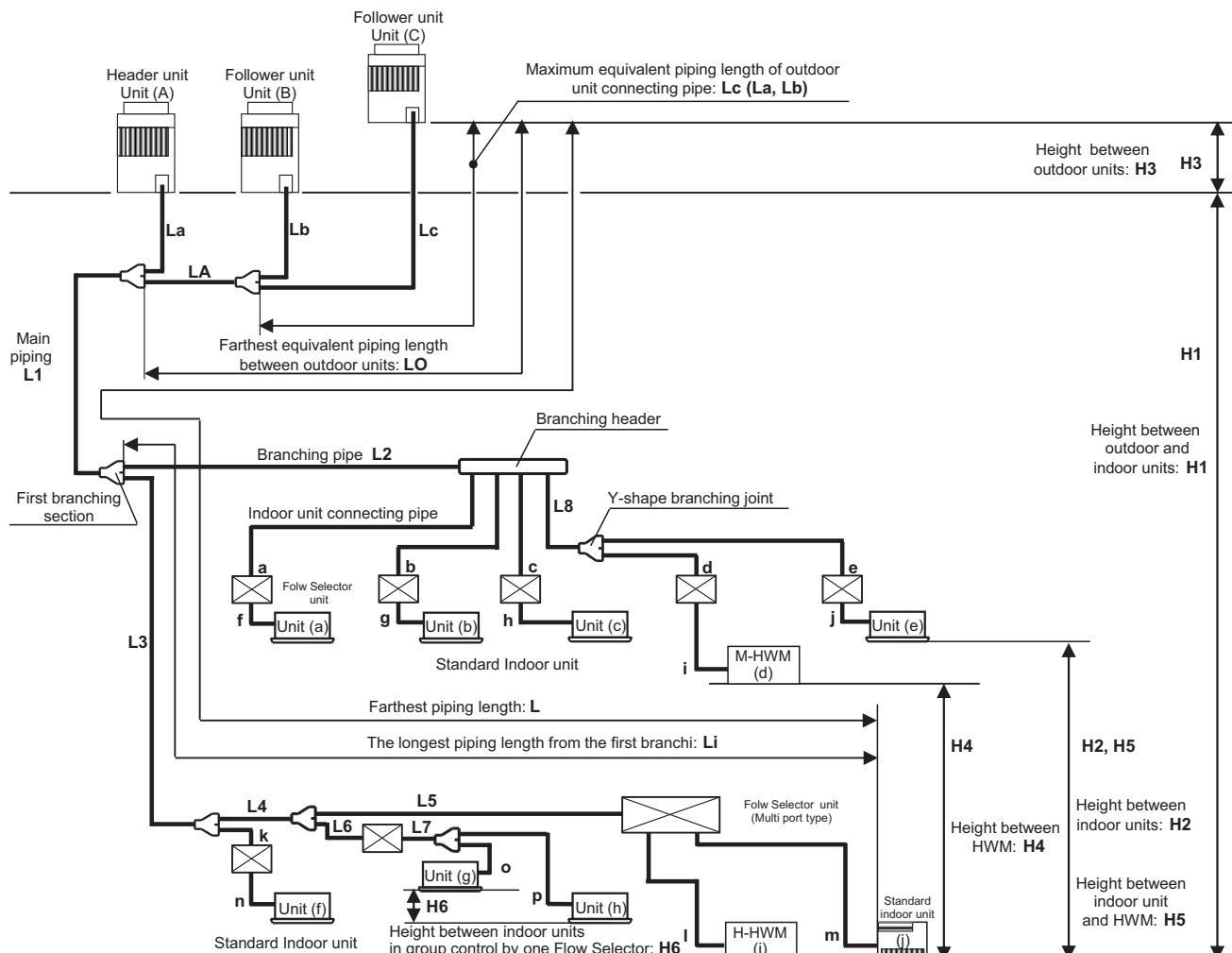

Item	SMMS-e		Pipes			
	Without HWM	With HWM				
Pipe length	Total extension of pipe (liquid pipe, real length)	Less than 34 HP or less	300 m	LA + La + Lb + Lc + L1 + L2 + L3 + L4 + L5 + L6 + L7 + L8 + a + b + c + d + e + f + g + h + i + j + k + l + m + n + o + p		
		34 HP or more	1000 m (*3)		1000 m (*3)	
	Farthest piping length L (*1)(*2)	Equivalent length	200 m (*4)	200 m (*4)	Lc + LA + L1 + L3 + L4 + L5 + m + r	
		Real length	180 m	180 m		
	Maximum equivalent length of main piping (*5)	H2, H4, H5 > 3 m	Equivalent length	100 m	L1	
			Real length	85 m		85 m
		H2, H4, H5 ≤ 3 m	Equivalent length	120 m		120 m
			Real length	100 m		100 m
	Farthest equivalent piping length from the first branch Li (*1)	H2, H4, H5 > 3 m	50 m	50 m	L3 + L4 + L5 + m	
		H2, H4, H5 ≤ 3 m	65 m	65 m		
	Farthest equivalent piping length between outdoor units LO (*1)		15 m	15 m	LA + Lc (LA + Lb)	
	Maximum equivalent length of pipes connected to outdoor units		10 m	10 m	Lc (La, Lb)	
	Maximum real length of terminal branching section to indoor units		30 m	30 m	a + f, b + g, c + h, d + i, e + j	
Maximum real length of between Flow Selector unit and indoor unit	Single port type	15 m	15 m	f, g, h, i, j, n		
	Multi port type	50 m (*6)(*7)	50 m (*6)(*7)	l, m		
Maximum equivalent length between branching section		50 m	50 m	L2, L3, L4, L5, L8		
Height difference	Height between outdoor and indoor units H1 (*8)	Upper outdoor units	70 m (*9)(*13)	70 m (*9)(*13)	—	
		Lower outdoor units	30 m (*10)	30 m (*10)		
	Height between indoor units H2 (*8)	Upper outdoor units	40 m	40 m	—	
		Lower outdoor units (*11)	15 m	15 m		
	Height between HWM H4 (*8)	Upper outdoor units	—	40 m	—	
		Lower outdoor units (*11)	—	15 m		
	Height between indoor units and HWM H5 (*8)	Upper outdoor units	—	40 m	—	
		Lower outdoor units (*11)	—	15 m		
	Height between outdoor units H3 (*12)		5 m	5 m	—	

<In case of connecting single port type Flow Selector unit and a branch of Multi port type Flow Selector unit to the indoor units.>

Maximum equivalent length indoor units in group control by one single port Flow Selector unit Ln	30 m	30 m	L6 + L7 + o, L6 + L7 + p
Maximum real length between Flow Selector unit and indoor unit (*4)	Single port type	15 m	L7 + o, L7 + p
	Multi port type	50 m	50 m
Height difference between indoor units in group control by one Flow Selector unit H6	0.5 m	0.5 m	—

- *1: Furthest outdoor unit from the first branch: (C), furthest indoor unit: (j).
- *2: Total charging refrigerant is 140 kg or less.
- *3: When connecting the multiple indoor units to the single port type Flow Selector unit, wire the indoor unit to the remote controller to the single port type flow selection unit.
- *4: Allowable values for length equivalent to furthest pipe are shown below and they vary according to performance rank of outdoor unit.
22.4 to 56.0: 180 m, 61.5 to 112: 195 m, 120: 200 m.
- *5: As for 44 HP to 54 HP, contact our agent.
- *6: The total piping length in one Flow Selector unit in case of branching to 4: 120 m (p + q + r + s + t + u), In case of branching to 6: 180 m.
- *7: Length of whole pipe should be shorter than 50 m in one branch.
- *8: As for 42 HP to 54 HP, contact our agent.
- *9: If the height difference between indoor units or HWM (H2, H4, H5) exceed 3 m, set 50 m or less.
- *10: 40 m is possible for a system that uses only the Flow Selector unit (multi port type), whose all the indoor units are 3 HP or higher, and working ambient temperature is 0°C or higher.
- *11: When system capacity greater than 28 HP, height difference between indoor units or HWM is limited to 3 m.
If the piping exceeds 3 m with a capacity greater than 28 HP there may be a case of capacity shortage in cooling.
- *12: Ensure that the header unit is installed below all connected follower outdoor unit(s).
Possible product failure may occur if header unit is installed above any follower unit(s).
- *13: Extension up till 90 m is possible with conditions below.
 - Outside Temperature Cooling operation : 10°C to 46°C (Dry-bulb temp.)
 - Heating operation : -5°C to 15.5°C (Wet-bulb temp.)
 - Simultaneous operation : 7°C to 25°C (Dry-bulb temp.)
 - Equivalent length of farthest piping from 1st branching Li < 50 m
 - Real length of main piping L1 < 100 m
 - Height difference between indoor units H2 < 3 m
 - Height difference between FS units < 0.5 m
 - Total capacity of connectable indoor units: 90% - 100%
 - Single CDU, and up to 18 HP
 - Minimum capacity of connectable indoor: unit 4 HP or Larger

NOTE

It is prohibited to connect the standard indoor unit and the HWM to the same Flow Selector unit in SHRM-e system.

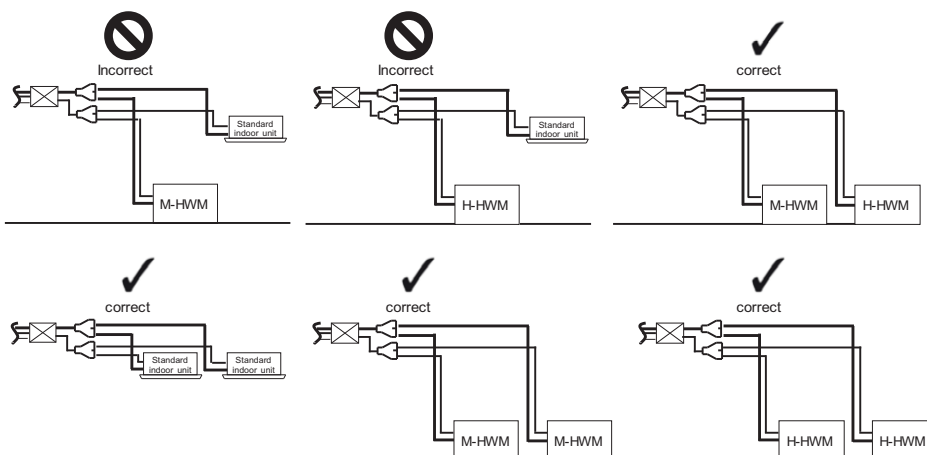

M-HWM: Mid temperature Hot Water Module
H-HWM: High temperature Hot Water Module

Outdoor unit connectable indoor units

▼ Capacity code of Mid temperature Hot water module

The capacity code of the Hot water module is different from the capacity code of the standard indoor unit.

Mid temperature Hot water module		MMW-UP0271LQ-E, -TR	MMW-UP0561LQ-E, -TR
Capacity rank type		027	056
Capacity code	Equivalent to HP (HP)	2.5	5
Equivalent to capacity (kW)		7.1	14.0

▼ Capacity code of standard indoor unit

Capacity rank type	005	007	009	012	015	018	024	027	030	036	048	056	072	096	
Capacity code	0.6	0.8	1	1.25	1.7	2	2.5	3	3.2	4	5	6	8	10	
Equivalent to capacity (kW)		1.7	2.2	2.8	3.6	4.5	5.6	7.1	8.0	9.0	11.2	14.0	16.0	22.4	28.0

SHRM-e	Capacity code of outdoor unit (HP)	Maximum indoor unit quantity	Total capacity code of indoor units (HP) Standard indoor unit + M-HWM + H-HWM		Total capacity code of indoor units (HP) Standard indoor unit + M-HWM	
			H2, H4, H5 ≤ 15 m		H2, H4, H5 > 15 m	
			Total capacity 90 - 200% (Standard indoor unit < 120%)	Total capacity 90 - 125% (Standard indoor unit < 100%)	Total capacity 90 - 135% (Standard indoor unit < 120%)	Total capacity 90 - 125% (Standard indoor unit < 100%)
MMY-MAP0806FT8P	8	18	7.2 to 16.0	7.2 to 10.0	7.2 to 10.8	7.2 to 10.0
MMY-MAP1006FT8P	10	22	9.0 to 20.0	9.0 to 12.5	9.0 to 13.5	9.0 to 12.5
MMY-MAP1206FT8P	12	27	10.8 to 24.0	10.8 to 15.0	10.8 to 16.2	10.8 to 15.0
MMY-MAP1406FT8P	14	31	12.6 to 28.0	12.6 to 17.5	12.6 to 18.9	12.6 to 17.5
MMY-MAP1606FT8P	16	32	14.4 to 32.0	14.4 to 20.0	14.4 to 21.6	14.4 to 20.0
MMY-MAP1806FT8P	18	32	16.2 to 36.0	16.2 to 22.5	16.2 to 24.3	16.2 to 22.5
MMY-MAP2006FT8P	20	32	18.0 to 37.0 (*1)	18.0 to 25.0	18.0 to 25.0 (*2)	18.0 to 25.0
MMY-AP2216FT8P	22	32	19.8 to 44.0	19.8 to 27.5	19.8 to 29.7	19.8 to 27.5
MMY-AP2416FT8P	24	32	21.6 to 48.0	21.6 to 30.0	21.6 to 32.4	21.6 to 30.0
MMY-AP2616FT8P	26	32	23.4 to 52.0	23.4 to 32.5	23.4 to 35.1	23.4 to 32.5
MMY-AP2816FT8P	28	32	25.2 to 56.0	25.2 to 35.0	25.2 to 37.8	25.2 to 35.0
MMY-AP3016FT8P	30	32	27.0 to 60.0	27.0 to 37.5	27.0 to 40.5	27.0 to 37.5
MMY-AP3216FT8P	32	32	28.8 to 64.0	28.8 to 40.0	28.8 to 43.2	28.8 to 40.0
MMY-AP3416FT8P	34	32	30.6 to 68.0	30.6 to 42.5	30.6 to 45.9	30.6 to 42.5
MMY-AP3616FT8P	36	32	32.4 to 72.0	32.4 to 45.0	32.4 to 48.6	32.4 to 45.0
MMY-AP3816FT8P	38	32	34.2 to 72.0 (*1)	34.2 to 47.5	34.2 to 49.4 (*2)	34.2 to 47.5
MMY-AP4016FT8P	40	32	36.0 to 74.0 (*1)	36.0 to 50.0	36.0 to 50.0 (*2)	36.0 to 50.0
MMY-AP4216FT8P	42	32	37.8 to 84.0	37.8 to 52.5	37.8 to 56.7	37.8 to 52.5
MMY-AP4416FT8P	44	32	39.6 to 88.0	39.6 to 55.0	39.6 to 59.4	39.6 to 55.0
MMY-AP4616FT8P	46	32	41.4 to 92.0	41.4 to 57.5	41.4 to 62.1	41.4 to 57.5
MMY-AP4816FT8P	48	32	43.2 to 96.0	43.2 to 60.0	43.2 to 64.8	43.2 to 60.0
MMY-AP5016FT8P	50	32	45.0 to 100	45.0 to 62.5	45.0 to 67.5	45.0 to 62.5
MMY-AP5216FT8P	52	32	46.8 to 104	46.8 to 65.0	46.8 to 70.2	46.8 to 65.0
MMY-AP5416FT8P	54	32	48.6 to 108	48.6 to 67.5	48.6 to 72.9	48.6 to 67.5

M-HWM: Mid temperature Hot water module

H-HWM: High temperature Hot water module

H2, H4, H5: Height difference between indoor unit (Including HWM)

*1: 20 HP and 40 HP: 90 - 185% 38 HP: 90 - 190%

*2: 20 HP and 40 HP: 90 - 125% 38 HP: 90 - 130%

■ In case of SMMS-u system

SMMS-e system restrictions

M-HWM connection		Without M-HWM	With M-HWM
Max. No. of combined outdoor units		5 units	5 units
Max. capacity of combined outdoor units		120 HP	120 HP
Max. No. of combined indoor units		128 units	128 units
Max. capacity of combined indoor units and M-HWM	H2 ≤ 15 m	Combination outdoor units	115%
		Single outdoor unit 200%	
	H2 > 15 m	105%	105%

M-HWM: Mid temperature Hot Water Module

Restriction on Mid temperature Hot Water Module (M-HWM) connection

Indoor connection capacity (*1)	Total	Standard indoor unit + M-HWM	65 - 115% (*1)
	Allowed capacity	Standard indoor unit	50 - 115%
Number of combined indoor units and M-HWM	Total	Standard indoor unit + M-HWM	2 - 128
		Standard indoor unit	2 - 128
	Allowed number	M-HWM	0 - 14

*1: Ratio of connected total indoor unit capacity to outdoor unit capacity.

*2: M-HWM connecting capacity should be smaller than standard indoor unit.

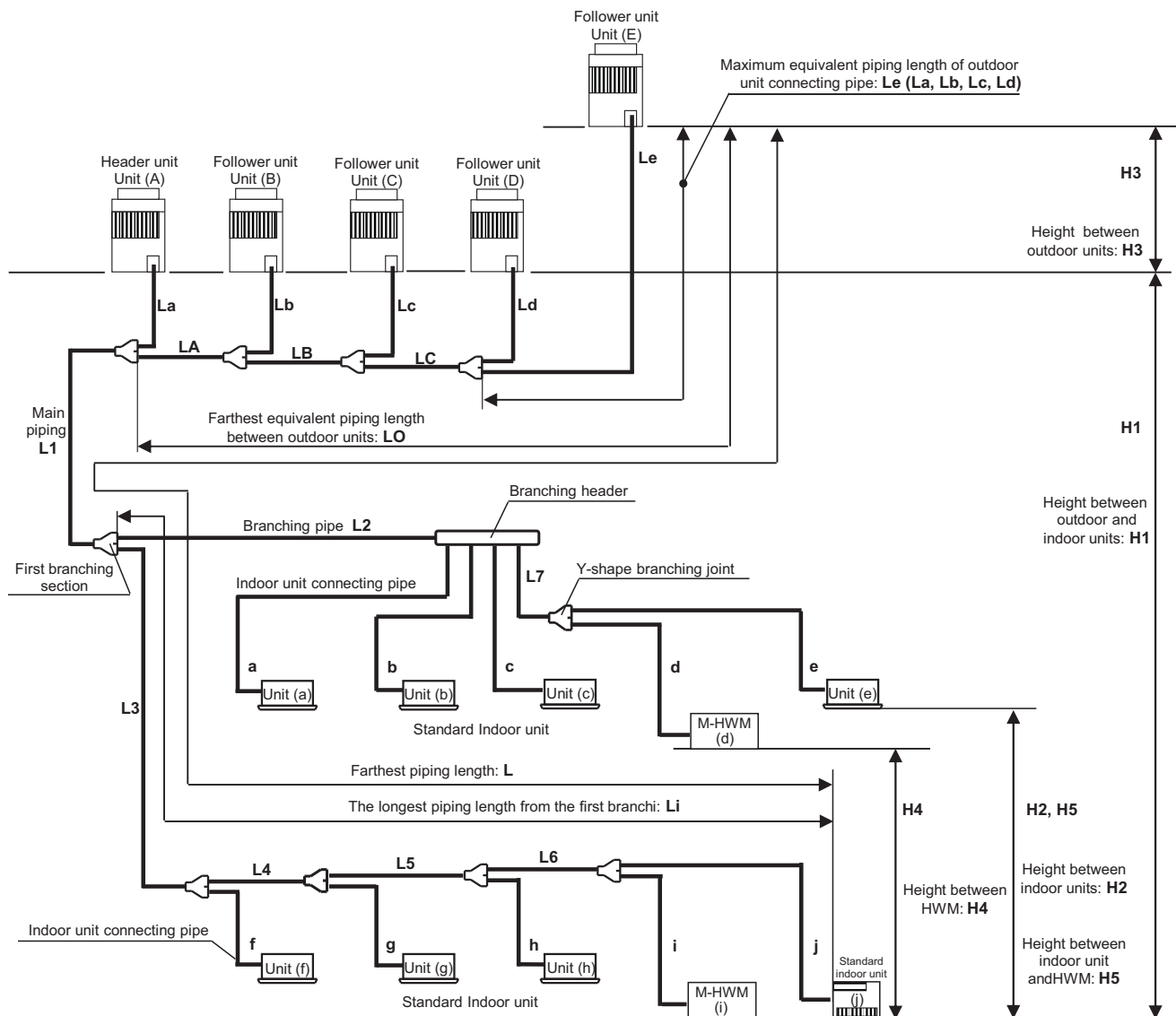

Item	SMMS-u		Pipes		
	Without M-HWM	With M-HWM			
Pipe length	Total extension of pipe (liquid pipe, real length)	Single outdoor unit system Multiple outdoor unit system	500 m 1200 m (*2) 1200 m (*2)	LA + LB + LC + La + Lb + Lc + Ld + Le + L1 + L2 + L3 + L4 + L5 + L6 + L7 + a + b + c + d + e + f + g + h + i + j	
	Farthest piping length L (*1)	Equivalent length	250 m	250 m	Le + LA + LB + LC + L1 + L3 + L4 + L5 + L6 + j
		Real length	210 m	210 m	
	Maximum equivalent length of main piping L1	Equivalent length	120 m (*3)	120 m (*3)	L1
		Real length	100 m (*3)	100 m (*3)	
	Farthest equivalent piping length from the first branch Li (*1)	H1 > 3 m	65 m	65 m	L3 + L4 + L5 + L6 + j
		H1 ≤ 3 m	90 m	90 m	
	Farthest equivalent piping length between outdoor units LO (*1)		40 m	40 m	LA + LB + LC + Le (LA + LB + LC + Ld, LA + LB + Lc, LA + Lb)
	Maximum equivalent length of pipes connected to outdoor units		10 m	10 m	Le (La, Lb, Lc, Ld)
	Maximum real length of indoor unit connecting piping		30 m	30 m	a, b, c, d, e, f, g, h, i, j
Maximum equivalent length between branches		50 m	50 m	L2, L3, L4, L5, L6, L7	
Height difference	Height between outdoor and indoor units H1	Upper outdoor units	70 m (*4)(*7)	70 m (*4)	—
		Lower outdoor units	40 m (*5)(*8)	40 m (*5)	
	Height between indoor units H2	Upper outdoor units	40 m (*9)	3 m (*6 40 m)	—
		Lower outdoor units	40 m (*9)	10 m (*6 40 m)	
	Height between HWM H4	Upper outdoor units	—	3 m	—
		Lower outdoor units	—	—	
	Height between indoor units and HWM H5	Upper outdoor units	—	3 m (*6 40 m)	—
		Lower outdoor units	—	10 m (*6 40 m)	
	Height between outdoor units H3		5 m	5 m	—

- *1: Furthest outdoor unit from the first branch: (E), furthest indoor unit: (j).
- *2: Total charging refrigerant is 140 kg or less.
- *3: If the max. combined outdoor unit capacity is 54 HP or more, than max. equivalent length is 70 m or less (real length is 50 m or less).
- *4: If the height difference between indoor units (H2) exceeds 3 m, set 50 m or less.
- *5: If the height difference between indoor units (H2) exceeds 3 m, set 30 m or less.
- *6: If the Hot Water Module and indoor units are not operating at the same time.
- *7: Extension up to 110 m is possible with conditions below:
 - Independent outdoor unit system
 - Capacity of combined indoor units: 105% or less
 - Liquid side has been increased one size from the standard size
 - The height difference between indoor units (H2) is 3 m or less
- *8: Extension up to 110 m is possible with conditions below:
 - System combining two or more outdoor unit
 - Minimum capacity of connecting indoor unit is more than 3 HP
 - The height difference between indoor units (H2) is 3 m or less
- *9: If the connected ratio of indoor units to outdoor units is more than 105%, set 15 m or less.

Outdoor unit connectable indoor units

▼ Capacity code of Mid temperature Hot water module
The capacity code of the Hot water module is different from the capacity code of the standard indoor unit.

Hot water module	Mid temperature	
	MMW-UP0271LQ-E	MMW-UP0561LQ-E
Capacity rank type	027	056
Capacity code	2.5	5
Equivalent to capacity	(kW) 7.1	14.0

▼ Capacity code of standard indoor unit

Capacity rank type	005	007	009	012	015	018	024	027	030	036	048	056	072	096
Capacity code	0.6	0.8	1	1.25	1.7	2	2.5	3	3.2	4	5	6	8	10
Equivalent to capacity	(HP) 1.7	2.2	2.8	3.6	4.5	5.6	7.1	8.0	9.0	11.2	14.0	16.0	22.4	28.0

SMMS-u	Capacity code of outdoor unit (HP)	Max. No. of combined indoor units and M-HWM	Total capacity code of indoor units (HP) Standard indoor unit + M-HWM	
			H2, H4, H5 ≤ 15 m	H2, H4, H5 > 15 m
			Total capacity 65 - 115%	Total capacity 65 - 105%
MMY-MUP0801HT8P	8	18	5.2 to 9.2	5.2 to 8.4
MMY-MUP1001HT8P	10	22	6.5 to 11.5	6.5 to 10.5
MMY-MUP1201HT8P	12	27	7.8 to 13.8	7.8 to 12.6
MMY-MUP1401HT8P	14	31	9.1 to 16.1	9.1 to 14.7
MMY-MUP1601HT8P	16	36	10.4 to 18.4	10.4 to 16.8
MMY-MUP1801HT8P	18	40	11.7 to 20.7	11.7 to 18.9
MMY-MUP2001HT8P	20	45	13.0 to 23.0	13.0 to 21.0
MMY-MUP2201HT8P	22	49	14.3 to 25.3	14.3 to 23.1
MMY-MUP2401HT8P	24	54	15.6 to 27.6	15.6 to 25.2
MMY-UP2611HT8P	26	58	16.9 to 29.9	16.9 to 27.3
MMY-UP2811HT8P	28	63	18.2 to 32.2	18.2 to 29.4
MMY-UP3011HT8P	30	64	19.5 to 34.5	19.5 to 31.5
MMY-UP3211HT8P	32	65	20.8 to 36.8	20.8 to 33.6
MMY-UP3411HT8P	34	66	22.1 to 39.1	22.1 to 35.7
MMY-UP3611HT8P	36	67	23.4 to 41.4	23.4 to 37.8
MMY-UP3811HT8P	38	68	24.7 to 43.7	24.7 to 39.9
MMY-UP4011HT8P	40	69	26.0 to 46.0	26.0 to 42.0
MMY-UP4211HT8P	42	70	27.3 to 48.3	27.3 to 44.1
MMY-UP4411HT8P	44	71	28.6 to 50.6	28.6 to 46.2
MMY-UP4611HT8P	46	72	29.9 to 52.9	29.9 to 48.3

M-HWM: Mid temperature Hot water module
H2, H4, H5: Height difference between indoor unit (Including HWM)

SMMS-u	Capacity code of outdoor unit (HP)	Max. No. of combined indoor units and M-HWM	Total capacity code of indoor units (HP) Standard indoor unit + M-HWM	
			H2, H4, H5 ≤ 15 m	H2, H4, H5 > 15 m
			Total capacity 65 - 115%	Total capacity 65 - 105%
MMY-UP4811HT8P	48	73	31.2 to 55.2	31.2 to 50.4
MMY-UP5011HT8P	50	74	32.5 to 57.5	32.5 to 52.5
MMY-UP5211HT8P	52	75	33.8 to 59.8	33.8 to 54.6
MMY-UP5411HT8P	54	76	35.1 to 62.1	35.1 to 56.7
MMY-UP5611HT8P	56	77	36.4 to 64.4	36.4 to 58.8
MMY-UP5811HT8P	58	78	37.7 to 66.7	37.7 to 60.9
MMY-UP6011HT8P	60	79	39.0 to 69.0	39.0 to 63.0
MMY-UP6211HT8P	62	80	40.3 to 71.3	40.3 to 65.1
MMY-UP6411HT8P	64	81	41.6 to 73.6	41.6 to 67.2
MMY-UP6611HT8P	66	82	42.9 to 75.9	42.9 to 69.3
MMY-UP6811HT8P	68	83	44.2 to 78.2	44.2 to 71.4
MMY-UP7011HT8P	70	84	45.5 to 80.5	45.5 to 73.5
MMY-UP7211HT8P	72	85	46.8 to 82.8	46.8 to 75.6
MMY-UP7411HT8P	74	86	48.1 to 85.1	48.1 to 77.7
MMY-UP7611HT8P	76	87	49.4 to 87.4	49.4 to 79.8
MMY-UP7811HT8P	78	88	50.7 to 89.7	50.7 to 81.9
MMY-UP8011HT8P	80	90	52.0 to 92.0	52.0 to 84.0
MMY-UP8211HT8P	82	92	53.3 to 94.3	53.3 to 86.1
MMY-UP8411HT8P	84	94	54.6 to 96.6	54.6 to 88.2
MMY-UP8611HT8P	86	96	55.9 to 98.9	55.9 to 90.3
MMY-UP8811HT8P	88	98	57.2 to 101.2	57.2 to 92.4
MMY-UP9011HT8P	90	100	58.5 to 103.5	58.5 to 94.5
MMY-UP9211HT8P	92	102	59.8 to 105.8	59.8 to 96.6
MMY-UP9411HT8P	94	104	61.1 to 108.1	61.1 to 98.7
MMY-UP9611HT8P	96	106	62.4 to 110.4	62.4 to 100.8
MMY-UP9811HT8P	98	108	63.7 to 112.7	63.7 to 102.9
MMY-UP10011HT8P	100	110	65.0 to 115.0	65.0 to 105.0
MMY-UP10211HT8P	102	112	66.3 to 117.3	66.3 to 107.1
MMY-UP10411HT8P	104	114	67.6 to 119.6	67.6 to 109.2
MMY-UP10611HT8P	106	116	68.9 to 121.9	68.9 to 111.3
MMY-UP10811HT8P	108	118	70.2 to 124.2	70.2 to 113.4
MMY-UP11011HT8P	110	120	71.5 to 126.5	71.5 to 115.5
MMY-UP11211HT8P	112	122	72.8 to 128.8	72.8 to 117.6
MMY-UP11411HT8P	114	124	74.1 to 131.1	74.1 to 119.7
MMY-UP11611HT8P	116	126	75.4 to 133.4	75.4 to 121.8
MMY-UP11811HT8P	118	128	76.7 to 135.7	76.7 to 123.9
MMY-UP12011HT8P	120	128	78.0 to 138.0	78.0 to 126.0

M-HWM: Mid temperature Hot water module
H2, H4, H5: Height difference between indoor unit (Including HWM)

■ In case of SHRM-A system

SHRM-A system restrictions

Mid temperature Hot Water Module (M-HWM) is connectable to SHRM-A.

High temperature Hot Water module (H-HWM) cannot connect to SHRM-A.

The Fresh Air intake type and Air to Air Heat Exchanger with DX Coil cannot be connected with the same refrigerant system.

M-HWM connection		Without M-HWM	With M-HWM
Max. No. of combined outdoor units		1 unit	1 unit
Max. capacity of combined outdoor units		24 HP	24 HP
Max. No. of combined indoor units		54 units	54 units
Max. capacity of combined indoor units and M-HWM	H2 ≤ 15 m	200%	135%
	H2 > 15 m	105%	125%

Restriction on Mid temperature Hot Water Module (M-HWM) connection

Indoor connection capacity (*1)	Total	Standard indoor unit + M-HWM	70 - 135% (*2)(*3)
	Allowed capacity	Standard indoor unit M-HWM	50 - 120% (*2) 0 - 67.5% (*2)(*3)
Number of combined indoor units	Total	Standard indoor unit + M-HWM	2 - 54
	Allowed number	Standard indoor unit M-HWM	2 - 54 0 - 6

*1: Ratio of connected total indoor unit capability to outdoor unit capability.

*2: Maximum indoor connection capacity is varied depending on the height difference between indoor unit H2, H4, H5.

Combination of indoor units		
Standard indoor unit + M-HWM	H2, H4, H5 ≤ 15 m	Max. 135% (Standard indoor unit < 120%)
	H2, H4, H5 > 15 m	Max. 125% (Standard indoor unit < 100%)

*3: M-HWM connecting capacity should be smaller than standard unit.

NOTE

Design the system that total capacity of simultaneous heating operation is 100% or less. If total capacity of simultaneous heating is over 100%, then each indoor units or Hot Water Module performance is descended.

■ Heat recovery restrictions

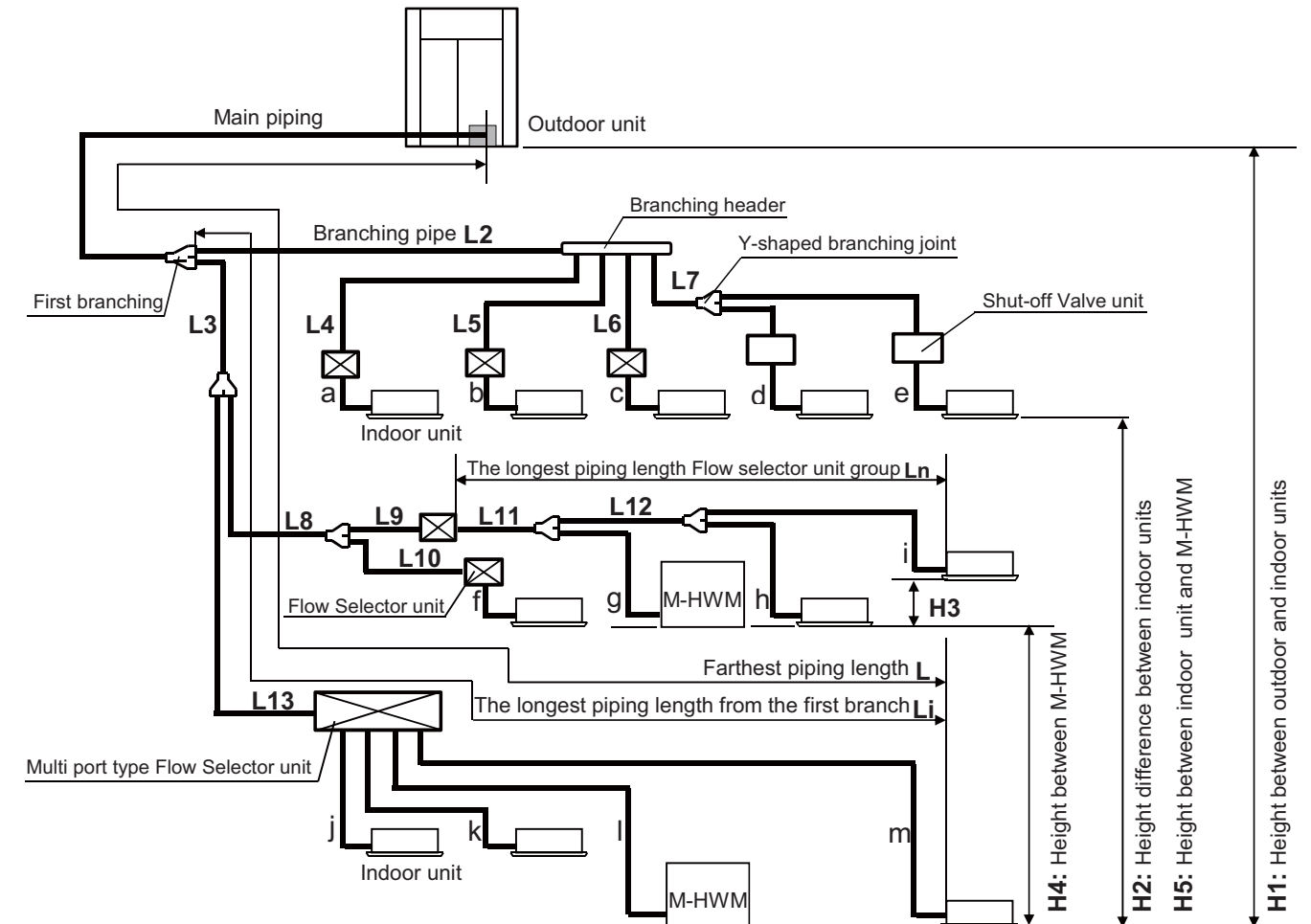

Item		SHRM-A		Pipes		
		Without Value	With Value			
Pipe length	Total extension of pipe (liquid pipe, real length)		500 m (*1)	500 m (*1)	L1 + L2 + L3 + L4 + L5 + L6 + L7 + L8 + L9 + L10 + L11 + L12 + L13 + a + b + c + d + e + f + g + h + i + j + k + l + m	
	Farthest piping length L	Equivalent length	190 m	190 m	L1 + L3 + L13 + m	
		Real length	165 m	165 m		
	Max. equivalent length of Main piping L1	Equivalent length	125 m	125 m	L1	
		Real length	100 m	100 m		
	Equivalent length of farthest piping from 1 st branching Li	H1 > 3 m	50 m	50 m	L3 + L13 + m	
		H1 ≤ 3 m	65 m	65 m		
	Max. real length of piping from the end branch to the indoor unit		50 m	50 m	L4 + a, L5 + b, L6 + c, d, e, L10 + f, g, h, i, j, k, l, m	
	Max. equivalent length between branches		50 m	50 m	L2, L3, L4, L5, L6, L7, L8, L9, L10, L11, L12, L13	
	Max. real length of piping from Flow selector unit to the indoor unit Ln		50 m	50 m	L11 + g, L11 + L12 + h, L11 + L12 + i	
The total piping length in one Multi port type Flow Selector unit	4 branches	Max	120 m	120 m	j + k + l + m	
	8 or 12 branches (*3)	Max	180 m	180 m		
Difference in height	Height between outdoor and indoor units H1	Upper outdoor unit	H2 > 3 m	50 m	50 m	—
			H2 ≤ 3 m	70 m	70 m	
		Lower outdoor unit		40 m	40 m	
	Height between indoor units H2	Upper outdoor unit		40 m	40 m	—
	Height between M-HWM H4	Lower outdoor unit		15 m / 30 m	15 m / 30 m	
	Height between indoor units and H-WMH H5			(*4)	(*4)	
Height difference between indoor units connected to the same Flow selector unit H3			15 m	15 m	—	

*1: The total amount of system refrigerant should be 63.8 kg or less.

*2: Extension up till 90 m is possible with conditions below:

- Connected ratio of indoor units to outdoor units is below 105%.
- Liquid side has been increased 1 size from standard size.
- Change the connection method of the indoor unit from flare connection to welding connection.

*3: When using a Multi port type Flow Selector unit, be sure to set the piping length between the indoor and the Flow Selector unit at least 10 m.

If a piping length of 10 m or longer is not secured, refrigerant noise generated from the Multi port type Flow Selector unit may propagate to the indoor unit.

*4: If H2, H4 and H5 exceed 15 m, it is prohibited to reduce the diameter of the liquid pipe.

NOTE

It is prohibited to connect the standard indoor unit and the M-HWM to same Flow Selector unit in SHRM-A system.

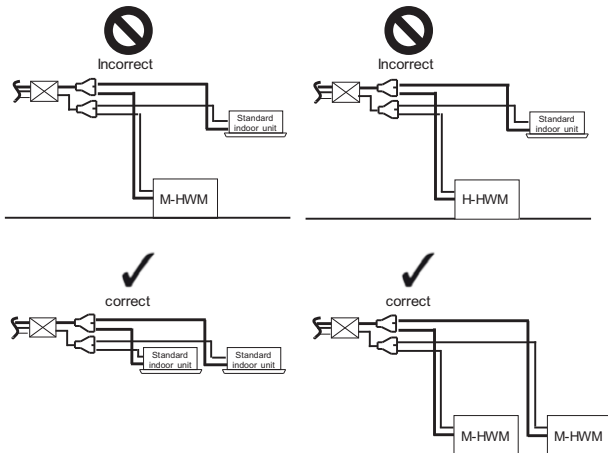

M-HWM: Mid temperature Hot Water Module

■ Heat pump restrictions

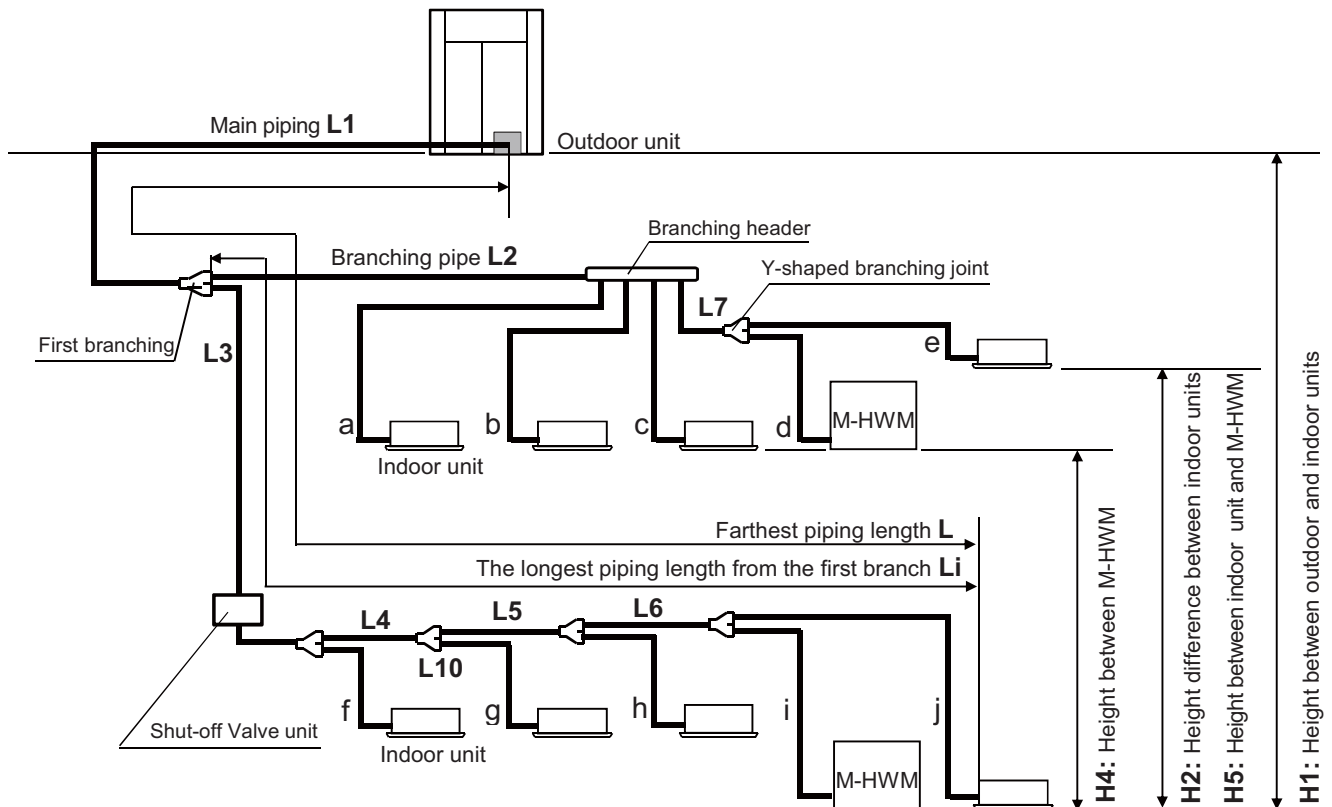

Item		SHRM-A		Pipes	
		Without Value	With Value		
Pipe length	Total extension of pipe (liquid pipe, real length)	500 m (*1)	500 m (*1)	$L1 + L2 + L3 + L4 + L5 + L6 + L7 + a + b + c + d + e + f + g + h + i + j$	
	Farthest piping length L	Equivalent length	215 m	215 m	$L1 + L3 + L4 + L5 + L6 + j$
		Real length	190 m	190 m	
	Max. equivalent length of Main piping L1	Equivalent length	125 m	125 m	L1
		Real length	100 m	100 m	
	Equivalent length of farthest piping from 1st branching Li	H1 > 3 m	65 m	65 m	$L3 + L4 + L5 + L6 + j$
		H1 ≤ 3 m	90 m	90 m	
Max. real length of indoor unit connecting piping		50 m	50 m	a, b, c, d, e, f, g, h, i, j	
Max. equivalent length between branches		50 m	50 m	L2, L3, L4, L5, L6, L7	
Difference in height	Height difference between outdoor and indoor unit H1	Upper outdoor unit	H2 > 3 m	50 m	—
			H2 ≤ 3 m	70 m	
	Lower outdoor unit		40 m	40 m	—
			40 m	40 m	
	Height between indoor units H2	Upper outdoor unit	40 m	40 m	—
Height between M-HWM H4	Lower outdoor unit	40 m	15 m / 30 m (*3)		
Height between indoor units and H-WMH H5					

*1: The total amount of system refrigerant should be 63.8 kg or less.

*2: Extension up till 90 m is possible with conditions below:

- Connected ratio of indoor units to outdoor units is below 105%
- Liquid side has been increased 1 size from standard size
- Change the connection method of the indoor unit from flare connection to welding connection.

*3: If H2, H4 and H5 exceed 15 m, it is prohibited to reduce the diameter of the liquid pipe.

Outdoor unit connectable indoor units

▼ Capacity code of Mid temperature Hot water module

The capacity code of the Hot water module is different from the capacity code of the standard indoor unit.

Mid temperature Hot water module		MMW-UP0271Q-E	MMW-UP0561Q-E
Capacity rank type		027	056
Capacity code	Equivalent to HP (HP)	2.5	5
Equivalent to capacity (kW)		7.1	14.0

▼ Capacity code of standard indoor unit

Capacity rank type		005	007	009	012	015	018	024	027	030	036	048	056	072	096
Capacity code	Equivalent to HP (HP)	0.6	0.8	1	1.25	1.7	2	2.5	3	3.2	4	5	6	8	10
Equivalent to capacity (kW)		1.7	2.2	2.8	3.6	4.5	5.6	7.1	8.0	9.0	11.2	14.0	16.0	22.4	28.0

SMMS-u	Capacity code of outdoor unit (HP)	Maximum indoor unit quantity	Total capacity code of indoor units (HP) Standard indoor unit + M-HWM	
			H2, H4, H5 ≤ 15 m	H2, H4, H5 > 15 m
			Total capacity 70 - 135% (Standard indoor unit < 120%)	Total capacity 70 - 125% (Standard indoor unit < 100%)
MMY-SUG0801MT8P	8	18	5.6 to 10.8	5.6 to 10.0
MMY-SUG1001MT8P	10	22	7.0 to 13.5	7.0 to 12.5
MMY-SUG1201MT8P	12	27	8.4 to 16.2	8.4 to 15.0
MMY-SUG1401MT8P	14	31	9.8 to 18.9	9.8 to 17.5
MMY-SUG1601MT8P	16	36	11.2 to 21.6	11.2 to 20.0
MMY-SUG1801MT8P	18	40	12.6 to 24.3	12.6 to 22.5
MMY-SUG2001MT8P	20	45	14.0 to 27.0	14.0 to 25.0
MMY-SUG2201MT8P	22	49	15.4 to 29.7	15.4 to 27.5
MMY-SUG2401MT8P	24	54	16.8 to 32.4	16.8 to 30.0

M-HWM: Mid temperature Hot water module

H2, H4, H5: Height difference between indoor unit (Including HWM)

■ In case of MiNi SMMS-e (8-10HP) system

M-HWM: Mid temperature Hot Water Module

No.	Item		M-HWM connection	Without M-HWM connection	
1	System capacity		Depending on the outdoor unit to be connected		
2	Indoor connection capacity		Max.	130% (*1) (Excluding M-HWM) 200% (Including M-HWM)	
			Min.	80% (*1) (Excluding M-HWM)	
3	M-HWM connection capacity per refrigerant system		Max.	100% or less	
4	Height difference	Height between outdoor and indoor units (including M-HWM) H1	Upper outdoor units (*2)	(*2)	
			Lower outdoor units (*2)	(*2)	
		Height between indoor units (including M-HWM) H2, H3, H4	Indoor - Indoor H2	Upper outdoor units	10 m
				Lower outdoor units	10 m
	See Figure 1	Indoor - M-HWM H4	Upper outdoor units	10 m	
			Lower outdoor units	10 m	
		M-HWM - M-HWM H3	Upper outdoor units	10 m	
			Lower outdoor units	10 m	

*1: For more information, please read the Installation Manual provided with the outdoor unit. (Total capacity code of connectable indoor units)

*2: For more information, please read the Installation Manual provided with the outdoor unit. (Where H1 is indicated)

*3: Please read the Installation Manual provided with the outdoor unit. (Where H2 is indicated)

▼ Capacity code of outdoor unit, Maximum indoor unit quantity and total capacity code of indoor unit

MiNi SMMS-e	Capacity code of outdoor unit (HP)	Maximum indoor unit quantity	Total capacity code of indoor units (HP) Standard indoor unit + M-HWM Total capacity 80 - 200%
MCY-MHP0806HS8*	8	12	6.4 to 16.0
MCY-MHP1006HS8*	10	16	8.0 to 20.0

▼ Capacity code of Mid temperature Hot water module

The capacity code of the Hot water module is different from the capacity code of the standard indoor unit.

Mid temperature Hot water module		MMW-UP0271LQ-E	MMW-UP0561LQ-E
Capacity rank type		027	056
Capacity code	Equivalent to HP (HP)	2.5	5
Equivalent to capacity (kW)		7.1	14.0

▼ Capacity code of standard indoor unit

Capacity rank type		005	007	009	012	015	018	024	027
Capacity code	Equivalent to HP (HP)	0.6	0.8	1	1.25	1.7	2	2.5	3
Equivalent to capacity (kW)		1.7	2.2	2.8	3.6	4.5	5.6	7.1	8.0

Capacity rank type		030	036	048	056
Capacity code	Equivalent to HP (HP)	3.2	4	5	6
Equivalent to capacity (kW)		9.0	11.2	14.0	16.0

▼ Figure 1
 <Upper outdoor units>

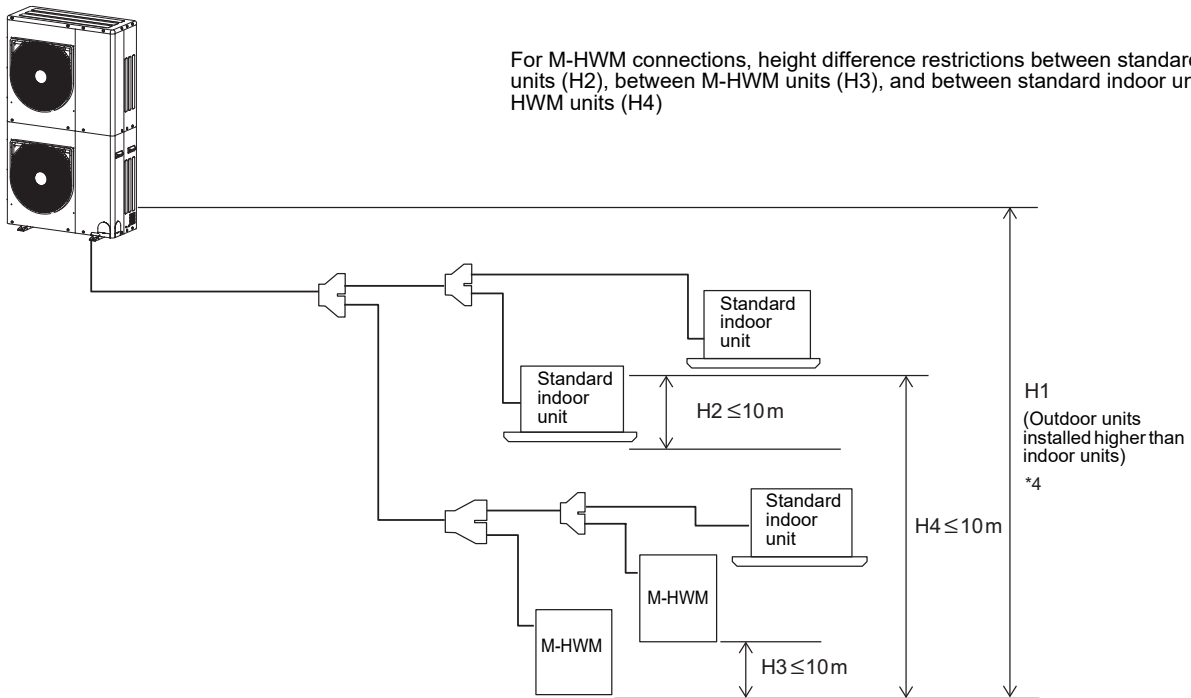

*4 : Please read the Installation Manual provided with the outdoor unit. (Where H1 is indicated)
 H1: Height difference between outdoor units and indoor units (including M-HWM)
 H2: Height difference between standard indoor units
 H3: Height difference between M-HWMs
 H4: Height difference between standard indoor units and M-HWMs

M-HWM: Mid temperature Hot Water Module

<Lower outdoor units >

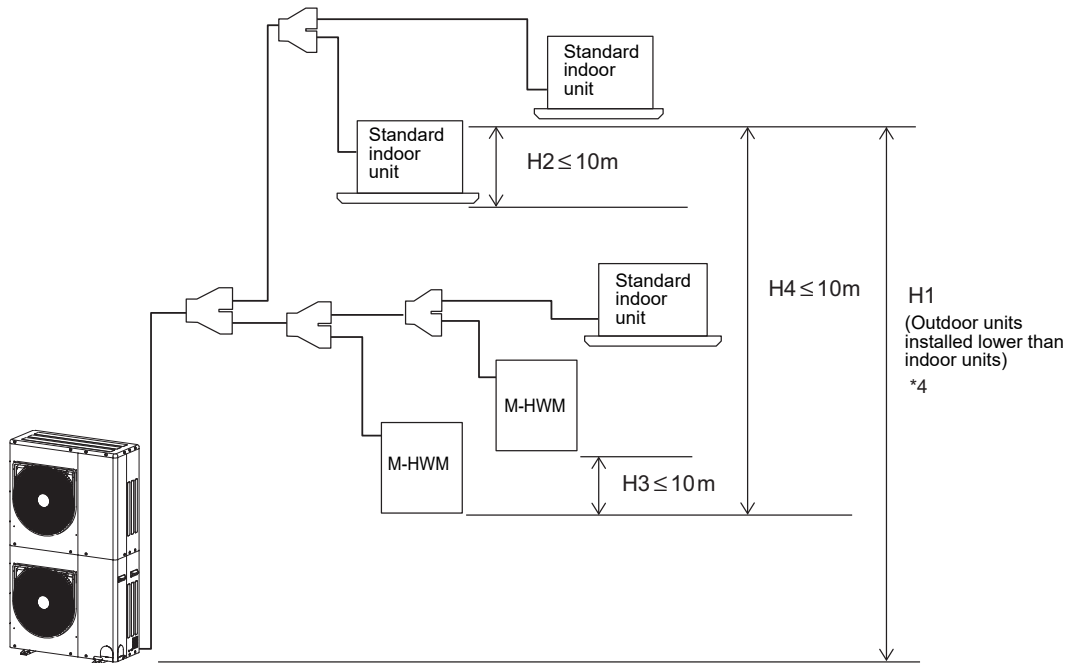

*4 : Please read the Installation Manual provided with the outdoor unit. (Where H1 is indicated)
 H1: Height difference between outdoor units and indoor units (including M-HWM)
 H2: Height difference between standard indoor units
 H3: Height difference between M-HWMs
 H4: Height difference between standard indoor units and M-HWMs

2. Specifications

Model			MMW-UP0271LQ-E/TR	MMW-UP0561LQ-E/TR	
Heating capacity (*1)		(kW)	8.0	16.0	
Electrical characteristics	Power supply (*2)		1 phase 50 Hz 220 - 240 V		
	Running current		0.08	0.08	
	Power consumption		14	14	
Appearance			Zinc hot dipping steel plate		
Dimension	Unit	Height	(mm)	580	
		Width (leg included)	(mm)	400 (467)	
		Depth	(mm)	250	
	Packed (*3)	Height	(mm)	357	
		Width	(mm)	638	
		Depth	(mm)	833	
Weight	Unit	(kg)	17.8	20.3	
	Packed	(kg)	23	25	
Design Pressure	Refrigerant side	(MPa)	4.15	4.15	
	Water side	(MPa)	1.0	1.0	
Heat exchanger			Plate type heat exchanger		
Heat-insulating material			Polyethylene foam + Polyurethane foam		
Water flow rate	Standard	(L/min)	22.9	45.8	
	Min.	(L/min)	19.5	38.9	
Water pressure loss (at standard water flow rate)		(kPa)	40.5	44.2	
Controller			Remote controller		
Operation range	Ambient	indoor	(°CDB)	5 - 32	
		Allowable dew point	(°CDB)	23 or less	
			RH(%)	30 - 85	
		Outdoor (at heating) SMMS-e	(°CDB)	-20 - 21	
			(°CWB)	-20 - 19	
		Outdoor (at heating) SHRM-e	(°CDB)	-25 - 40	
			(°CWB)	-25 - 28	
		Outdoor (at heating) SMMS-u	(°CDB)	-25 - 21	
			(°CWB)	-25 - 19	
		Outdoor (at heating) SHRM Advance (*5)	(°CDB)	-25 - 21	
	(°CWB)		-25 - 19		
	Outdoor (at heating) MiNi SMMS-e	(°CDB)	-20 - 21		
(°CWB)		-20 - 15			
Water inlet side	(°C)	15 - 45			
Water outlet side	(°C)	25 - 50			
Water filter			Strainer with Mesh 30 to 40 (procured locally)		
Connecting pipe	Water pipe	Inlet		R1 - 1/4	
		Outlet		R1 - 1/4	
	Refrigerant pipe	Gas pipe	(mm)	φ15.9 flare connection	
		Liquid pipe	(mm)	φ9.5 flare connection	
Drain pipe			R1		
Sound pressure level		(dB(A))	25	27	
Installation place			Indoor		

*1: Rated conditions: entering condenser water temp. 30°C leaving condenser water temp. 35°C Outdoor air temp. 7°CDB / 6°CWB

The standard piping means that main pipe length is 5 m, branching pipe length is 2.5 m of branch piping connected with a 0 meter height.

*2: The source voltage must not fluctuate more than ±10%.

*3: The unit is packed in a sideways state.

*4: This specification is value as of December, 2020, please note that specification is subject to change without notice.

*5: If the outside temperature is 25°CDB (19°CWB) or higher, HWM unit will be thermo-off unless at least one indoor unit is in cooling operation.

Remote controller (TCC-LINK)

RBC-AMT32E, RBC-AMS41E, RBC-AMS55E-ES/EN, RBC-AS41E, RBC-ASC11E/TR, RBC-ASC21E, TCB-EXS21TLE

Remote controller (TU2C-LINK)

RBC-ASCU11-E/TR, RBC-AMTU31-E/TR, RBC-AMSU51-ES/EN

3. Dimensional drawing

MMW-UP0271LQ-E, MMW-UP0271LQ-TR, MMW-UP0561LQ-E, MMW-UP0561LQ-TR

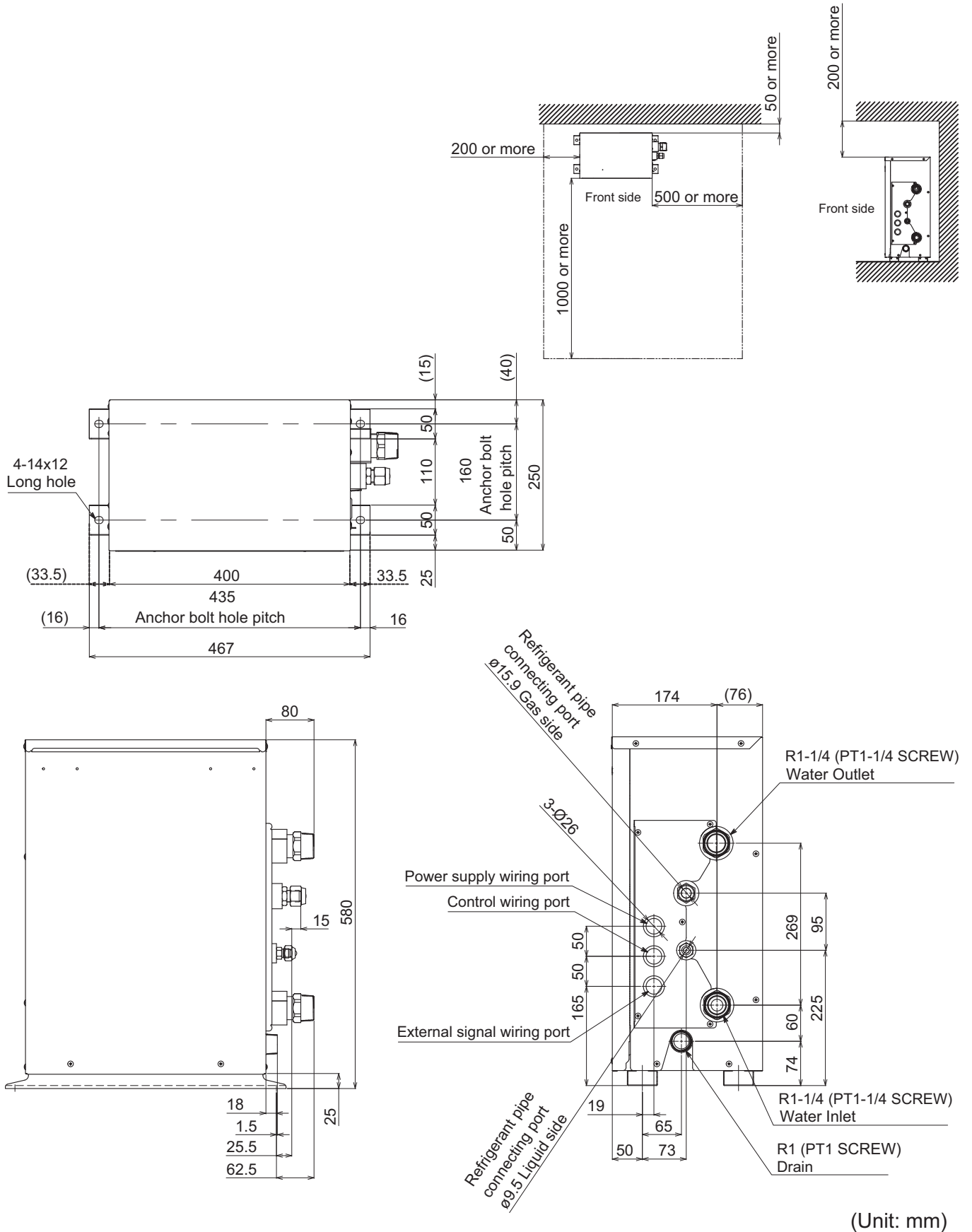

(Unit: mm)

4. Center of gravity

MMW-UP0271LQ-E, MMW-UP0271LQ-TR, MMW-UP0561LQ-E, MMW-UP0561LQ-TR

Default

Model type	X (mm)	Y (mm)	Z (mm)	Weight (kg)
027	203	80	265	17.8
056	213	90	265	20.3

Operating

Model type	X (mm)	Y (mm)	Z (mm)	Weight (kg)
027	206	81	265	18.4
056	218	91	265	21.6

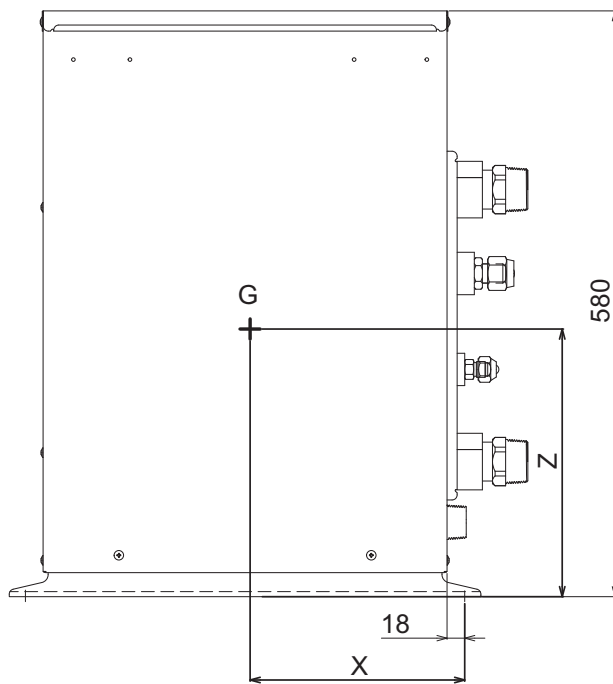
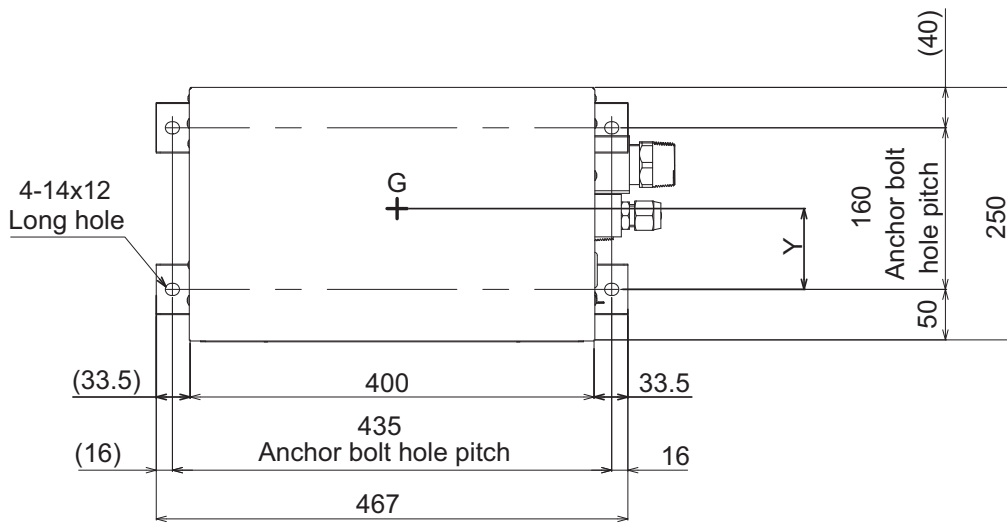

(Unit: mm)

5. Refrigerant cycle diagram

MMW-UP0271LQ-E, MMW-UP0271LQ-TR, MMW-UP0561LQ-E, MMW-UP0561LQ-TR

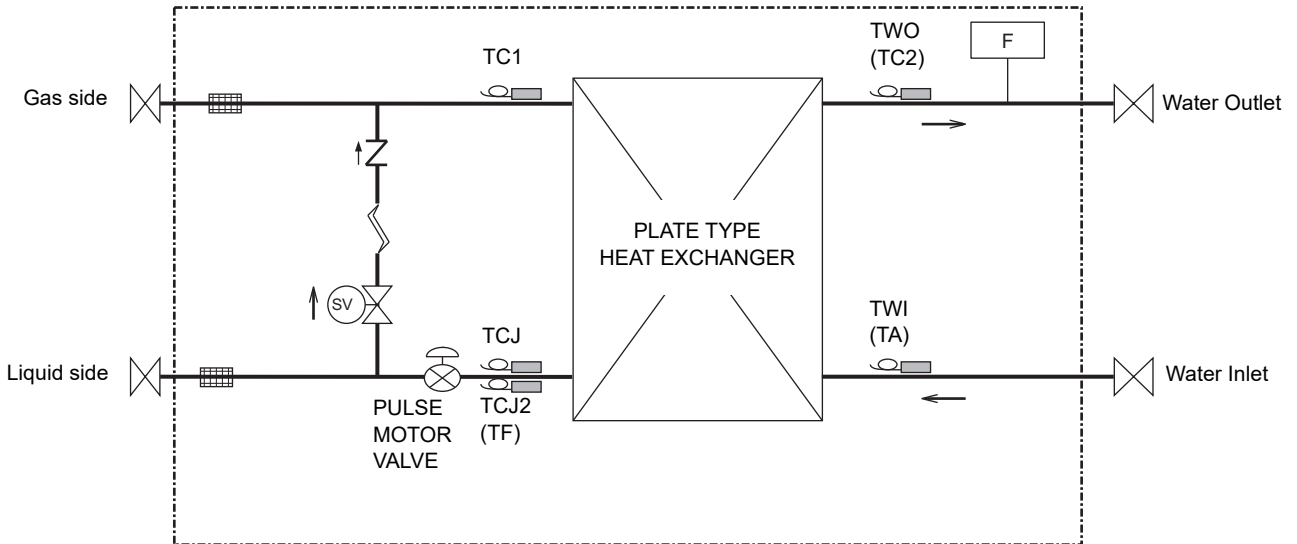

mark						
	SOLENOID VALVE	CAPILLARY TUBE	CHECK VALVE	STRAINER	SENSOR TEMPERATUR	Flow switch

Functional part name		Functional outline
Pulse Motor Valve	PMV	(Connector CN082 (6P): Blue) 1) Controls sub cool in heating operation 2) Recovers refrigerant oil in cooling operation 3) Recovers refrigerant oil in heating operation
Sensor Temperature	1. TWI (TA)	(Connector CN104 (2P): Yellow) 1) Detects Water inlet temperature
	2. TC1	(Connector CN100 (3P): Brown) 1) Detects refrigerant gas temperature
	3. TWO (TC2)	(Connector CN101 (2P): Black) 1) Controls PMV sub cool in heating operation 2) Detects Water outlet temperature
	4. TCJ	(Connector CN102 (2P): Red) 1) Detects refrigerant liquid temperature
	5. TCJ2 (TF)	(Connector CN103 (2P): Green) 1) Detects refrigerant liquid temperature
Solenoid valve	SV	(Connector CN033 (3P): Green) Opens valve to bypass refrigerant to heat exchanger in 1) cooling operation 2) defrost operation
Flow switch	F	(Connector CN030 (3P): Red) 1) Detects water flow

6. Wiring diagram

MMW-UP0271LQ-E, MMW-UP0271LQ-TR, MMW-UP0561LQ-E, MMW-UP0561LQ-TR

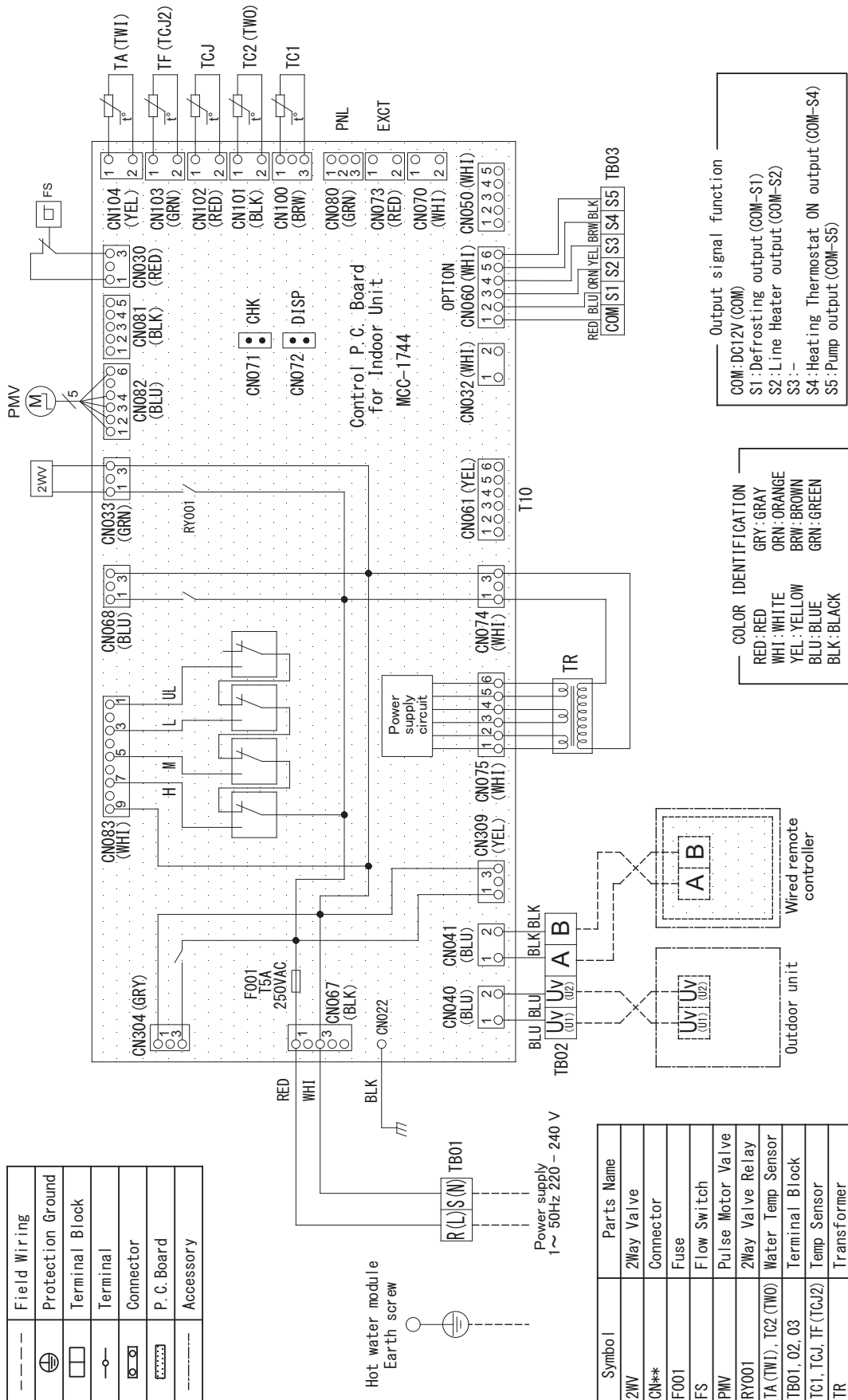

7. Optional connector specifications

Function	Connector No.	Pin No.	Specification	Remarks
HA	CN061	1	Start/ stop input	Start / stop input for HA (J01: In place / Removed = Pulse input (factory default) / Step input)
		2	0 V (COM)	—
		3	Remote controller disabling input	Enables / disables start / stop control via remote controller
		4	In-operation output	ON during operation (HA answerback signal)
		5	DC12 V (COM)	—
		6	Alarm output	ON while alarm ON
Option output (*1)	CN060	1	DC12 V (COM)	—
		2	Defrosting output	ON while outdoor unit ON
		3	Heater output	—
		4	—	—
		5	Heating thermostat output	ON while heating thermostat ON (compressor ON)
		6	Pump output	—
External error input	CN080	1	DC12 V (COM)	Generates test code L30 and automatically shuts down air conditioner (only if condition persists for 1 minute)
		2	DC12 V (COM)	
		3	External error input	
CHK Operation check	CN071	1	Check mode input	Used for hot water module operation check (prescribed operational status output, such as indoor PMV ON, to be generated without communication with outdoor unit or remote controller)
		2	0 V	
DISP Display mode	CN072	1	Display mode input	Product display mode - Communication just between hot water module and remote controller enabled (upon turning on of power) Timer short-circuited out (always)
		2	Display mode input	

*1: For hot water module, terminal block of option output (CN060) is equipped.
Refer to **6. Wiring diagram**.

8. Electrical characteristics

Model	Nominal Voltage	Voltage Range		Power Supply	
	(V-Ph-Hz)	Min.	Max.	MCA	MOCP
MMW-UP0271LQ-E	230-1-50	198	264	0.09	15
MMW-UP0271LQ-TR	230-1-50	198	264	0.09	15
MMW-UP0561LQ-E	230-1-50	198	264	0.09	15
MMW-UP0561LQ-TR	230-1-50	198	264	0.09	15

MCA : Minimum Circuit Amps

MOCP: Maximum Over current Protection (Amps)

9. External wiring diagram

Output signal function wiring

Connect the following output signals from the Hot Water Module.

Terminal block No.	Function	Comments
COM	DC12 V (COM)	Common for connector S2 ~ S5
S1	Defrosting output (COM-S1)	DC12 V Relay coil is less than 16 mA.
S2	Line heater output (COM-S2)	DC12 V Relay coil is less than 16 mA.
S3	-	-
S4	Heating thermostat ON output (COM-S4)	DC12 V Relay coil is less than 16 mA.
S5	Pump output (COM-S5)	DC12 V Relay coil is less than 16 mA.

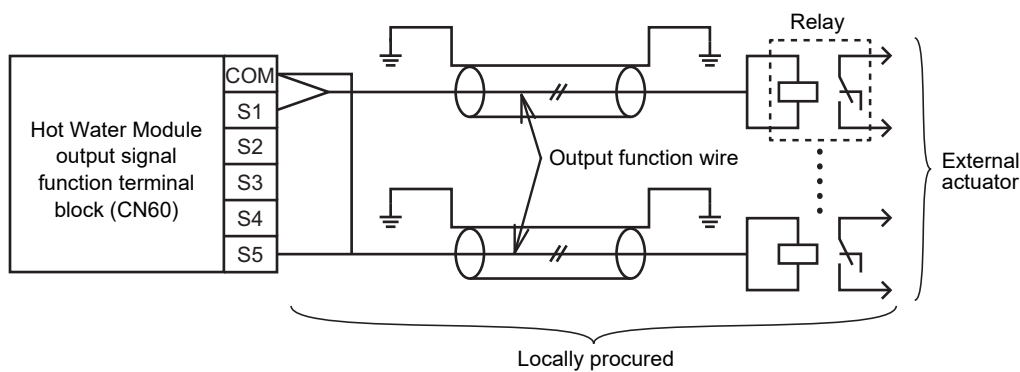

NOTE

Auxiliary relays (locally procured) must be connected to output signal function wirings to allow connection to the Hot Water Module output signal functions. The maximum current output signal, from each of the output signal function wirings, is 16 mA. Please ensure the rated current of the relay coil is less than 16 mA to avoid damage to the Hot Water Module P.C. board.

CAUTION

Output signal functions are separated from primary basic insulation.

- To prevent noise trouble, use 2-core shield wire.
- Determine the wire length between the Hot Water Module output signal function terminal block and the relay up to 2 m.
- Locally procure and install protective devices such as the heater and pump.

Optional connector function table

Function	Connector No.	Pin No.	Specification	Remarks
Optional output	CN60	1	DC12 V (COM)	
		2	Defrosting output	ON while outdoor unit ON
		3	Heater output	
		4	-	
		5	Heating thermostat output	ON while heating thermostat ON (compressor ON)
		6	Pump output	

Wiring between indoor (including Hot Water Module) and outdoor units

NOTE

- An outdoor unit connected with control wiring between indoor (including Hot Water Module) and outdoor units wire becomes automatically the header unit.
- Do not turn off the circuit breaker of the Hot Water Module when the circuit breaker of the system (outdoor unit) is set to the ON position.
- It becomes a cause of a trouble.

▼ Wiring example of SMMS-e

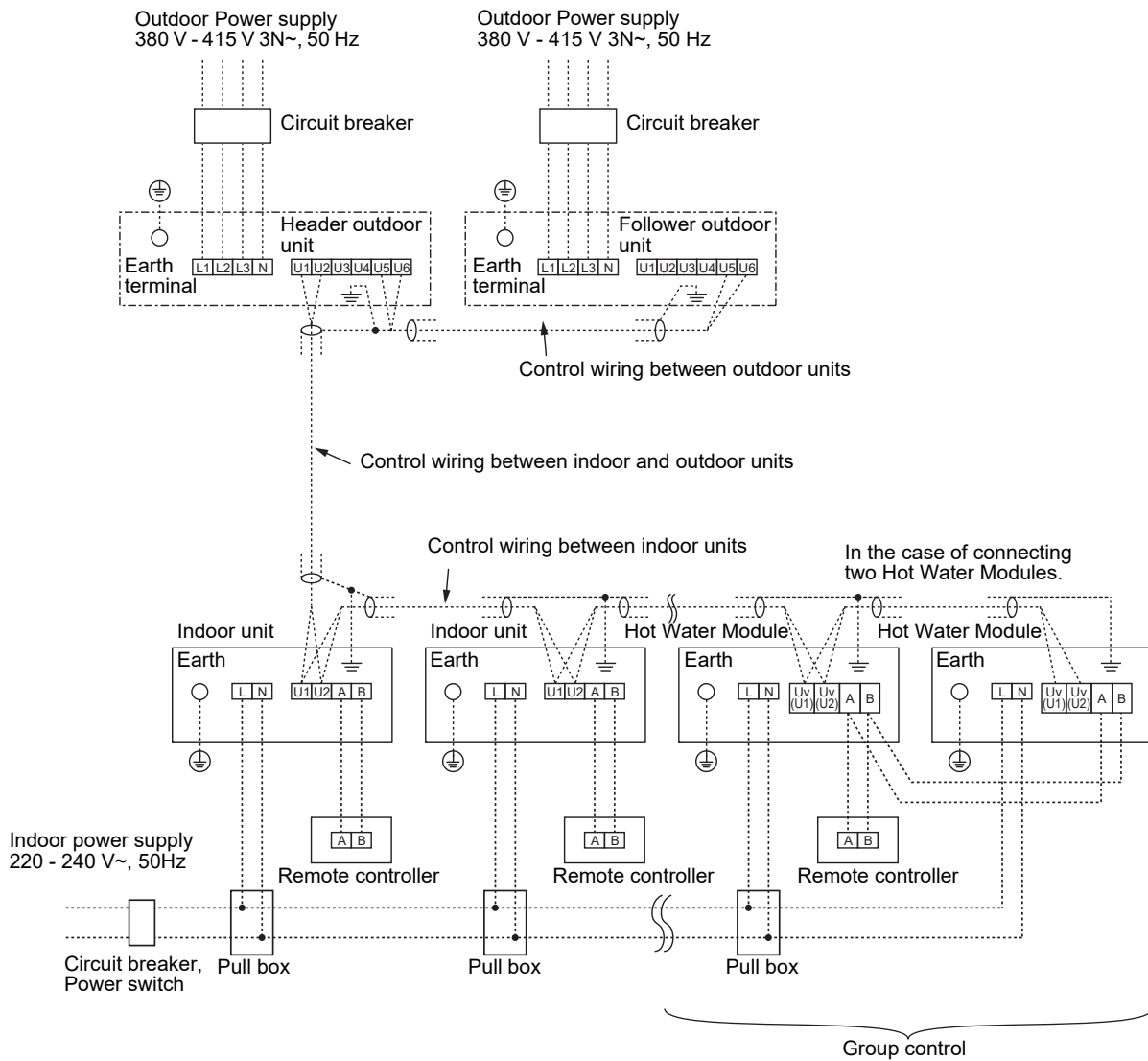

▼ Power supply

- Power supply wire specification: Cable 3-core 2.5 mm², in conformity with Design 60245 IEC 57.

Power supply	220 - 240 V~, 50 Hz	
Power supply switch / circuit breaker or power supply wiring / fuse rating for Hot Water Module should be selected by the accumulated total current values of the Hot Water Module.		
Power supply wiring	Below 50 m	2.5 mm ²

Control wiring, Central controller wiring

- 2-core with non-polarity wires are used for the Control wiring between indoor unit (including Hot Water Module) and outdoor unit and Central controller wiring.
- To prevent noise trouble, use 2-core shield wire.
- The length of the communication line means the total length of the inter-unit wire length between indoor (including Hot Water Module) and outdoor units added with the central control system wire length.

▼ Communication line

Control wiring between indoor units (including Hot Water Module), and outdoor unit (2-core shield wire)	Wire size	(Up to 1000 m) 1.25 mm ² (Up to 2000 m) 2.0 mm ²
Central control line wiring (2-core shield wire)		

Remote controller wiring

- 2-core with non-polarity wire is used for wiring of the remote controller wiring and group remote controllers wiring.

Remote controller wiring, remote controller inter-unit wiring	Wire size: 0.5 mm ² to 2.0 mm ²	
Total wire length of remote controller wiring and remote controller inter-unit wiring = L + L1 + L2 + ... Ln	In case of wired type only	Up to 500 m
	In case of wireless type included	Up to 400 m
Total wire length of remote controller inter-unit wiring = L1 + L2 + ... Ln	Up to 200 m	

Output signal function wiring

- To prevent noise trouble, use 2-core shield wire.

Output function wiring (2-core shield wire)	Wire size	(up to 2 m) 0.5 mm ²
---	-----------	---------------------------------

▼ Wiring example of SHRM-e

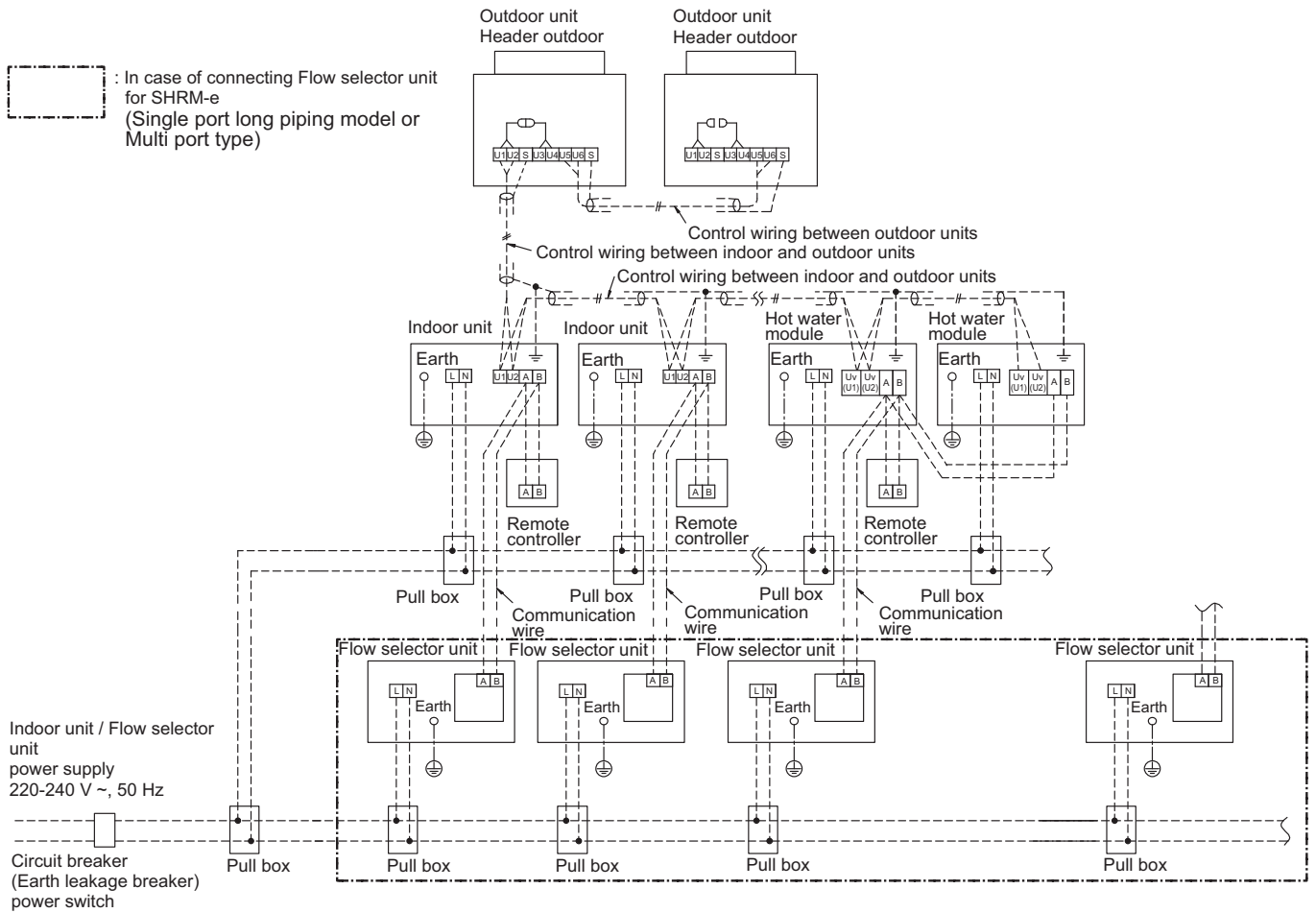

▼ Power supply

Power supply	220 V – 240 V ~, 50 Hz	
Power supply switch / circuit breaker or power supply wiring / fuse rating for hot water module should be selected by the accumulated total current values of the hot water module.		
Power supply wiring	Below 50 m	2.5 mm ²

Control wiring, Central controller wiring

- 2-core with non-polarity wires are used for the Control wiring between indoor unit (including hot water module) and outdoor unit and Central controller wiring.
- To prevent noise trouble, use 2-core shield wire.
- The length of the communication line means the total length of the inter-unit wire length between indoor (including hot water module) and outdoor units added with the central control system wire length.

▼ Communication line

Control wiring between indoor units (including hot water module), and outdoor unit (2-core shield wire)	Wire size	(Up to 1000 m) 1.25 mm ² (Up to 2000 m) 2.0 mm ²
Central control line wiring (2-core shield wire)		

Remote controller wiring

- 2-core with non-polarity wire is used for wiring of the remote controller wiring and group remote controllers wiring.

Remote controller wiring, remote controller inter-unit wiring	Wire size: 0.5 mm ² to 2.0 mm ²
---	---

Connecting to SHRM-e	
Total wire length between indoor unit and Flow selector unit (L2 + L3)	Up to 200 m
Total wire length between remote controller and Flow selector unit (L1 + L2 + L3)	Up to 300 m
Maximum wire length of remote controller (L1)	Up to 300 m

Output signal function wiring

- To prevent noise trouble, use 2-core shield wire.

Output function wiring (2-core shield wire)	Wire size	(up to 2 m) 0.5 mm ²
---	-----------	---------------------------------

▼ Wiring example of SMMS-u

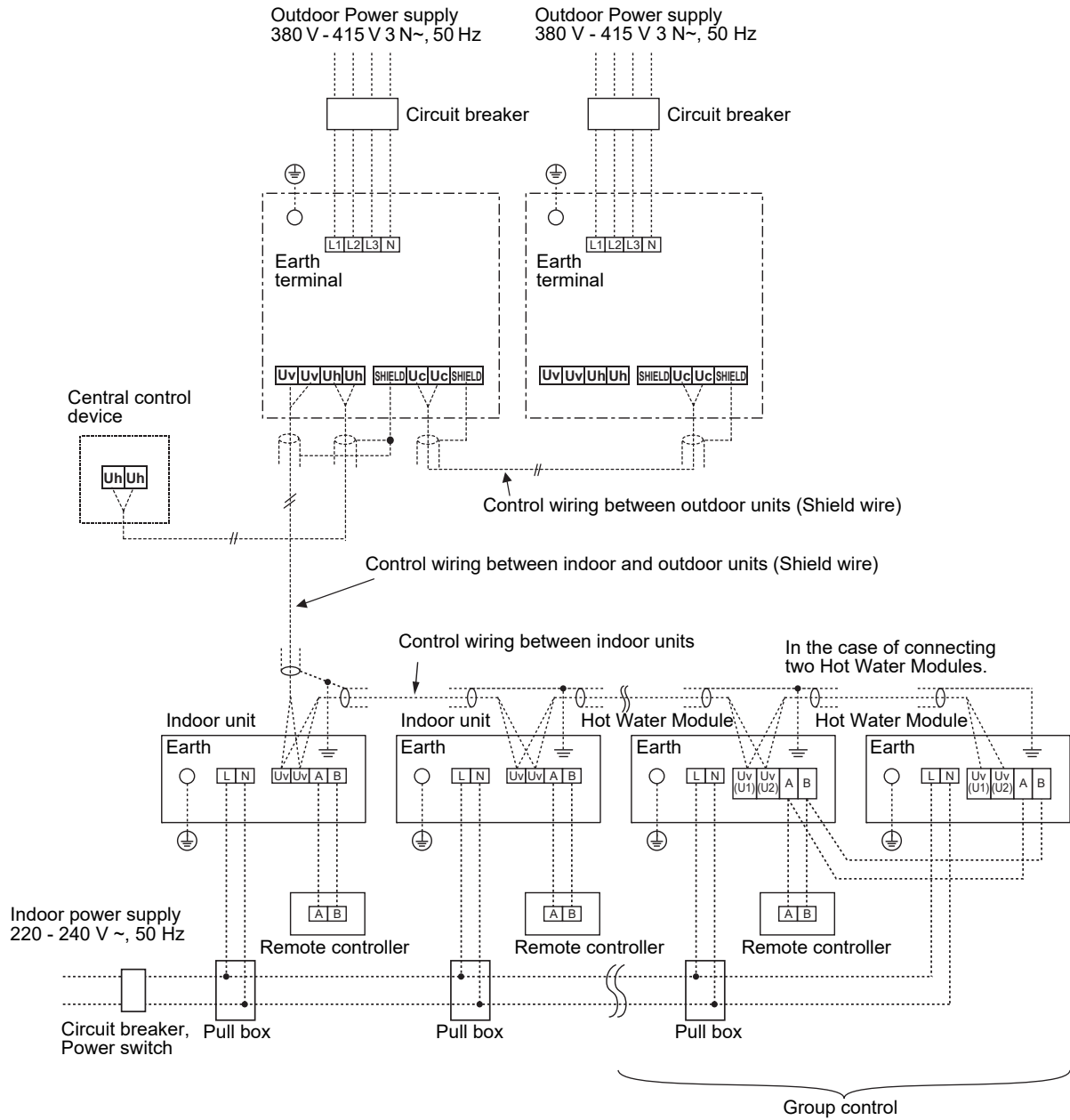

▼ Power supply

Power supply	220 - 240 V~, 50 Hz	
Power supply switch / circuit breaker or power supply wiring / fuse rating for hot water module should be selected by the accumulated total current values of the hot water module.		
Power supply wiring	Below 50 m	2.5 mm ²

Control wiring, Central controller wiring

- 2-core with non-polarity wires are used for the Control wiring between indoor unit (including hot water module) and outdoor unit and Central controller wiring.
- To prevent noise trouble, use 2-core shield wire.
- The length of the communication line means the total length of the inter-unit wire length between indoor (including hot water module) and outdoor units added with the central control system wire length.

▼ Communication line

Control wiring between indoor units (including hot water module), and outdoor unit (2-core shield wire)	Wire size	(Up to 1000 m) 1.25 mm ² (Up to 2000 m) 2.0 mm ²
Central control line wiring (2-core shield wire)		

Remote controller wiring

- 2-core with non-polarity wire is used for wiring of the remote controller wiring and group remote controllers wiring.

Remote controller wiring, remote controller inter-unit wiring	Wire size: 0.5 mm ² to 2.0 mm ²	
Total wire length of remote controller wiring and remote controller inter-unit wiring = L + L1 + L2 +...Ln	In case of wired type only	Up to 500 m
	In case of wireless type included	Up to 400 m
Total wire length of remote controller inter-unit wiring = L1 + L2 +...Ln		Up to 200 m

Output signal function wiring

- To prevent noise trouble, use 2-core shield wire.

Output function wiring (2-core shield wire)	Wire size	(up to 2 m) 0.5 mm ²
---	-----------	---------------------------------

▼ Wiring example of SHRM-A

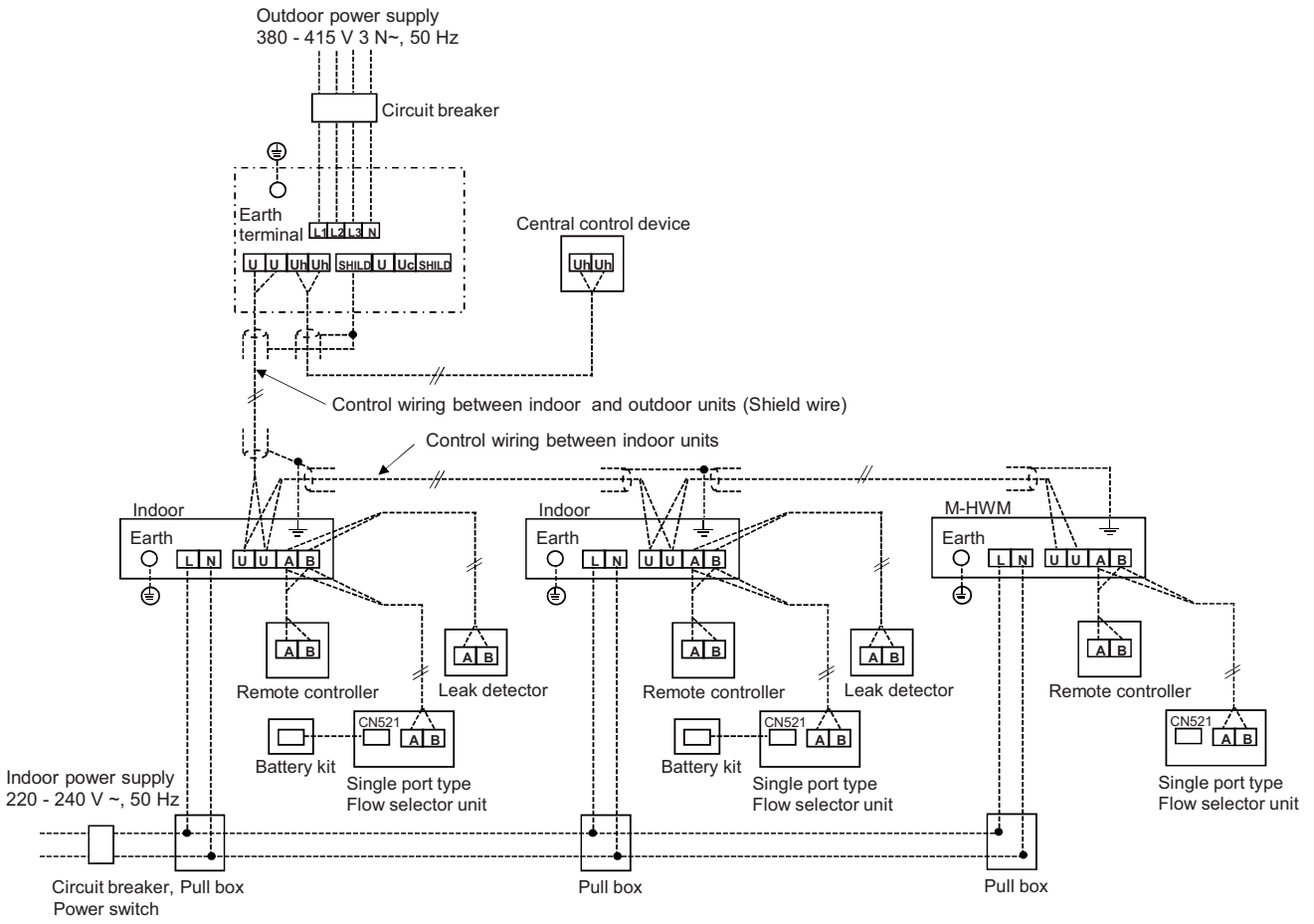

▼ Power supply

Power supply	220 - 240 V~, 50 Hz	
Power supply switch / circuit breaker or power supply wiring / fuse rating for Hot Water Module should be selected by the accumulated total current values of the Hot Water Module.		
Power supply wiring	Below 50 m	2.5 mm ²

Control wiring, Central controller wiring

- 2-core with non-polarity wires are used for the Control wiring between indoor unit (including Hot Water Module) and outdoor unit and Central controller wiring.
- To prevent noise trouble, use 2-core shield wire.
- The length of the communication line means the total length of the inter-unit wire length between indoor (including Hot Water Module) and outdoor units added with the central control system wire length.

▼ Communication line

Control wiring between indoor units (including Hot Water Module), and outdoor unit (2-core shield wire)	Wire size	(Up to 1000 m) 1.25 mm ² (Up to 2000 m) 2.0 mm ²
Central control line wiring (2-core shield wire)		

Remote controller wiring

- 2-core with non-polarity wire is used for wiring of the remote controller wiring and group remote controllers wiring.

Remote controller wiring, remote controller inter-unit wiring	Wire size: 0.5 mm ² to 2.0 mm ²	
Total wire length of remote controller wiring and remote controller inter-unit wiring = L + L1 + L2 + ... Ln	In case of wired type only	Up to 500 m
	In case of wireless type included	Up to 400 m
Total wire length of remote controller inter-unit wiring = L1 + L2 + ... Ln	Up to 200 m	

Output signal function wiring

- To prevent noise trouble, use 2-core shield wire.

Output function wiring (2-core shield wire)	Wire size	(up to 2 m) 0.5 mm ²
---	-----------	---------------------------------

▼ Wiring example of MiNi SMMS-e

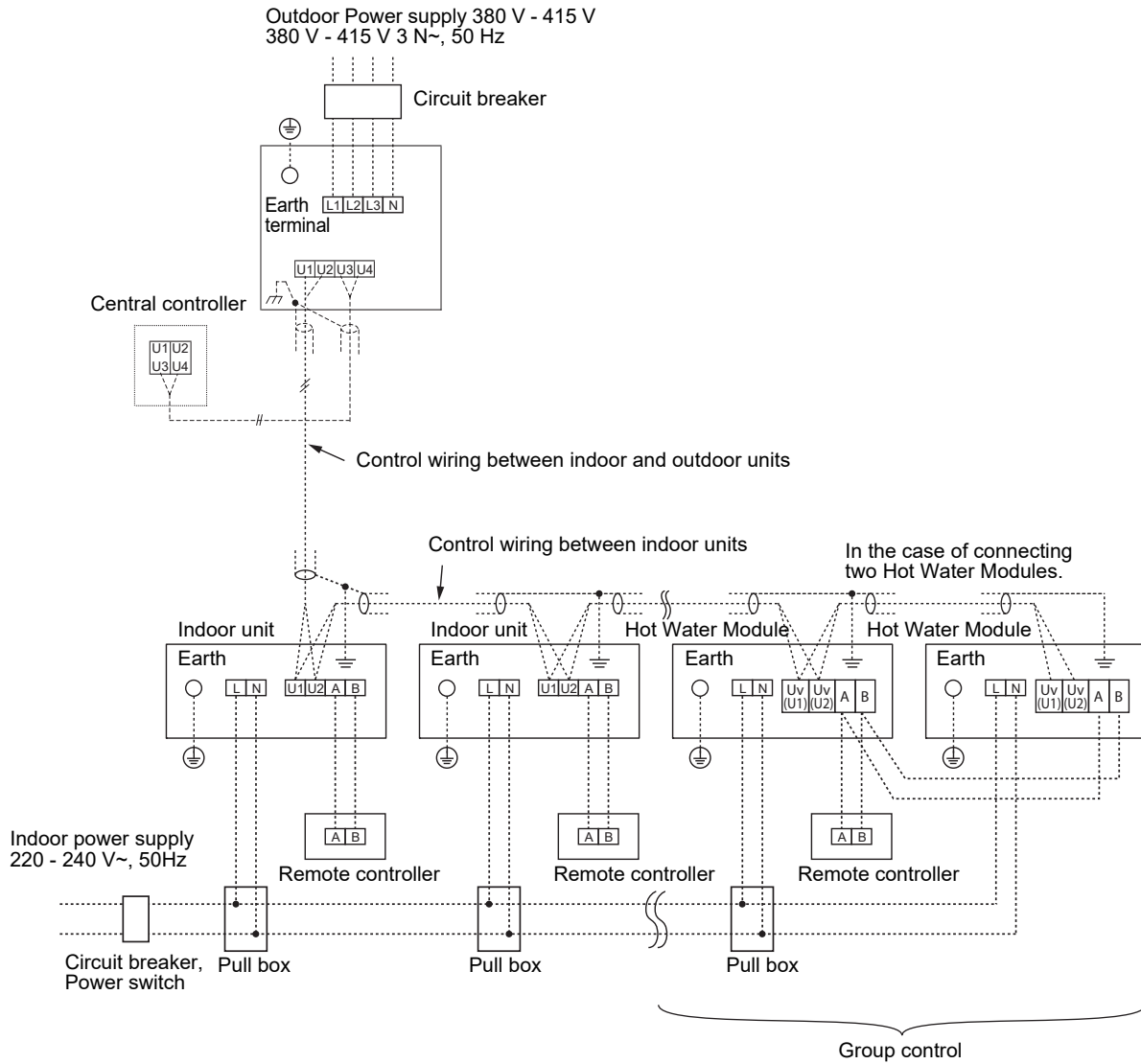

▼ Power supply

- Power supply wire specification: Cable 3-core 2.5 mm², in conformity with Design 60245 IEC 57.

Power supply	220 - 240 V~, 50Hz	
Power supply switch / circuit breaker or power supply wiring / fuse rating for Hot Water Module should be selected by the accumulated total current values of the Hot Water Module.		
Power supply wiring	Below 50 m	2.5 mm ²

Control wiring, Central controller wiring

- 2-core with non-polarity wires are used for the Control wiring between indoor unit (including Hot Water Module) and outdoor unit and Central controller wiring.
- To prevent noise trouble, use 2-core shield wire.
- The length of the communication line means the total length of the inter-unit wire length between indoor (including Hot Water Module) and outdoor units added with the central control system wire length.

▼ Communication line

Control wiring between indoor units (including Hot Water Module), and outdoor unit (2-core shield wire)	Wire size	(Up to 1000 m) 1.25 mm ² (Up to 2000 m) 2.0 mm ²
Central control line wiring (2-core shield wire)		

Remote controller wiring

- 2-core with non-polarity wire is used for wiring of the remote controller wiring and group remote controllers wiring.

Remote controller wiring, remote controller inter-unit wiring	Wire size: 0.5 mm ² to 2.0 mm ²	
Total wire length of remote controller wiring and remote controller inter-unit wiring = L + L1 + L2 + ... Ln	In case of wired type only	Up to 500 m
	In case of wireless type included	Up to 400 m
Total wire length of remote controller inter-unit wiring = L1 + L2 + ... Ln	Up to 200 m	

Output signal function wiring

- To prevent noise trouble, use 2-core shield wire.

Output function wiring (2-core shield wire)	Wire size	(up to 2 m) 0.5 mm ²
---	-----------	---------------------------------

Group operation through a remote controller

Group operation of multiple indoor units (8 units)*1 through a single remote controller switch

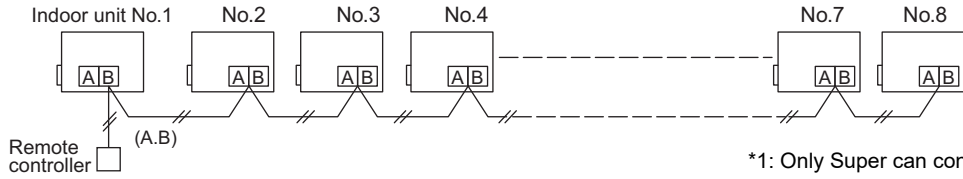

How to connect a group of remote operation controller

HWM: Mid temperature Hot Water Module

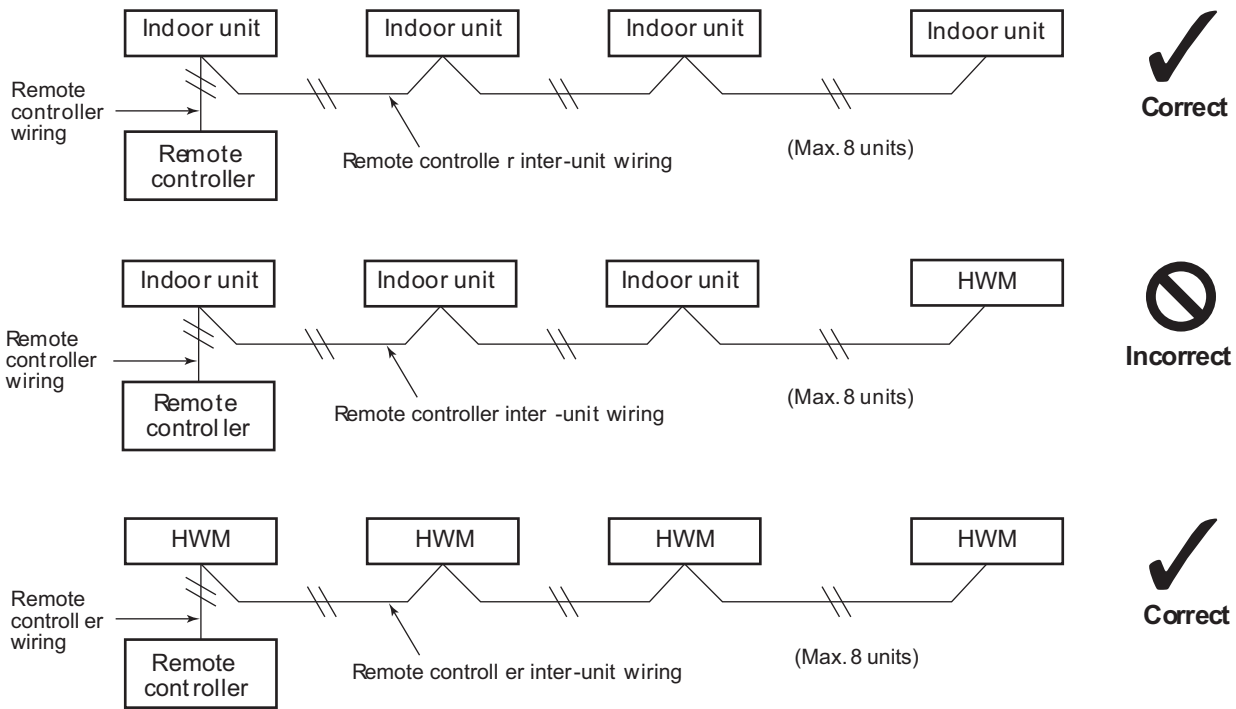

NOTE

It is not possible to connect any Hot Water Modules and any indoor units together for group control.

Remote controller sensor

CAUTION

Remote controller sensor cannot be used for the Hot Water Module.
 Remote controller sensor has no function when remote controller is connected to the Hot Water Module.

10. Water side characteristics

Hot Water Module operation temperature range

■ SMMS-e Heating & SMMS-u Heating & SHRM-A Heating

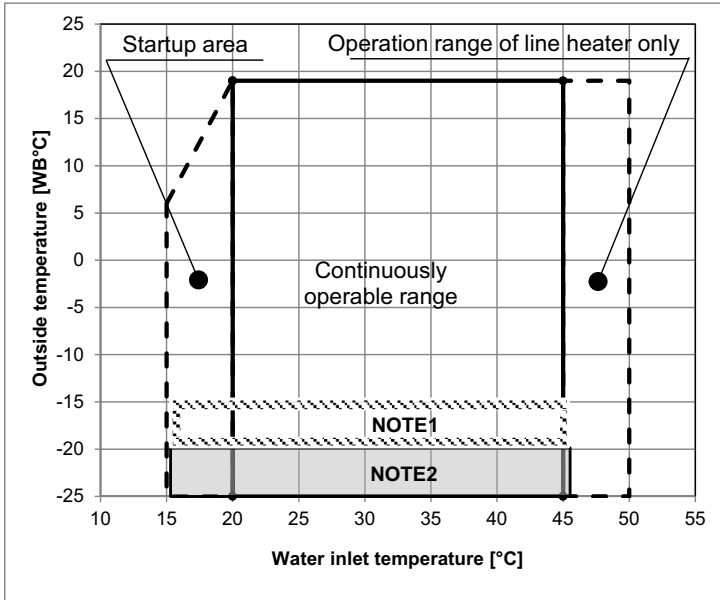

NOTE1 The unit will operate down to an outdoor temperature of -25°C, however considerable performance decrease will be expected below -15°C. Therefore, please consider installation location/surroundings and system design when expected to operate between -15°C and -20°C.

NOTE2 Low ambient heating (-20°C or less) for extended periods of time is not allowed.

■ SHRM-e Heating

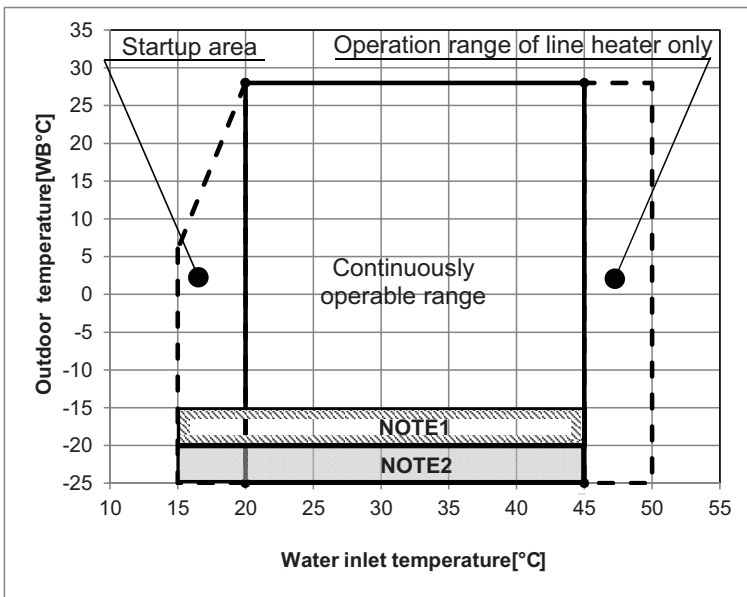

NOTE1 The unit will operate down to an outdoor temperature of -25°C, however considerable performance decrease will be expected below -15°C. Therefore, please consider installation location/surroundings and system design when expected to operate between -15°C and -20°C. Avoid the following place
Places where ambient temperature falls below -15°C for more than 72 hours running/The outdoor heat exchanger may be damaged by the frost.

NOTE2 Low ambient heating (-20°C or less) for extended periods of time is not allowed.

■ MiNi SMMS-e

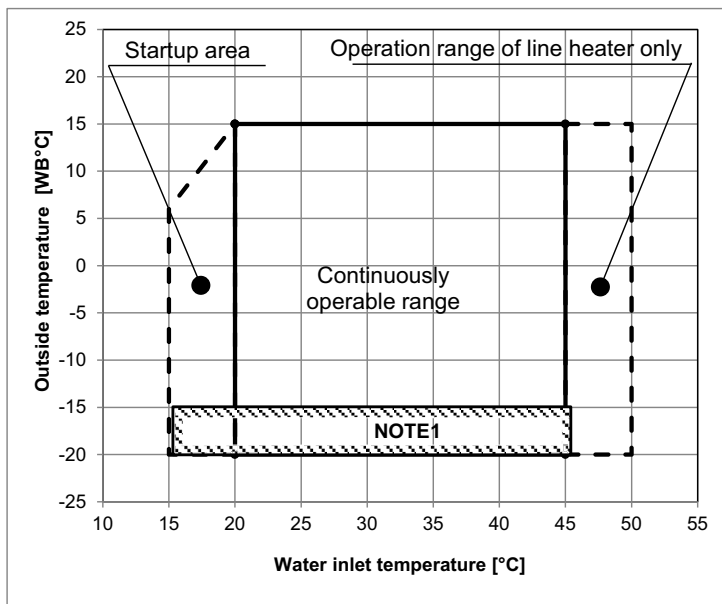

NOTE 1 The unit will operate down to an outdoor temperature of -20°C, however considerable performance decrease will be expected below -15°C. Therefore, please consider installation location/surroundings and system design when expected to operate between -15°C and -20°C.

Hot Water Module capacity characteristics

As with standard air conditioners, the heating capacity of the Hot Water Module decreases according to the decrease in outdoor temperature and total indoor unit capacity (kW). (The characteristics graphs below are made using an auxiliary heater with 40% of the Hot water Module's rated capacity and rated flow rate. *)

*rated flow rate 027 Type: 22.9 L/min, 056 Type: 45.8 L/min

The line heater turns off when the inlet water temperature is close to the setting water temperature.

The Hot Water Module does not have sufficient heating capacity to be used in low outdoor temperatures with no auxiliary heater. Therefore, provide a heater or similar on the side of the device being used to compensate for the lack of heating capacity indicated in the characteristics graph below.

MMW-UP0271LQ-E/TR, MMW-UP0561LQ-E/TR

Combination outdoor unit: SMMS-e, SHRM-e, SMMS-u, MiNi SMMS-e

SMMS-e can be operated up to 19°CWB.

SHRM-e can be operated up to 28°CWB.

SMMS-u can be operated up to 19°CWB.

SHRM Advance can be operated to 28°CWB.

MiNi SMMS-e can be operated up to 19°CWB.

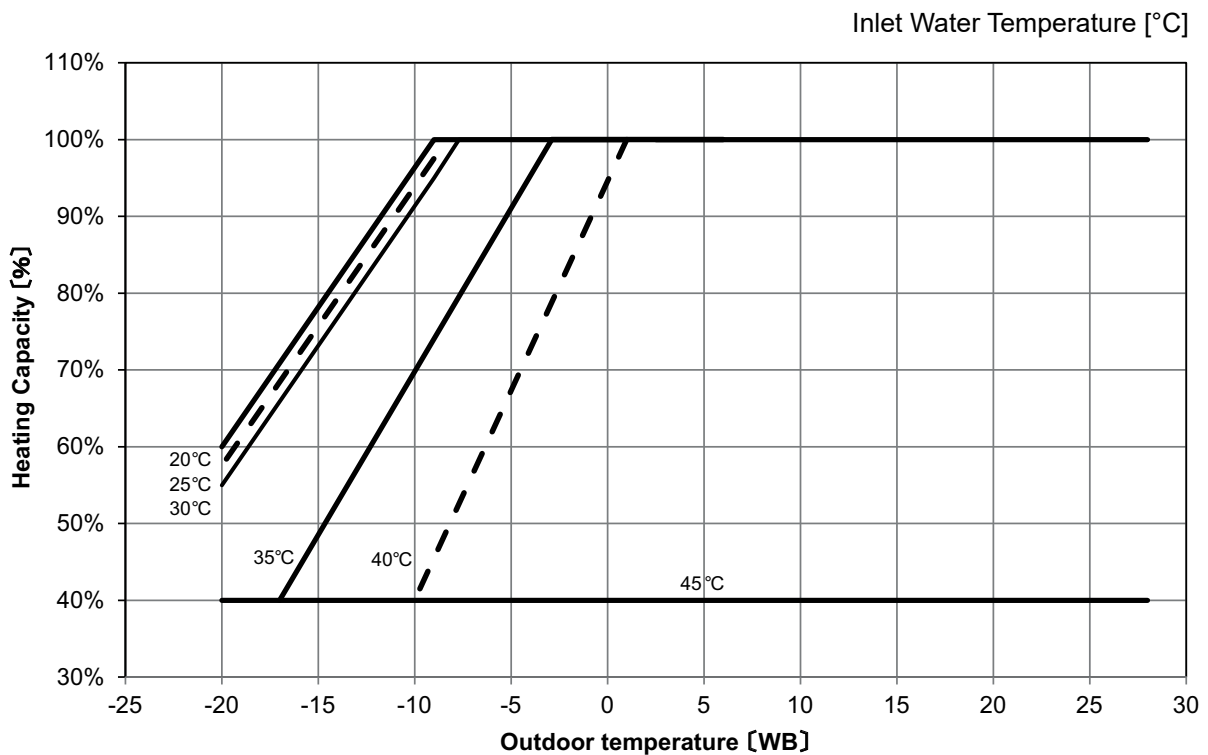

Booster Heater capacity simple selection table

Water piping installation example

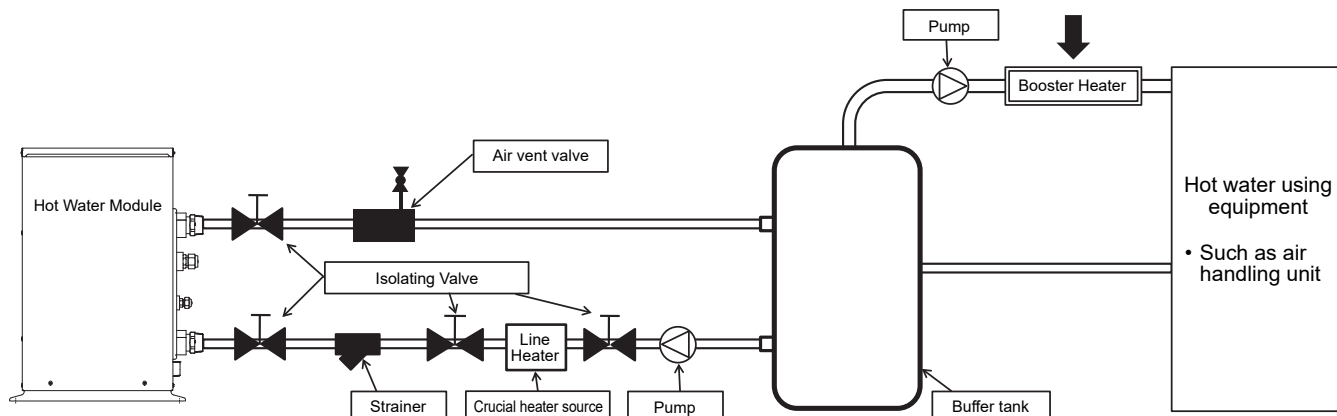

Booster Heater capacity (%: Hot Water Module rated capacity ratio) simple selection table

Outdoor temperature WB °C	Remote controller set temperature Ts			
	25 ≤ Ts ≤ 35	36 ≤ Ts ≤ 40	41 ≤ Ts ≤ 45	46 ≤ Ts ≤ 50
-20 ≤ TO < -15	45	60	60	60
-15 ≤ TO < -10	30	55	60	60
-10 ≤ TO < -5	10	30	60	60
-5 ≤ TO < 0	0	10	35	60
0 ≤ TO < 5	0	0	5	60
0 ≤ TO < 19	0	0	0	60

TO: Outdoor temperature

The table shows the values in the case of connecting the auxiliary heater of 40% Hot Water Module rated capacity ratio.

Characteristics of Hot Water Module flow rate and pressure loss

The following graph shows the range of flow rates used for the Hot Water Module, and the characteristic pressure losses. Use this as an aid in the local pump procurement process.

027 type

	Minimum	Rated	Maximum
Water flow rate (L/min)	19.5	22.9	26.3
Pressure loss (kPa)	28.5	40.5	53.5

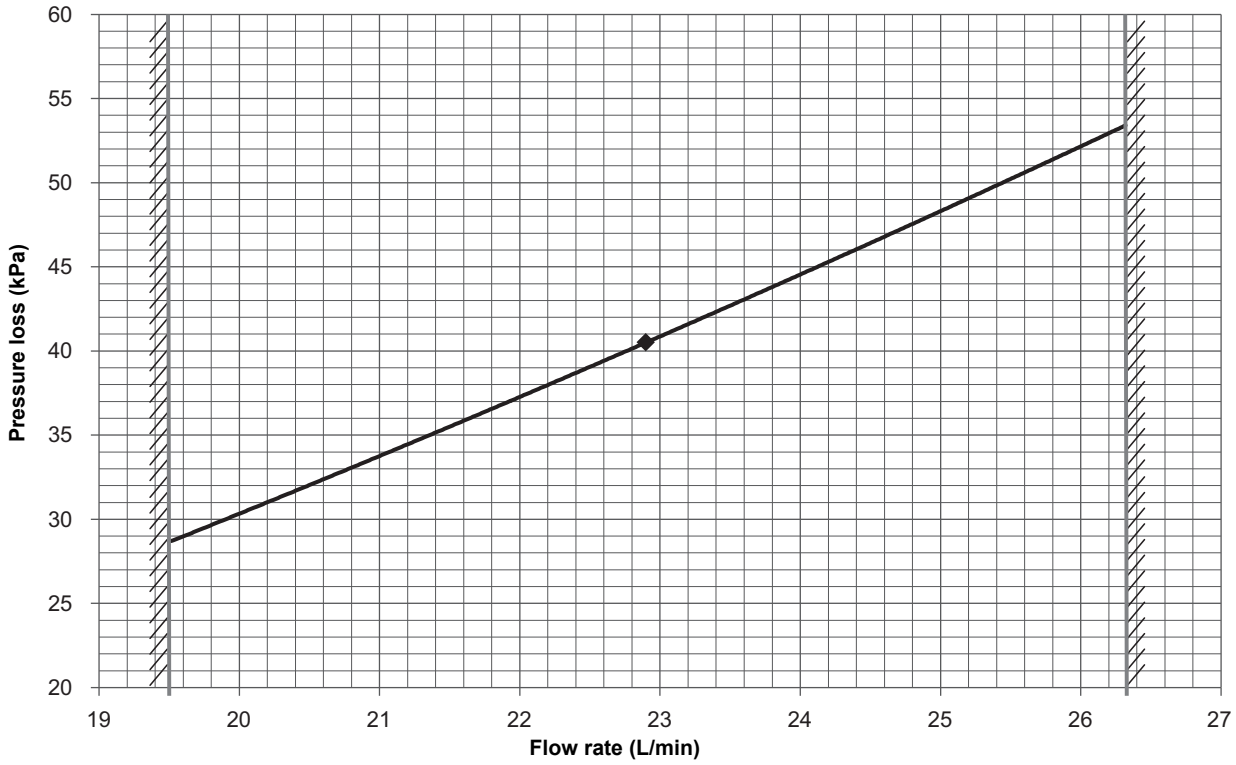

056 type

	Minimum	Rated	Maximum
Water flow rate (L/min)	38.9	45.8	52.6
Pressure loss (kPa)	35.2	44.2	58.2

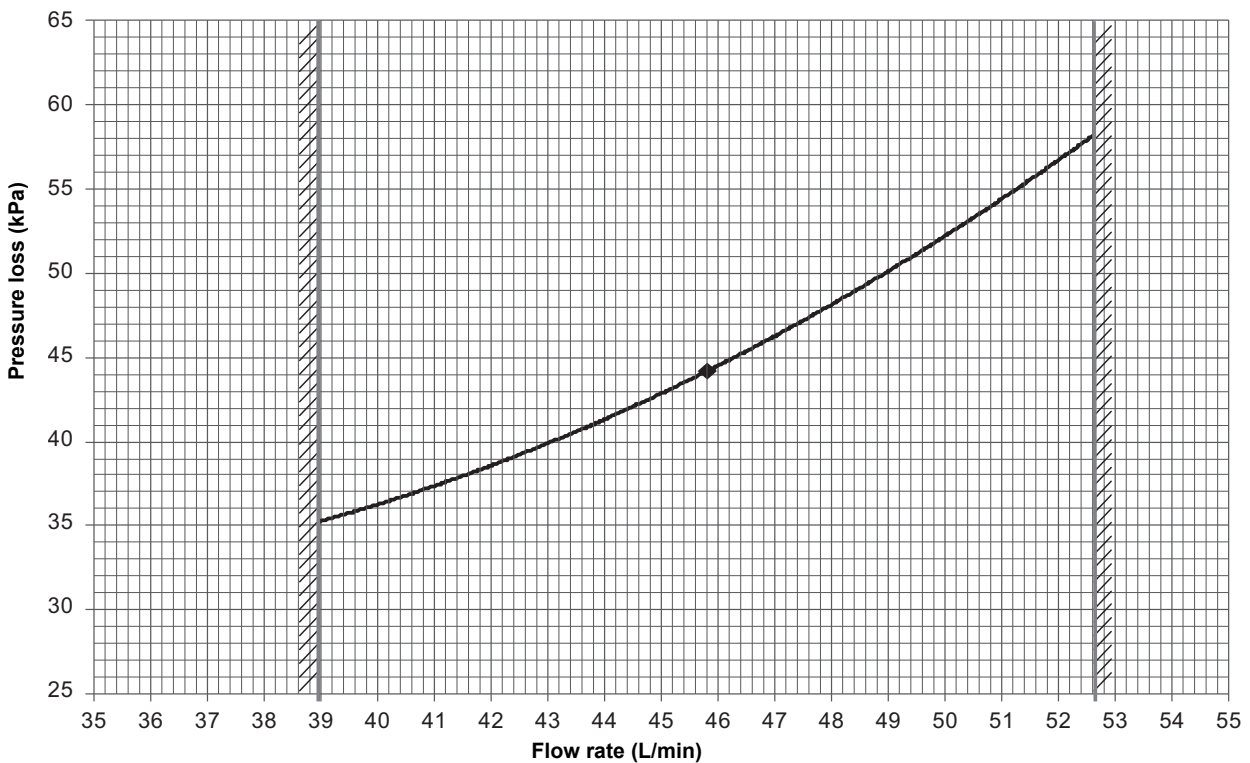

11. Sound data

Sound characteristics of Hot Water Module
MMW-UP0271LQ-E/TR

Sound pressure level dB(A)	Heating
	25

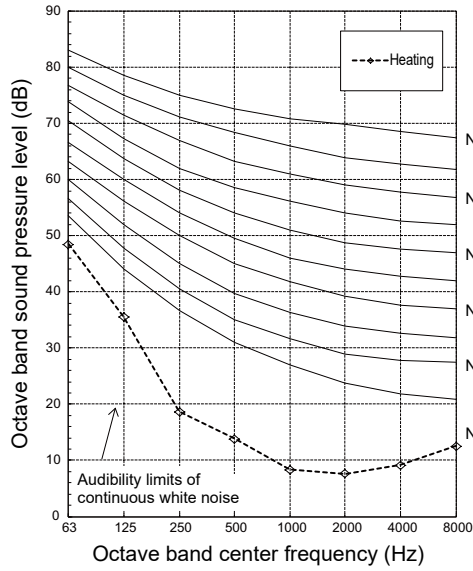

MMW-UP0561LQ-E/TR

Sound pressure level dB(A)	Heating
	27

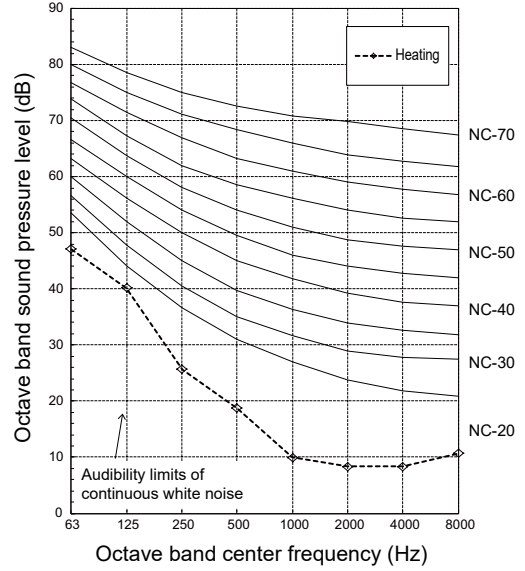

Measuring location

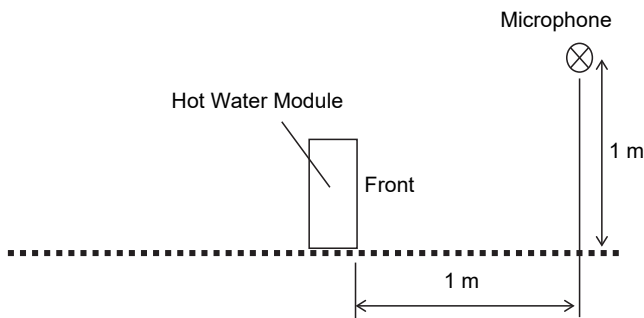

12. Caution of installation

Water piping

WARNING

- Install water pipes according to the regulations of respective countries.
- Install water pipes in the freeze-free place.
- Make sure that water pipes have sufficient pressure resistance. The design pressure is 1.0 MPa.

CAUTION

- Do not use zinc plated water pipes. When steel pipes are used, insulate both ends of the pipes.
- Copper pipes are recommended.
- The water to be used must meet the water quality standard specified in EN directive 98/83 EC.
After the vacuuming is completed, carry out the following procedure before adding refrigerant.
- Plate heat exchanger may explode because the water in the plate heat exchanger frozen.
To avoid this phenomenon, add refrigerant before carrying out a water supply to the water pipe system of the Hot Water Module.
- The hot water module and the buffer/cylinder tank must be installed on the same floor height.
- The water piping on the inlet side of the hot water module must not be connected with right-angled loop piping (refer to the figure below).
- When flow switch detects a decrease in the water flow rate, the outdoor unit stops.

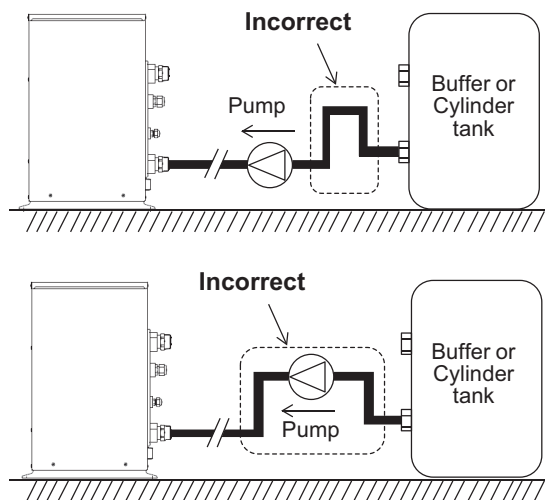

Water piping and line heater installation

- Make the piping route a closed circuit. (An open water circuit may cause a failure.)
- Before a long period of none use, purge the water out of the pipes and thoroughly let them dry.
- Do not add brine to the circulating water.
- Do not use the water used for the unit for drinking or food manufacturing.
- To ensure easy maintenance, inspection, and replacement of the unit, use a proper joint, valve, etc. (procured locally) on the water inlet and outlet port.
- Be sure to install a strainer with 30 to 40 meshes (procured locally) on the water inlet pipe. If a strainer is not installed, this may cause impaired performance, or damage to the plate heat exchanger from freezing.
- Install a suitable air vent (procured locally) on the water pipe. After sending water through the pipe, be sure to vent the excess air.
- To avoid water leak, wrap some sealing tape around the screw part.
- Water pipes can get very hot, depending on the preset temperature. Wrap the water pipes with heat insulation (procured locally) to prevent burns.
- Be sure to install the line heater (procured locally) on the water inlet side. In addition, position it within 5 m of the water inlet pipe of the Hot Water Module.
- Follow the table below to select a line heater (procured locally) within the range of 40 to 50% of the Hot Water Module's rated capacity.

Hot Water Module model name	Capacity of line heater (kW)
MMW-UP0271LQ-E/TR	3.2 - 4.0
MMW-UP0561LQ-E/TR	6.4 - 8.0

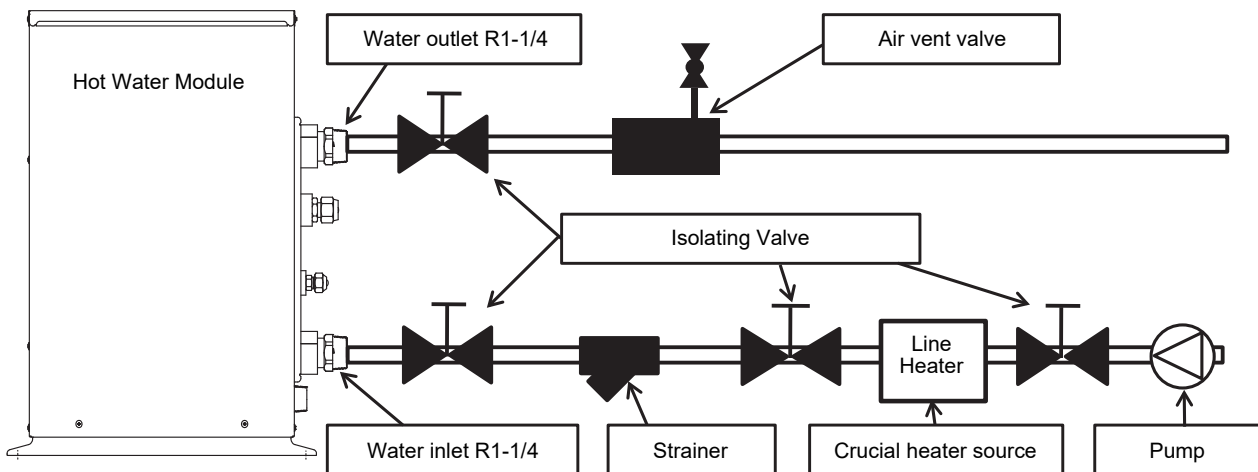

Pipe size, material and insulator

The following specification for piping work and insulating process are procured locally.

Model		MMW-	UP027	UP056
Connecting pipe (unit side)	Water pipe	Inlet	R1 - 1/4	
		Outlet	R1 - 1/4	
Connecting pipes material			Copper pipes are recommended	
Insulator			Formed polyethylene foam, thickness: 10 mm or more	

Drain piping

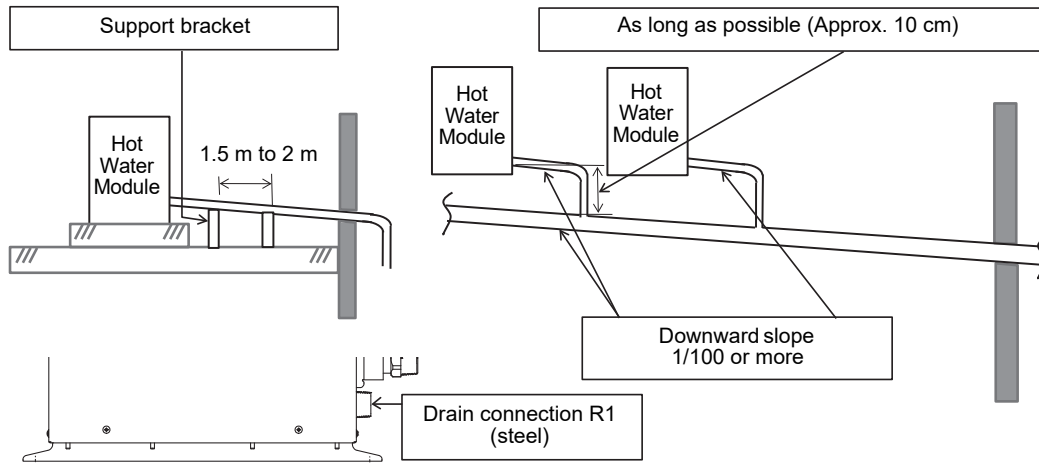

Pipe material, size and insulator

The following materials for piping work and insulating process are procured locally.

Pipe material	Hard vinyl chloride pipe, VP25A (Nominal outer diameter 32 mm)
Insulator	Foamed polyethylene foam, thickness: 10 mm or more

Heat insulating process

- After drain check, covering the heat insulator for drain connecting section, wrap the drain pipe with heat insulator (Locally procured) without clearance from the end of the drain pipe connecting port of the Hot Water Module.

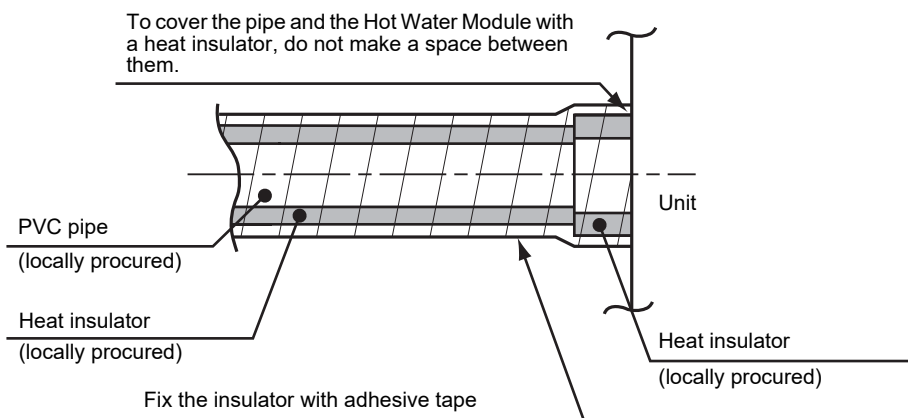

Check the following contents

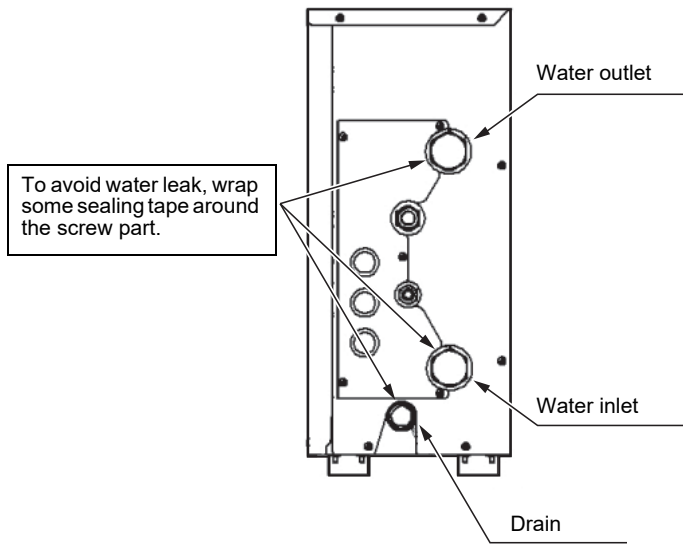

Selection of installation place

Avoid installing in the following places

- Saline area (coastal area)
- Locations with acidic or alkaline atmospheres (such as areas with hot springs, factories where chemicals or pharmaceuticals are made, and places where the exhaust air from combustion appliances will be sucked into the unit).
Doing so may cause the heat exchanger and other parts to become corroded.
- Locations with atmospheres with mist of cutting oil or other types of machine oil.
Doing so may cause the heat exchanger to become corroded, the plastic parts to be damaged, the heat insulators to peel off, and other such problems to result.
- Locations where vapors from food oils are formed (such as kitchens where food oils are used).
The plastic parts to be damaged, and other such problems to result.
- Locations where an in-house power generator is used for the power supply.
The power line frequency and voltage may fluctuate, and the Hot Water Module may not work properly as a result.
- On truck cranes, ships or other moving conveyances.
- Locations where high frequencies are generated by inverter equipment, in-house power generators, medical equipment or communication equipment.
The high frequencies may cause a malfunction or control trouble in the Hot Water Module.
- Locations where there is anything under the unit installed that would be compromised by wetness.
(If the drain has become blocked or when the humidity is over 85%, condensation from the Hot Water Module will drip, possibly causing damage to anything underneath.)
- Locations where organic solvents are being used.
- Locations where liquefied carbon dioxide gas is handled (e.g. in chemical plants).
- Locations near doors or windows where the Hot Water Module may come into contact with high-temperature, high humidity outdoor air.
(Condensation may occur as a result.)
- Locations where special sprays are used frequently.
- Locations where iron or other metal dust is present. If iron or other metal dust adheres to or collects on the interior of the Hot Water Module, it may spontaneously combust and start a fire.
- Locations such as living rooms and bedrooms where you can easily be bothered by noise. Noise may become a problem.

CAUTION

- The Hot Water Module must be installed in accordance with national wiring regulation.
- Do not use Hot Water Module for special applications (e.g. storing the plants or precision instruments). The quality of the items stored may be degraded.
- Do not install the Hot Water Module in the following places.
 - Place where water freezes
 - Place where combustible gas may leak
 - Place exposed to rain or water
 - Place near equipment which generates heat
 - Place exposed to vibration
 - Place with a high humidity
 - Place with a lot of dust

Installation atmosphere

Installation atmosphere of the unit is as follows. Be careful of installation atmosphere. It becomes a cause of failure of a product by dewing or freezing.

Installation atmosphere	Dry-bulb temp. (°C)	5 to 32
	Wet-bulb temp. (°C)	24 (Max.)
	RH (%)	30 to 85
	Allowable dew point (°C Wet-bulb temp)	23 or less

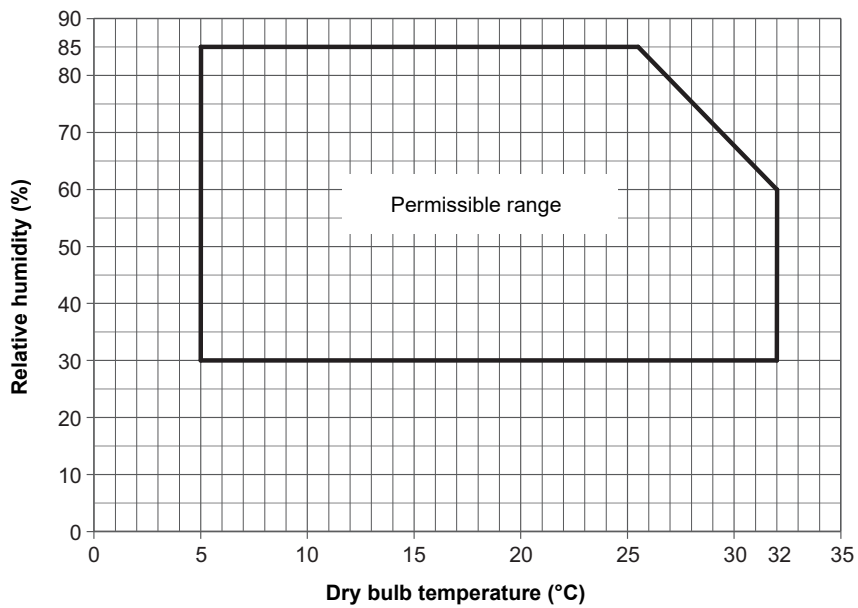

Buffer Tank Installation

A buffer tank must be installed in order to stabilize the temperature of the water supplied when using a Hot Water Module to the heating equipment such as a radiator or floor heating.

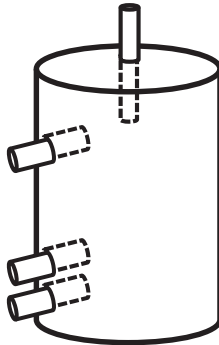

Buffer tank for space heating

Cylinder Tank Installation (For sanitary applications)

A cylinder tank must be installed in order to protect for Hot Water Module when used in sanitary applications. For Hot water module protection, always install a cylinder tank.

If the cylinder tank is not installed, the temperature of the water does not rise, or problems occurs that do not come up with warm air from the air conditioner, which is connected to the same refrigerant piping.

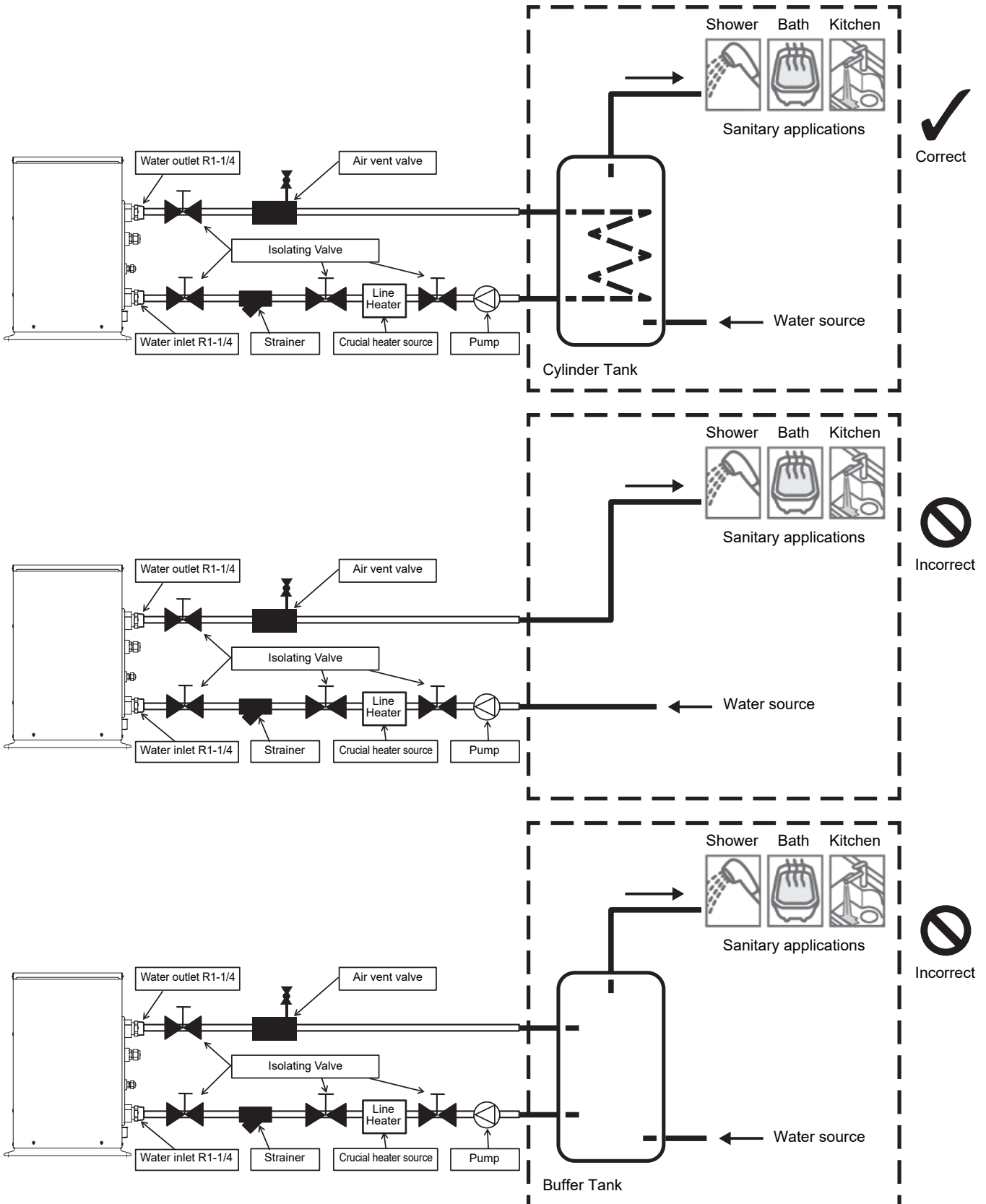

Antibacterial (For Sanitary applications)

There is no function of Antibacterial on Hot Water Module.

Heater and thermostat in local must be installed in case of use the function of antibacterial.

Shown the example following diagram.

- * Should stop operation of the Hot Water Module during antibacterial.
- In case of operating the Hot Water Module during antibacterial, there is possibility of failure on the Hot Water Module.

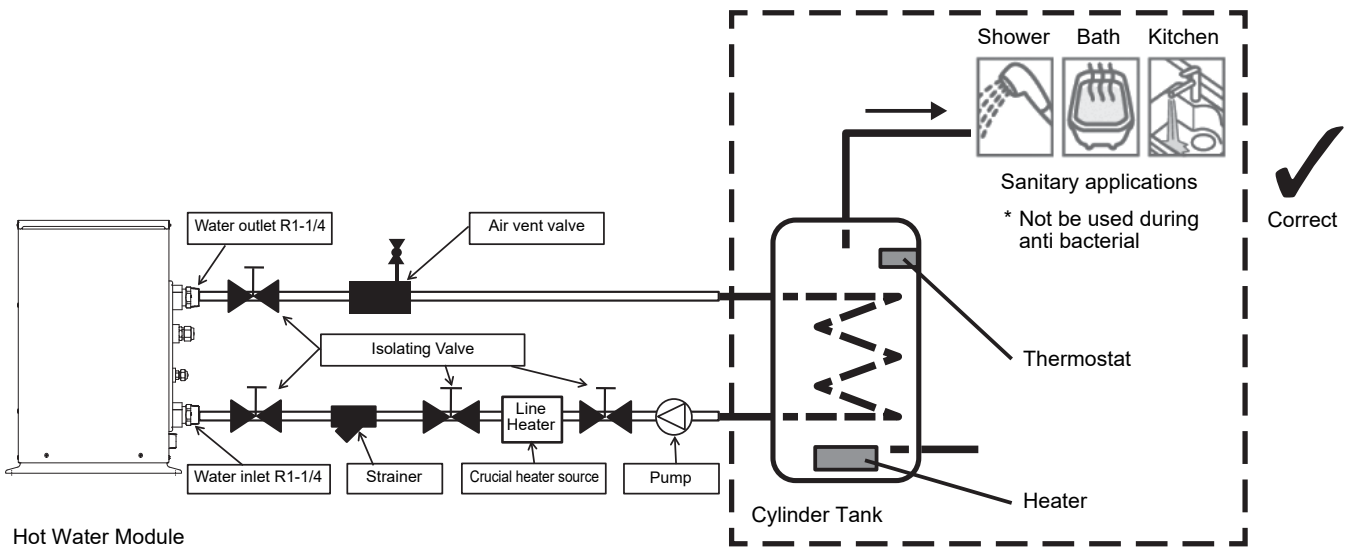

Hot Water Module

* Should be operation stop during antibacterial

External (Support) Line Heater Installations

Be sure to install a heater in the Hot Water Module.

Not installing a heater causes problems such as the HWM water heat exchanger freezing and loss of heating ability.

[1] Install the heater within 5 m of the water pipe between the Hot Water Module and the water pump, and 5 m of the HWM pipe connections.

[2] Select a heater with a capacity of 40 to 50% of the rated capacity of the HWM.

[3] To prevent fires caused by overheating, use a heater with safeguards such as a fuse and temperature type protective switch.

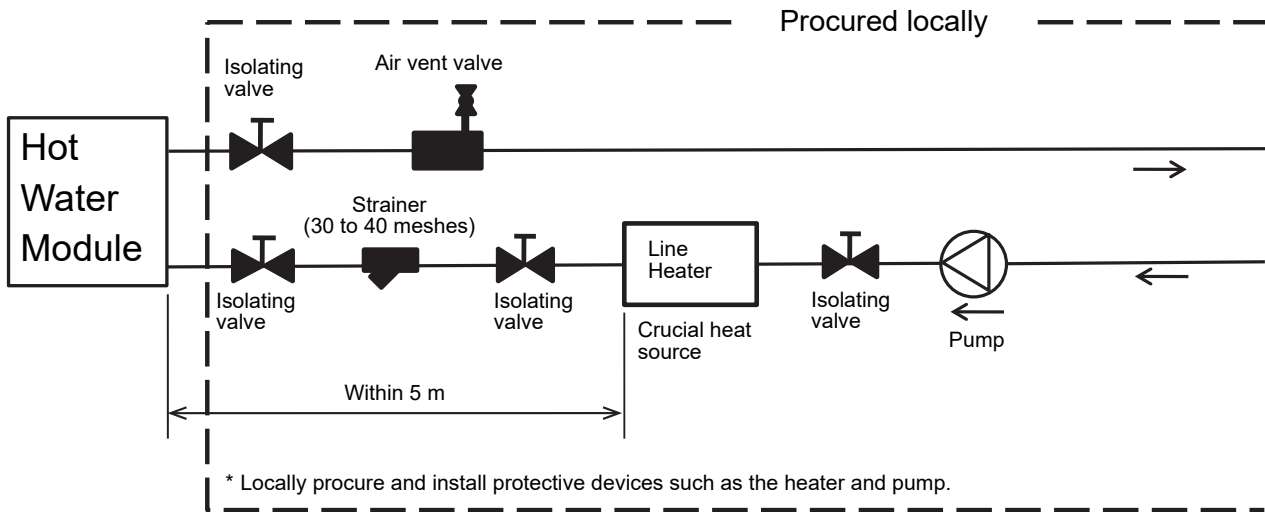

Hot Water Module Engineering Data Book

Model name:

MMW-UP_1LQ-E/TR

September, 2022

Toshiba Carrier Corporation